

INSTALLATION AND MAINTENANCE MANUAL

4XX9 SERIES PUMPS

FEATURES AND BENEFITS

- **Four Independent Pump Chambers**
 - ▶ *quiet and smooth operation*
- **Adjustable Pressure Shut-off**
 - ▶ *fine tuning for customer specific application*
- **Thermal Overload Protection**
 - ▶ *safety*
- **Self priming up to 1.8 meters (6 feet) vertical**
 - ▶ *flexible*
- **O-ring Check Valve Design**
 - ▶ *long-life and consistent performance*
- **Adjustable Bypass**
 - ▶ *eliminates need for accumulator tank*
- **Run dry capability**
 - ▶ *long-life and consistent performance*
- **CE, e1 certification approvals**
 - ▶ *compliance to EU regulations*



SPECIFICATIONS

Pump:	4 Chamber Diaphragm
Ports:	1/2"-14 NPSM-Male
Motor:	3" Diameter thermally protected
Lead wires:	16 AWG
Fuse:	See motor label for fuse
Duty Cycle:	Intermittent duty only
Control:	Adjustable by-pass and pressure switch
Approvals:	CE, e1

INSTALLATION GUIDELINES OVERVIEW

- Mount on a solid surface within 1.8 meters (6 feet) of tank
- Minimize flow restrictions in the system
- Minimize plumbing elbows and valves
- Connect flexible hose on inlet and outlet
- Affix strainer on pump inlet
- Properly sized plumbing
- No accumulator needed
- Properly sized wiring
- Proper electrical protection
- Accessible location for occasional strainer cleaning and maintenance

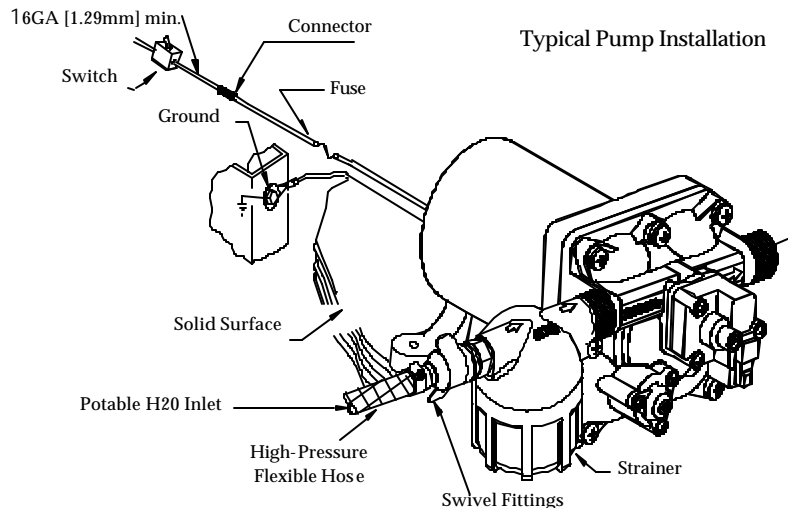

INSTALLATION GUIDELINES DETAIL

The goal of installation is quiet pump operation, achieving desired water flow, low back pressure and easy maintenance. This can be accomplished by following these guidelines:

- Mount on a **solid surface** in an **accessible location** for strainer cleaning and pump maintenance.
- Use **flexible high-pressure hose** on the pump inlet and outlet [**such as SHURflo Kit 94-591-01**].
- The pump inlet– and outlet– ports and strainer **should not** be connected to rigid plastic pipe; otherwise the normal pump action will transmit cavitation through rigid plumbing causing noise and possible loosening or cracking components.
- The pump must be installed with an adequate 50-mesh **strainer** [such as SHURflo 255 series strainers].
- Plumbing must have a minimum Inner Diameter of **13mm [1/2"]**. Smaller ID plumbing will cause cavitation, high backpressure, low flow and noise.
- Reduce restrictions on the pump inlet and outlet. This includes any shut-off valves, winterizing valves and elbows with smaller inner diameters.
- There is no requirement to use an accumulator tank with 4XX9 Series by-pass pumps.
- The pump is designed for **intermittent duty** only. Do not use these pumps for running a Reverse-Osmosis [RO] filtration system. High pressure and continuous duty usage will shorten the life of the pump and is not covered under warranty.
- Wire Size is 16 GA the **MINIMUM**, 12 GA is recommended (please **See Wire Chart** in Electrical Section for wire sizing).
- The minimum power circuit requirement is 10 Amps.
- **Reduce restrictions on the inlet and outlet.** This includes small inner diameter shut-off valves, winterizing valves and elbows.

- If the RV has an **Intellitec Pump Controller**, it must be rated at 15 or 20 amps. If the controller is rated at 7.5 Amps, either it must be replaced with a new controller or a high-amp relay must be used.

MOUNTING

- Mount the pump on a solid surface to prevent vibration and noise.
- Mount the pump within 6 feet [1.8 Meters] of the water storage tank for best performance and pump life. Although the pump can pull further, the further it pulls the harder it runs increasing vibration and noise, and reducing output and pump life.
- Mount the pump in a space of at least 1 cubic foot for adequate ventilation to prevent the electric motor overheating.
- Pump may be mounted in any orientation.
- Position the pump for easy access for cleaning strainer, maintenance and service.

PLUMBING

- Installation of a strainer prior to the pump inlet is required to prevent debris from entering the pump. If a strainer is not installed prior to the pump then the warranty is not valid.
- For noise and vibration reduction use at least 18 in. [0.5M] of ½" [13mm] I.D. flexible high-pressure hose connected to both inlet– and outlet- ports. These hose should be anchored where it meets the hard plumbing to reduce plumbing vibration. The pump ports and strainer should not be connected to rigid plastic pipe.

ELECTRICAL

- The pump works best on an individual filtered circuit, protected by the fuse or breaker specified on the pump label.
- A 15-Amp switch is recommended and should be attached to the positive lead.
- Proper wire sizing is required for good pump operation. If the wire is too small, low voltage will affect the pump performance and can create hazard.
- **SHUT OFF POWER TO THE PUMP WHEN LEAVING THE RV UNATTENDED.**

Minimum Wire Size for a 10% voltage drop on a 12VDC, 10 Amp Circuit. Length is the distance from the power source to pump and back to ground.

Feet	[Meters]	AWG [mm ²]
0-25	[0-7.6]	16 [1.3]
25-50	[7.6-15.2]	14 [2.1]
50-70	[15.2-21.3]	12 [3.3]
70-110	[21.3-33.5]	10 [5.3]

OPERATION

The 4XX9 Series pumps are designed for intermittent duty only. The pump operates normally up to its rated by-pass pressure, whereby a spring-loaded by-pass valve opens, allowing flow back from the output side to the input side, providing smooth, steady flow with virtually no cycling, all the way down to a trickle. As a faucet is opened, the pressure will drop, the by-pass will close and full flow is achieved. This allows good flow, even with today's commonly used restrictive showers and pullout sprayer faucets. Performance will vary, of course, depending on the voltage to the pump: lower voltage = lower flow, higher voltage = higher flow. Always be cautious and practice electrical safety. It is always best to shut off power to the pump when leaving the RV unattended.

ABOUT THE BY-PASS

The by-pass is a spring loaded diaphragm that, when open allows water from the discharge side back to the inlet side. For 55 psi [3.80 bar] models the by-pass is preset to begin opening at around 2.75 bar [40 psi] and full by-pass occurs at about 4.3 bar [62 psi]. Lower pressure pumps vary depending on the by-pass pressure and switch settings. The pressure switch on the pump is set to shut off at 55 psi. If the switch or by-pass are adjusted too much, the by-pass and switch shut-off can overlap and **THE PUMP WILL NOT SHUT OFF**. Screwing the switch screw in clockwise will raise the shut-off pressure. Unscrewing the switch screw counterclockwise will lower the pump shut-off pressure. Screwing the by-pass screw in will raise the pressure at which the by-pass starts and raise the full by-pass pressure. Unscrewing the by-pass screw counterclockwise will lower the pressure at which by-pass starts and lower the full by-pass pressure. **WARNING: If full by-pass is reached before the shut-off setting, the pump will not shut off.** Full by-pass pressure setting should be at least 5 psi higher than pump shut off pressure.

MAINTENANCE

Checking and cleaning the strainer, normal sanitizing and winterizing and occasional checking all plumbing hardware and fittings for tightness is all that is normally required. Lack of sanitizing is the number one reason for premature pump failure and poor performance over time. Lack of sanitizing will cause scale build-up on the diaphragm and valves, causing low flow and leak back (occasionally pump cycling with no faucets open or tank filling up when hooked up to city water).

For SANITIZING AND WINTERIZING procedure please consult the RV manufacturer.

Number	4029-181-X54	4029-181-X32	4008-131-X65	4009-101-X65	4029-181-X43	4009-101-X32	4009-101-X54	4009-131-X54	4009-101-X87
1	94-890-09	94-890-07	94-800-00	94-800-00	94-800-08	94-890-07	94-890-09	94-890-09	94-890-08
2,3	94-800-01	94-800-01	94-800-01	94-800-01	94-800-01	94-800-01	94-800-01	94-800-01	94-800-01
4	94-800-02	94-800-02	94-800-02	94-800-02	94-800-02	94-800-02	94-800-02	94-800-02	94-800-02
5 (12V)	94-11-189-05	94-11-189-05	--	94-11-302-00CE	94-11-189-05	94-11-302-00CE	94-11-302-00CE	--	94-11-302-00CE
5 (24V)	--	--	94-11-303-00	--	--	--	--	94-11-303-00	--
Check Valve (N/S)	94-800-03	94-800-03	94-800-03	94-800-03	94-800-03	94-800-03	94-800-03	94-800-03	94-800-03
1,2,3,4	94-890-04	94-890-05	94-800-04	94-800-04	94-800-10	94-890-05	94-890-04	94-890-04	94-890-06
Switch Kit (N/S)	94-890-01	94-890-00	94-800-05	94-800-05	94-800-09	94-890-00	94-890-01	94-890-01	94-890-02

REPAIR KITS

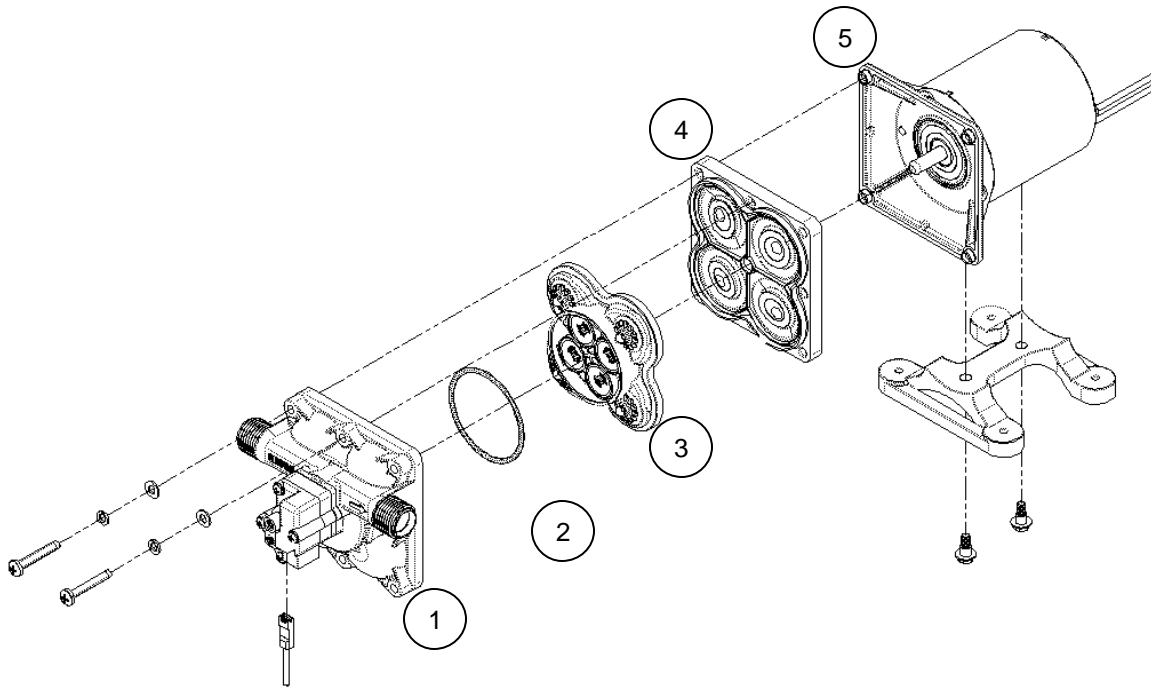

Visit our Web Site at <http://www.shurflo.com>
 Shurflo reserves the right to update specifications,
 change prices, or make substitutions without notice.

SHURflo Europe, Middle East, Africa
Pentair Water Belgium bvba
 Industriepark Wolfstee, Toekomstlann 30
 B-2200 Herentals, Belgium
 Phone +32-14-283500
 Fax +32-14-283505



SHURflo®



Pentair Water
 FLOW TECHNOLOGIES GROUP