

RV PRODUCT DATA SHEET

OEM: 4009-101-A87

AFTERMARKET: 4009-101-B87

APPLICATION

Multi-fixture RV adjustable by-pass fresh water pump installation. Other uses may include 12V DC pressurized water systems in cabins. This pump may be used for general fresh water transfer.

PUMP:

Type: 4 Chamber Diaphragm pump
 Ports: 1/2"-14 NPSM-Male.
 Liquid: 54 °C [130 °F] Max
 Dry-Prime: 1.82 M [6 feet]
 Inlet PSI: 2.1 Bar [30 PSI] Max
 Run Dry: Yes

ELECTRICAL:

Motor: 12VDC Permanent Magnet, Intermittent Duty
 Protection: Thermal Overload, Automatic Restart
 Leads: 16 AWG, 25 cm [10"] Red +, 33 cm [13"] Black -
 Fuse: 7 Amp Recommended
 Control: Shut-Off 3.1 Bar [45 PSI]
 Restart 2.06 Bar [30 PSI]
 Max By-Pass 3.4 Bar [50 PSI]

MATERIALS:

Housing: Polypro
 Valves: EPDM
 Diaphragm: Santoprene
 Hardware: Stainless and Zinc Plated Steel

APPROVALS:

CSA, CE, e-Mark

WARRANTY:

Contact SHURflo Europe for details

SHIPPING:

Net Weight: 2.3 Kg [5 Lb] each
 Carton Quantity: 12
 Carton Weight: 27 Kg [60 Lb]
 Carton Size: 60.9cm x 45.7cm x 27.9cm
 [24"L x 18"W x 11"H]

RELATED DOCUMENTS:

Catalog: MS-030-138
 Installation Manual: 911-1023
 Applications Spec Guide: MS-020-005



SHURflo's New 4009 series fresh water pump design was created with unique one-piece diaphragm and internal by-pass, assuring long life and top performance in all plumbing systems. Designed as the next legendary pump to exceed the expectations of our customers, the 4009 series pump is constructed for high flow demand, low noise and no rapid cycling. SHURflo's quality reputation has been built on the reliability and dependability of every pump we build. The 4009 series fresh water automatic demand pump is super quiet, thermally protected and can run dry without damage.

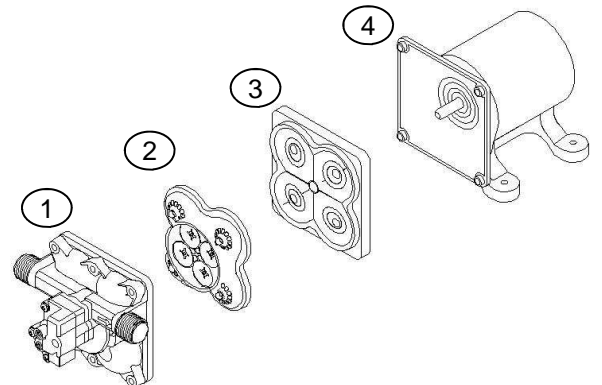

Replacement Kits

Number	Description	Part Number
*1	Upper Assy	94-890-08
2	Valve Assy	94-800-01
3	Drive Assy	94-800-02
4	Motor	94-11-302-00CE
Not Shown	Check Valve	94-800-03
1,2,3	Pump Head	94-890-06
Not Shown	Pressure Sw.	94-890-02

*Includes check valve and pressure switch

TYPICAL PERFORMANCE

PRESSURE		FLOW		CURRENT
BAR	PSI	GPM	LPM	AMPS
0.0	0	3.0	11.3	1.96
0.68	10	2.09	8.55	2.87
1.37	20	1.77	7.64	3.73
2.06	30	1.47	6.96	4.57
2.75	40	0.68	6.28	5.22

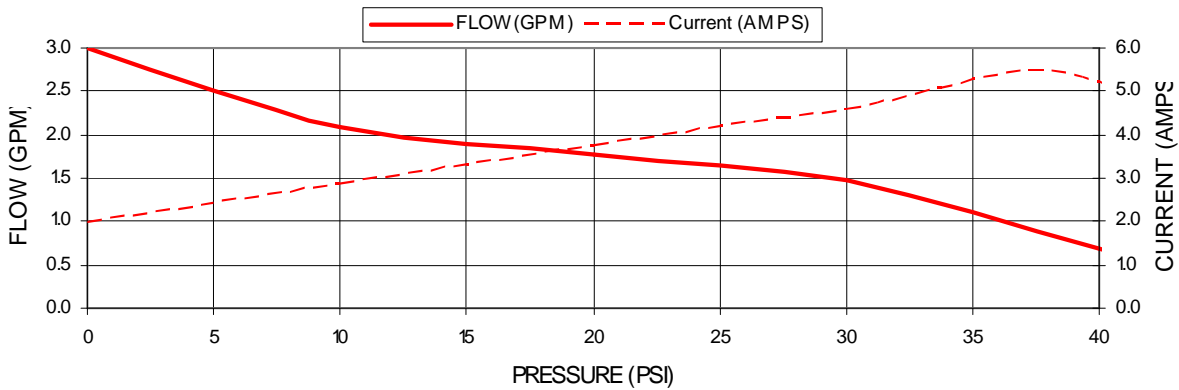

DIMENSIONS [mm]

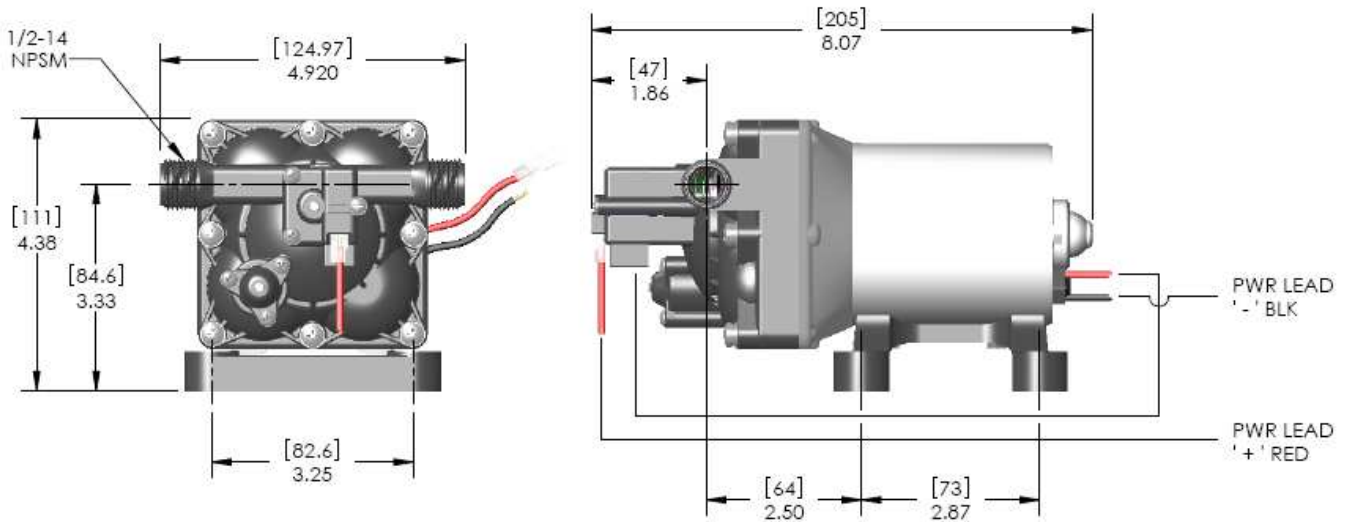

SHURFLO

3545 Harbor Gateway South, Ste. 103, Costa Mesa, CA 92626, (800) 854-3218 www.shurflo.com

SHURFLO Europe, Middle East, Africa

Pentair Water Belgium bvba, Industriepark Wolfstee, Toekomstlaan 30, B-2200 Herentals, Belgium, +32-14-283500

All Pentair trademarks and logos are owned by Pentair, Inc. All other brand or product names are trademarks or registered marks of their respective owners. Because we are continuously improving our products and services, Pentair reserves the right to change specifications without prior notice. Pentair is an equal opportunity employer.

4009-101-A87 (B87) Rev. 07/12 ©Pentair, Inc. All rights Reserved.