

# DE'LONGHI

## COOKING

---

**INSTALLATION and SERVICE INSTRUCTIONS  
USE and CARE INSTRUCTIONS**

**DE 302 IB-1  
INDUCTION BUILT-IN COOKTOPS**

distributed by  
**DeLonghi Australia Pty Ltd**  
**DeLonghi New Zealand Ltd**



## **Dear Customer,**

*Thank you for having purchased and given your preference to our product.*

*The safety precautions and recommendations reported below are for your own safety and that of others. They will also provide a means by which to make full use of the features offered by your appliance.*

*Please keep this booklet in a safe place. It may be useful in future, either to yourself or to others in the event that doubts should arise relating to its operation.*

***This appliance must be used only for the task it has explicitly been designed for, that is for cooking foodstuffs. Any other form of usage is to be considered as inappropriate and therefore dangerous.***

***The manufacturer declines all responsibility in the event of damage caused by improper, incorrect or illogical use of the appliance or be faulty installation.***

This appliance has been designed and constructed in accordance with the following codes and specifications:

AS/NZS 60335.1      General Requirements for Domestic electrical appliances  
AS/NZS 60335.2.6    Particular Requirements for Domestic electrical cooking appliances  
AS/NZS CISPR 14.1   Electromagnetic Compatibility Requirements.

### **PRODUCT LABEL**



## IMPORTANT SAFETY PRECAUTIONS AND RECOMMENDATIONS

**IMPORTANT: This appliance is designed and manufactured solely for the cooking of domestic (household) food and is not suitable for any non domestic application and therefore should not be used in a commercial environment.**

**The appliance guarantee will be void if the appliance is used within a non domestic environment i.e. a semi commercial, commercial or communal environment.**

**Read the instructions carefully before installing and using the appliance.**

- After having unpacked the appliance, check to ensure that it is not damaged.  
In case of doubt, do not use it and consult your supplier or a professionally qualified technician.
- Packing elements (i.e. plastic bags, polystyrene foam, nails, packing straps, etc.) should not be left around within easy reach of children, as these may cause serious injuries.
- Some appliances are supplied with a protective film on steel and aluminium parts. **This film must be removed before using the appliance.**
- **IMPORTANT:** The use of suitable protective clothing/gloves is recommended when handling or cleaning this appliance.
- Do not attempt to modify the technical characteristics of the appliance as this may become dangerous to use. The manufacturer declines all responsibility for any inconvenience resulting from the inobservance of this condition.
- Do not operate your appliance by means of an external timer or separate remote-control system.
- Do not carry out cleaning or maintenance operations on the appliance without having previously disconnected it from the electric power supply.
- Do not use a steam cleaner because the moisture can get into the appliance thus make it unsafe.
- Do not touch the appliance with wet or damp hands (or feet).
- Do not use the appliance whilst in barefoot.

- If you should decide not to use this appliance any longer (or decide to substitute another model), before disposing of it, it is recommended that it be made inoperative in an appropriate manner in accordance to health and environmental protection regulations, ensuring in particular that all potentially hazardous parts be made harmless, especially in relation to children who could play with unused appliances.
- The various components of the appliance are recyclable. Dispose of them in accordance with the regulations in force in your country. If the appliance is to be scrapped, remove the power cord.
- After use, ensure that the controls are in the off position.
- Children less than 8 years of age shall be kept away unless continuously supervised.
- This appliance can be used by children aged from 8 years and above and persons with reduced physical, sensory or mental capabilities or lack of experience and knowledge if they have been given supervision or instruction concerning use of the appliance in a safe way and understand the hazards involved. Children shall not play with the appliance. Cleaning and user maintenance shall not be made by children without supervision.
- The manufacturer declines all liability for injury to persons or damage to property caused by incorrect or improper use of the appliance.
- **WARNING:** During use the appliance and its accessible parts become hot; they remain hot for some time after use.
  - Care should be taken to avoid touching heating elements on the hob.
  - To avoid burns and scalds, young children should be kept away.
- Make sure that electrical cables connecting other appliances in the proximity of the cooktop cannot come into contact with the hob.
- **WARNING:** Unattended cooking on a hob with fat or oil can be dangerous and may result in fire. NEVER try to extinguish a fire with water, but switch off the appliance and then cover flame e.g. with a lid or a fire blanket.
- **WARNING:** Danger of fire: do not store items on the cooking surfaces.
- Do not place or leave empty pans on the glass ceramic hob.
- Do not allow heavy or sharp objects to drop on the glass ceramic hob.

- Do not scratch the hob with sharp objects. Don't use the hob as a work surface.
- **WARNING:** If the hob is cracked or otherwise damaged by falling objects etc., disconnect the appliance from the electrical power supply to avoid the possibility of electric shock and call Customer Service.
- **WARNING:** When correctly installed, your product meets all safety requirements laid down for this type of product category. However special care should be taken around the underneath of the appliance as this area is not designed or intended to be touched and may contain sharp or rough edges, that may cause injury.
- **INDUCTION HOBBS:**
  - Metallic objects such as knives, forks, spoons and lids should not be placed on the hob surface since they can get hot.
  - Do not use metallic kitchen utensils (e.g. ladles). It is preferable to use plastic or wood kitchen utensils.
  - Please use pans of recommended size (see minimum pan diameter recommended). It is not advisable to use pans smaller than the cooking zone. The pans have to be placed in the centre of the cooking zone.
  - Do not use defective pans or pans with a curved bottom.
  - Please use suitable pans marked for induction cooking.
  - Please keep your distance from the electromagnetic fields by standing 5-10 cm from the cooking zones. When possible use the rear cooking zones.
  - Magnetic objects (e.g. credit cards, floppy disks, memory cards) and electronic instruments (e.g. computers) should not be placed near the induction hob.
  - The heating of magnetic tins is forbidden! Close tins may explode by exceeding pressure while heating. There is a burning risk with open tins as well, because the integrated temperature protection can't work well.
  - **IMPORTANT WARNING:** The induction hob complies with European Standards for domestic cooking appliances. Therefore it should not interfere with other electronic units. Persons with cardiac pacemakers or any other electrical implants must check with their doctor if they can use an induction cooking system (and check any possible interferences with the implants).

# INSTALLATION

## CAUTION:

- This appliance must be installed in accordance with these installation instructions.
- This appliance shall only be serviced by authorised personnel.
- This appliance is to be installed only by an authorised person in compliance with the current electrical regulations and in observation of the instructions supplied by the manufacturer.  
Failure to comply with this condition will render the guarantee invalid.
- Incorrect installation, for which the manufacturer accepts no responsibility, may cause personal injury or damage.
- Always disconnect the appliance from mains power supply before carrying out any maintenance operations or repairs.

## FITTING REQUIREMENTS

This cooktop can be built into a working surface 30 to 40 mm thick and 600 mm deep. In order to install the ceramic hob into the kitchen fixture, a hole with the dimensions shown in figure 1 has to be made, keeping in consideration the following:

- The cooktop shall not be installed directly above a dishwasher, fridge, freezer, washing machine or clothes dryer, as the humidity may damage the cooktop electronics.
- If the cooktop is installed above an oven, the oven shall be provided with cooling fan. The two appliances should be connected to the electrical supply with independent connections.
- **IMPORTANT WARNING! This cooktop requires adequate supply of fresh, cool air to fully function. The base of the cooktop must have direct unrestricted ventilation to the room where the cooktop is installed. Follow the requirements of figure 3 or 4.**
- There must be a distance of at least 650 mm between the hob and any wall cupboard or extractor hood positioned immediately above (see fig. 2).
- **We would point out that the adhesive which bonds the plastic laminate to the furniture must withstand temperatures not less than 150° C to avoid delamination.**
- **The walls of the units must be capable of resisting temperatures of 75 °C above room temperature.**
- **Do not seal the cooktop into the benchtop with silicone or glue; this makes future servicing difficult. Delonghi will not cover the costs of removing the cooktop, or of damage caused by this removal.**
- **The walls surrounding the cooktop must be made of heat-resistant material.**
- **Do not install the appliance near inflammable materials (eg. curtains).**

## WARNING

When correctly installed, your product meets all safety requirements laid down for this type of product category. However special care should be taken around the underneath of the appliance as this area is not designed or intended to be touched and may contain sharp or rough edges, that may cause injury.

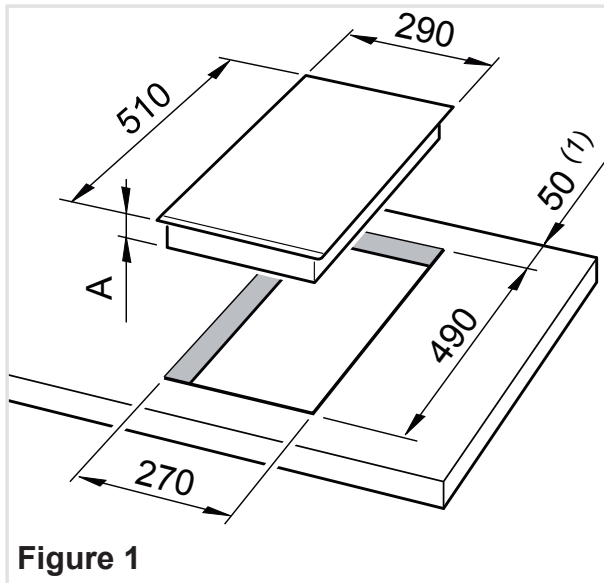

A	68 mm	from the top of countertop to bottom of cooktop
---	-------	---

- (1) at least 50 mm between the back side of the cut-out and the back of the countertop.

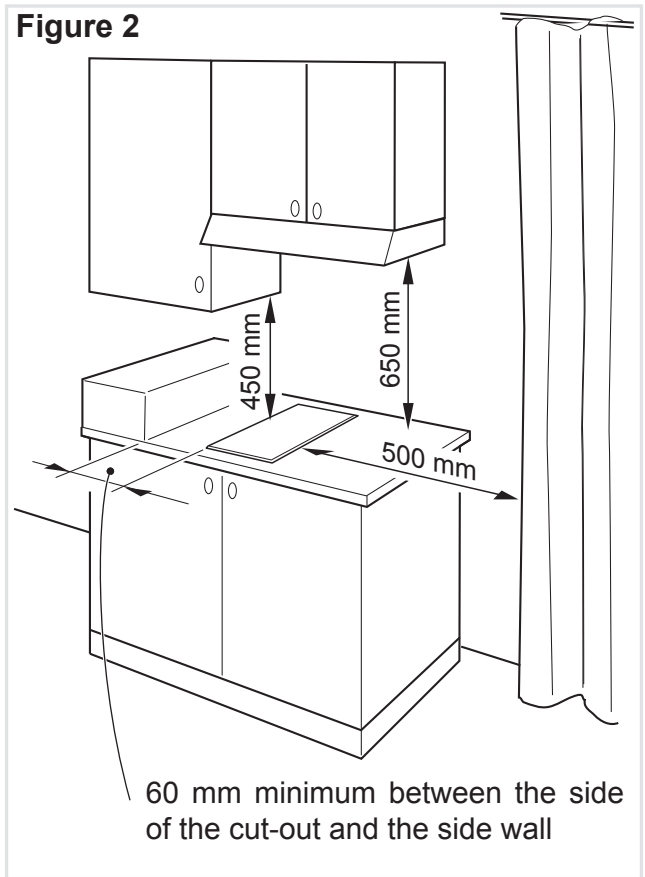

**Figure 3**

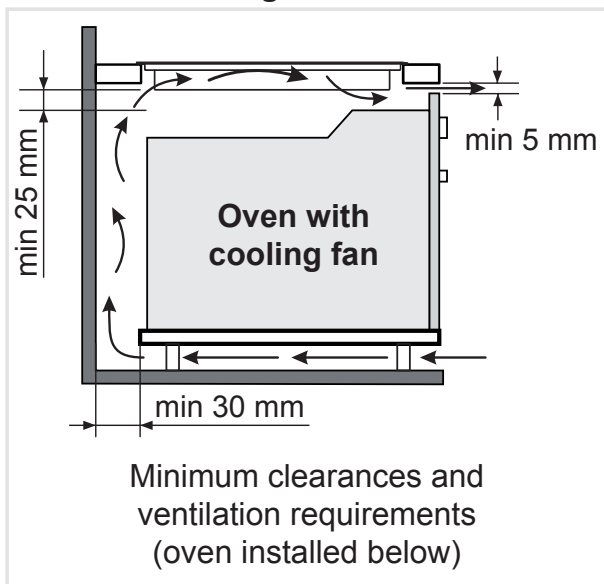

**Figure 4**

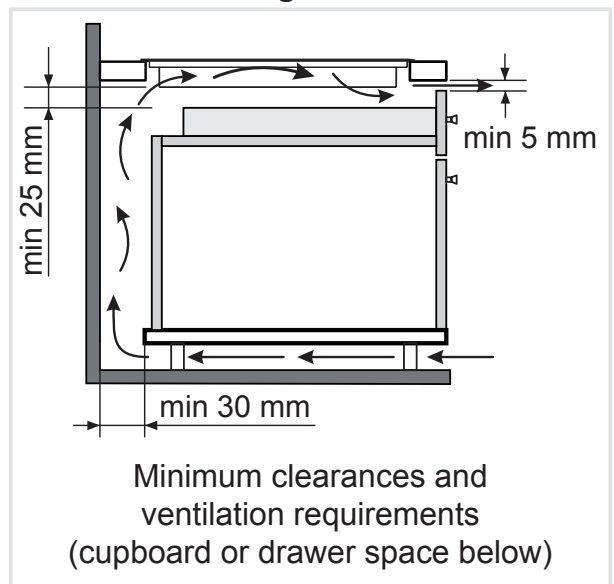

## FASTENING THE COOKTOP

Each cooktop is provided with an installation kit including brackets and screws for fastening the cooktop to benches from 30 to 40 mm thick.

The kit includes four “F” brackets and four self-threading screws “S” (fig. 6).

- Cut the unit according to the dimensions in fig. 1.
- Turn the hob upside down and rest the glass side on a soft surface.
- Spread the seal “G” around the edge of the hob (fig. 5).
- Fasten the brackets “F” to the appropriate socket holes, without tightening the screws “S” for the moment. Make sure that the tabs are mounted correctly, as shown. Rotate the tabs so that the cooktop can be put into the cutout.
- Put the cooktop into the cutout and position it correctly.
- Put the brackets “F” into place; tooth “A” of the brackets should go into the hole (fig. 6).
- Tighten screws “S” until the cooktop is completely secured to the bench.
- Using a sharp cutter or trimmer knife, trim the excess sealing material around the edge of the cooktop. Take care not to damage the workbench.

Figure 5

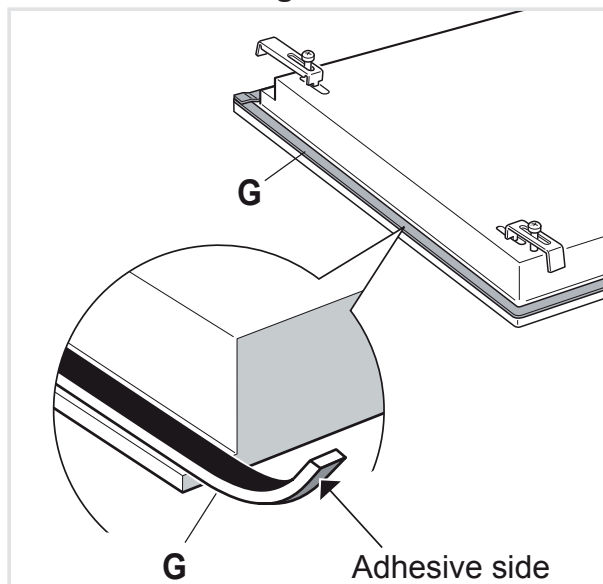
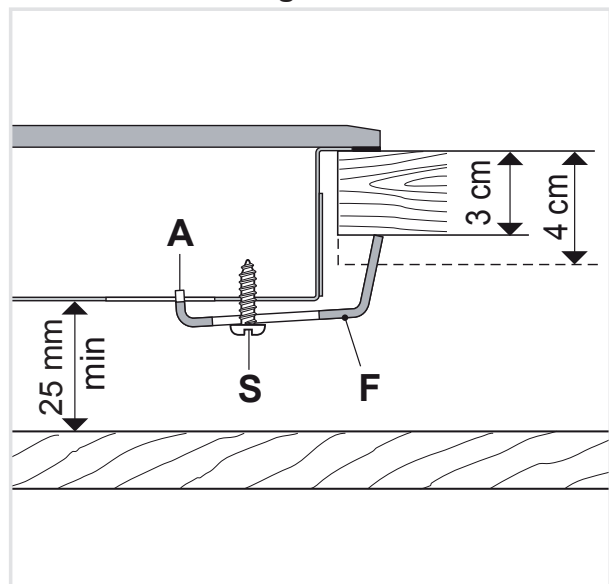

Figure 6





## ELECTRICAL REQUIREMENTS

- The appliance must be connected to the mains checking that the voltage corresponds to the value given in the rating plate and that the electrical cable sections can withstand the load specified on the plate.
- A suitable isolating switch providing full disconnection from the mains power supply shall be incorporated in the permanent wiring, mounted and positioned to comply with the local wiring rules and regulations. The isolating switch must be of an approved type and provide a 3 mm air gap contact separation in all poles (or in all active [phase] conductors if the local wiring rules allow for this variation of the requirements).
- The isolating switch shall be easily accessible to the customer with the cooktop installed.
- The power supply cable must not touch the hot parts and must be positioned so that it does not exceed 75°C above ambient.
- To connect the appliance to the mains electricity supply, do not use adapters, reducers or branching devices as they can cause overheating and burning.

### **N.B. The connection of the appliance to earth is mandatory.**

If the installation requires alterations to the domestic electrical system call a qualified electrician. He should also check that the domestic electrical system is suitable for the power drawn by the appliance.

**Replacing the power cord (not supplied with the appliance) must be done by a qualified electrician in accordance with the instructions supplied by the manufacturer and in compliance with established electrical regulations.**

## CONNECTION OF THE POWER SUPPLY CABLE

**Important! This cooktop must be connected to the electricity supply only by an authorised person.**

To connect the feeder cable to the hob it is necessary to carry out the following operations:

- Turn the cooktop over and unhook the terminal board cover by inserting a screwdriver into the two hooks “**A**” (fig. 7).
- Open the cable gland by unscrewing screw “**F**” (fig. 8), unscrew the terminal screws.
- The supply cable, of suitable type and section, is connected to the terminal board following the diagram in fig. 9.

## VOLTAGE AND POWER CONSUMPTION

220-240 V    50/60 Hz    3700 W    16.08 A

## FEEDER CABLE SECTION

This hob must be connected to electrical supply using V105 insulated cable.

220-240 V ac                      3 x 2,5 mm<sup>2</sup> (\*)

(\*) Connection with wall box connection

If the supply cord (not supplied with the appliance) is damaged, it must be replaced by the manufacturer or its service agent or a similarly qualified person in order to avoid a hazard.

Figure 7

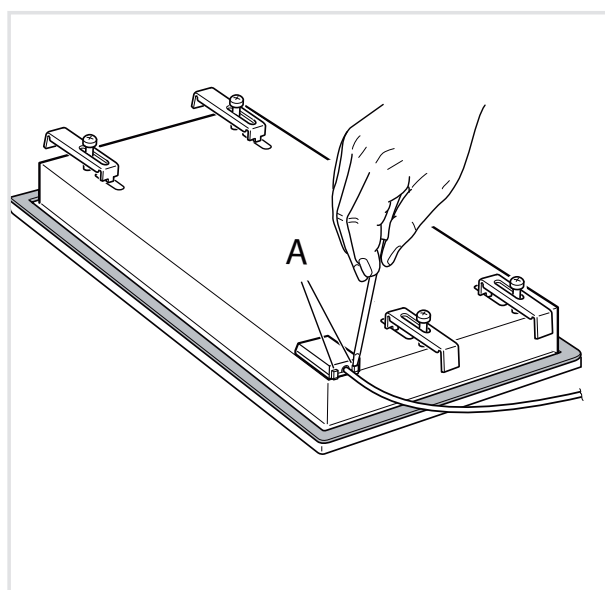

Figure 8

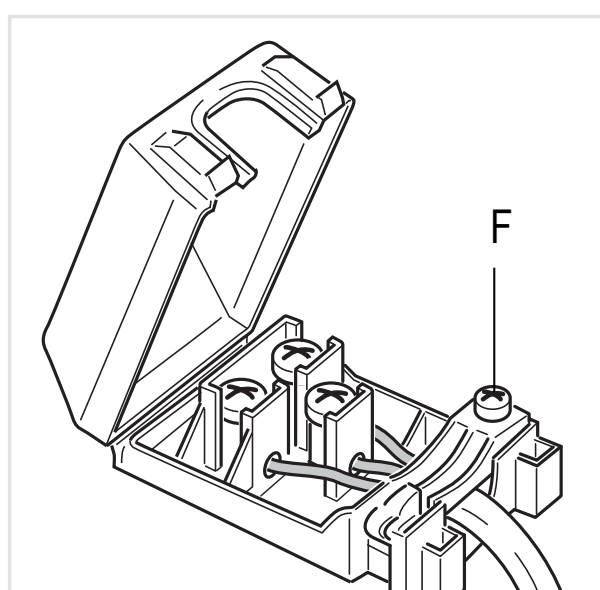
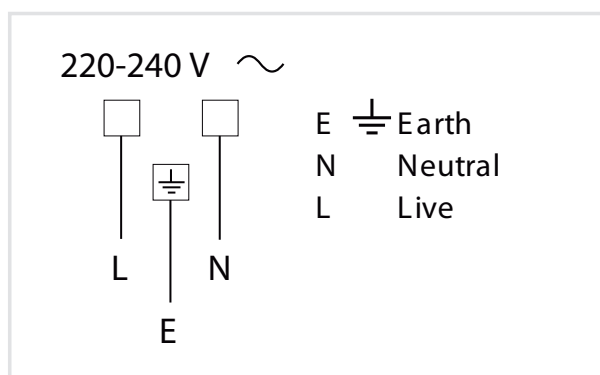
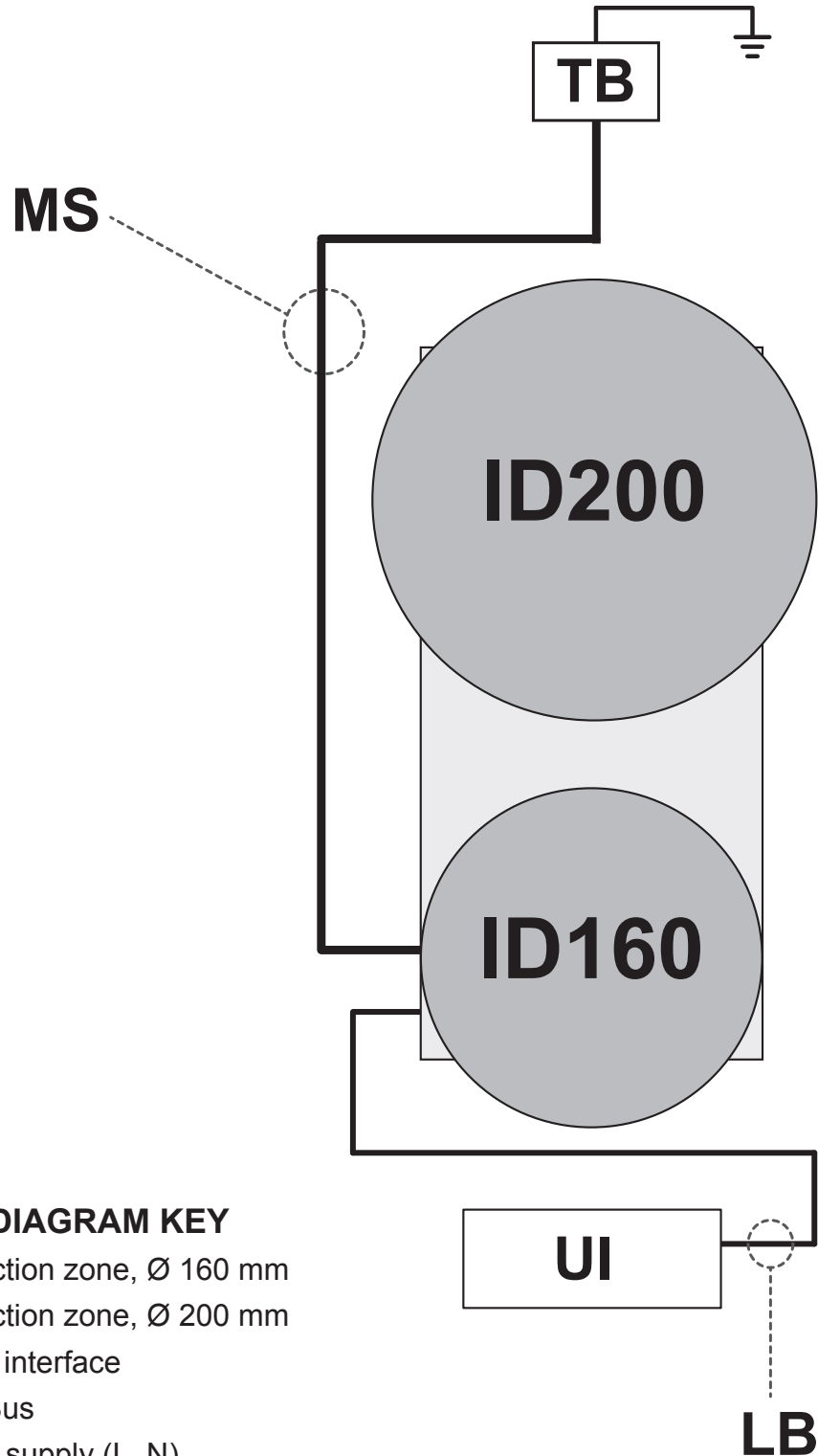

Figure 9



# ELECTRIC DIAGRAMS

Figure 10



## ELECTRIC DIAGRAM KEY

- ID160** Induction zone, Ø 160 mm
- ID200** Induction zone, Ø 200 mm
- UI** User interface
- LB** Lin-Bus
- MS** Main supply (L, N)
- TB** Terminal block

# USE AND CARE

## FEATURES AND TECHNICAL DATA

Figure 11

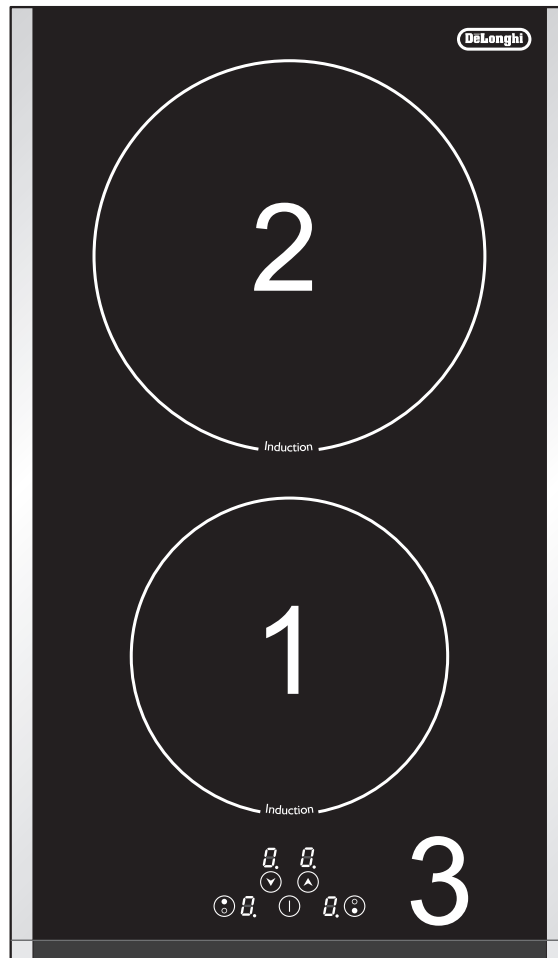

- |                           |          |   |
|---------------------------|----------|---|
| 1. Induction cooking zone | Ø 160 mm | Normal Power: 1200 W<br>Booster Power: 1400 W |
| 2. Induction cooking zone | Ø 200 mm | Normal Power: 2300 W<br>Booster Power: 3000 W |
| 3. Touch controls         |          |   |

Note: The Nominal and Booster Power may change depending on the size and material of the pan set on the cooking zone.

Figure 12

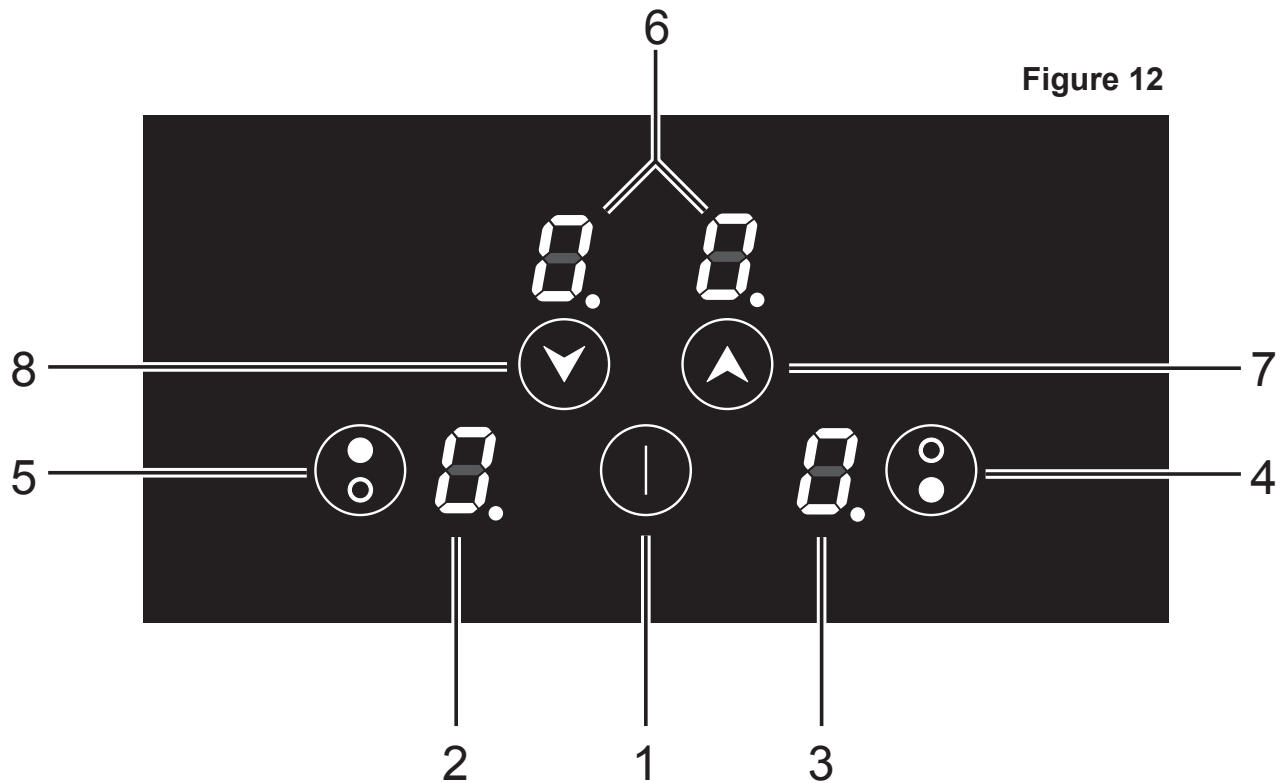

## TOUCH CONTROLS

1. ON/OFF key
2. Rear cooking zone display
3. Front cooking zone display
4. Front cooking zone selector key
5. Rear cooking zone selector key
6. Automatic cooking (timer) display
7. Increasing key (power or timer)
8. Decreasing key (power or timer)

### Notes:

- Each selection (by touching one of the keys) is indicated by an acoustic signal (beep).
- The touch control area is switched off automatically (and a warning beep sounds):
  - if one or more keys are touched for more than 10 seconds;

**Attention:** Detach the appliance from the mains if the ceramic glass is cracked and contact the After-Sales Service. Metallic objects such as knives, forks, spoons and lids should not be placed on the hob surface since they can get hot.

# HOW TO USE THE COOKING HOB

The ceramic hob is fitted with induction cooking zones. These zones, shown by painted disks on the ceramic surface, are controlled by a touch control system.

In the front central area of the hob, the displays of the touch control system indicate:

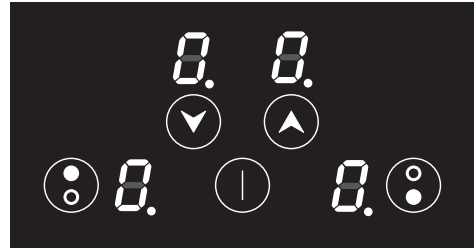

Figure 13



= Cooking zone Off (not activated)



= Cooking zone On (activated but not operating).

If all the zones are in zero setting, the touch control system switches off automatically (touch controls Off) after about 10 seconds.



= Power levels



= "Booster" function



= Remaining heat indicator



= Pan detection indicator



= Child Lock safety

Note: Each lit figure (excluding the "Automatic cooking timer" display) refers to the relevant cooking zone.

## INDUCTION COOKING SYSTEM

When your induction hob is switched On and a cooking zone has been selected, the electronic circuits produce induced currents that instantaneously heat the bottom of the pan which then transfers this heat to the food. Cooking takes place with hardly any energy loss between the induction hob and the food.

Your induction hob operates only if a correct pan with the right features is placed on a cooking zone. Please refer to COOKWARE FOR INDUCTION COOKING.

If the pan detection symbol  appears on the display, your pan is not suitable and your induction hob will not operate. After 10 minutes without detecting any pan, the cooking zone switches Off automatically.

## REMAINING HEAT INDICATORS

When the temperature of a cooking zone is still hot, the relevant  remaining heat indicator lights up on the display to alert you of the hot surface.

Avoid touching the hob surface over the cooking area. Please pay special attention to children.

When the  is lit on the display, it is still possible to start cooking again; just operate the cooking zone as indicated in the chapter POWER IGNITION AND ADJUSTMENT OF A COOKING ZONE.

## COOKWARE FOR INDUCTION COOKING

The induction cooking system OPERATES ONLY if using correct cookware suitable for induction cooking.

The bottom of the pan has to be ferromagnetic to generate the electromagnetic field necessary for the heating process (meaning a magnet has to stick to the bottom of the pan).

Pans made from the following materials are not suitable:

- glass, wood, porcelain, ceramic, stoneware;
- pure stainless steel, aluminium or copper without magnetic bottom.

To check if a pan is suitable or not:

- test the bottom of the pan with a magnet: if the magnet sticks, the pan is suitable.
- if a magnet is not available pour a small amount of water inside the pan and place the pan on a cooking zone. Switch on the cooking zone: if the symbol  (pan detection) appears on the cooking zone display (instead of the power level), the pan is not suitable.

**Important note:** the cooking zones will not operate if the pan diameter is too small (  pan detection symbol will appear on the cooking zone display). To correctly use the cooking zones follow the indications given in the following table.

Induction cooking zone	Minimum pan diameter recommended (referred to the bottom of the pan)
Cooking zone Ø 160 mm	110 mm
Cooking zone Ø 200 mm	145 mm

**Pay attention:** The pan shall always be centred over the middle of the cooking zone. It is possible to use oversized pans but the bottom of the pan cannot touch other cooking zones.

Always use pans with thick, completely flat bottom.

Do not use pans with concave or convex bottom; these could cause overheating of the cooking zone.

**Note:** Some types of pans could cause noise when used on an induction cooking zone. The noise does not mean any failure on the appliance and does not influence the cooking operation.

## HOW TO SWITCH ON/OFF THE COOKTOP

### Switching ON

Touch the key  until the touch control system is lit (fig. 14). The displays of the cooking zones read “0”.

#### Notes:

- If the safety Child Lock protection is active, the cooktop can be used only after having deactivated this protection (see chapter CHILD LOCK SAFETY).
- Auto switch-Off: If a cooking zone is not turned On within 15 seconds, the cooktop will automatically switch off.

Figure 14

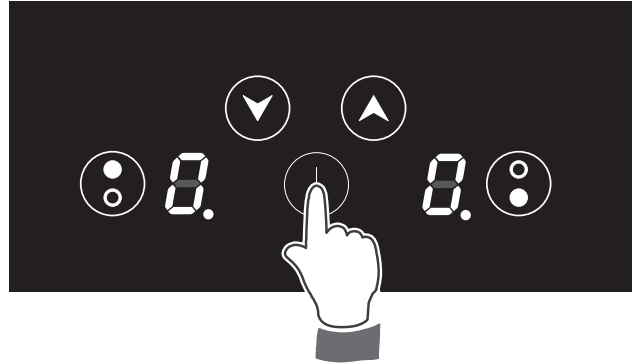

### Switching OFF

The cooktop may be switched Off at any time by pressing the key . If any cooking zones are turned On, they will be turned Off.

## POWER IGNITION AND ADJUSTMENT OF A COOKING ZONE

To turn On a cooking zone the cooktop must be switched On (see section “HOW TO SWITCH ON/OFF THE COOKTOP”).



- Select a cooking zone by touching the relevant key of the cooking zone to be used (fig. 15).
- Press the key  and keep it pressed until the desired power level, ranging between 1 and 9 is set. As an alternative, press the key . The choice starts from level (maximum level) down to (minimum level).
- To reset the power level press the key  and keep it pressed until power level zero (0) .
- The cooking zone display shows the selected level.
- The power level can be modified at any time.

Figure 15

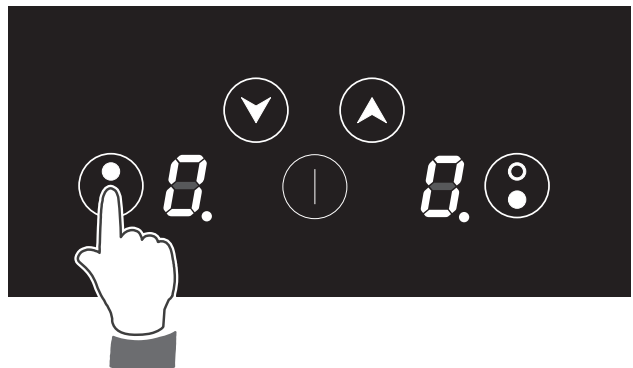
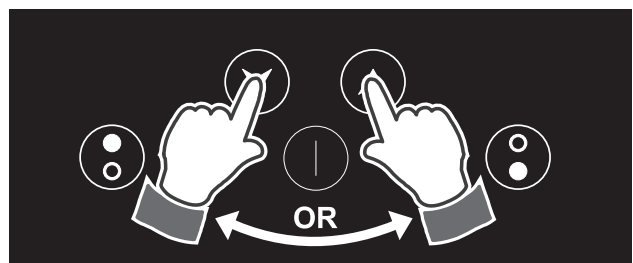

Figure 16





## BOOSTER FUNCTION

This function allows the cooking zone to operate at the “Booster” maximum power (above the nominal power) for maximum 5 minutes; it could be used, for example, to rapidly heat up large amount of water.

- **The “Booster” function is always limited to a maximum of 5 minutes.**

To activate the “Booster” function:

- Set the power level “**9**” on the selected cooking zone, then just touch the key  until the relevant display shows “**P**” (fig. 17).
- At the end of the “Booster” program (5 minutes) the cooking zone is automatically set to the power level “**9**”.
- Note: if a cooking zone is still hot, it is not possible to use the “Booster” function and “**P**” will flash if you try to activate. The cooking zone is automatically set to the maximum power level (“**9**”).

To deactivate the “Booster” function:

- Set a different power level on the selected cooking zone.  
or
- Switch Off the cooktop.

### IMPORTANT NOTES:

- **The “Booster” function is not suitable for use with non water based cooking.**
- **Do not use this function for heating oil (e.g. deep fat frying).**

Figure 17



## OPERATION TIME LIMIT OF THE COOKING ZONES

Each cooking zone is automatically switched Off after a maximum preset time if no operation is performed.

The maximum preset time limit depends on the set power level, as illustrated in this schedule.

Each operation on the cooking hob by using the touch controls will reset the maximum operation time at its initial value.

POWER LEVEL OF COOKING ZONES	OPERATION TIME LIMIT
1	480 minutes
2	360 minutes
3	300 minutes
4	300 minutes
5	240 minutes
6	90 minutes
7	90 minutes
8	90 minutes
9	90 minutes
0	5 minutes

COOKING ZONE POWER LEVEL	COOKING ZONE Ø 160 mm (Watt power)	COOKING ZONE Ø 200 mm (Watt power)
1	36	70
2	60	120
3	100	180
4	140	276
5	215	420
6	336	645
7	500	960
8	770	1470
9	1200	2300
P	1400	3000

**Measured Peak Power Levels**  
(Note: the cooker pulses to achieve an average level)

	730
440	860
	1100
720	1250
880	1250
880	1250
880	1520



**EXAMPLES OF COOKING POWER SETTING**

0	Cooking zone not operating	
1 to 2	Melting Reheating	Sauces, butter, chocolate, gelatine Dishes prepared beforehand
2 to 3	Simmering Defrosting	Rice, pudding, sugar syrup Dried vegetables, fish, frozen products
3 to 4	Steam	Vegetables, fish, meat
4 to 5	Water	Steamed potatoes, soups, pasta, fresh vegetables
6 to 7	Medium cooking Simmering	Meat, lever, eggs, sausages Goulash, roulade, tripe
7 to 8	Cooking	Potatoes, fritters, wafers
9	Frying, roasting Boiling water	Steaks, omelettes, fried dishes Water
P	Rapidly heat up large amount of water	

## PROGRAM FOR AUTOMATIC SWITCHING OFF OF A COOKING ZONE

This function permits to set a timer from “1” to “99” minutes for automatic turning Off the cooking zone/s.

With the cooktop switched On:

- Select the cooking zone and set the desired power level.
- Within 8 seconds, touch the timer keys  and  (the led indicating the programmed zone starts blinking) and set the timer:

By pressing the key  the initial value is “0”.

By pressing the key  the initial value is “30”.

- The time can be changed at any time following the same procedure here above indicated (selecting previously the cooking zone).
- To program another cooking zone, repeat as described above.  
NOTE: The led indicating the cooking zone closest to the end of the program, is blinking. In the case of one programmed zone only, the led is blinking.

Now the program for automatic switching Off is complete.

At the end of the countdown the cooking zone will switch Off automatically, an acoustic signal (beep) will sound (for 2 minute only), “00” will flash on the timer display and the led next to the heater display will blink.

The program for automatic switch Off can be cancelled at any time:



- by resetting the timer to “00”.
- by pressing the  and  keys at the same time.
- IMPORTANT: Remember to switch Off the zone manually.

Figure 18

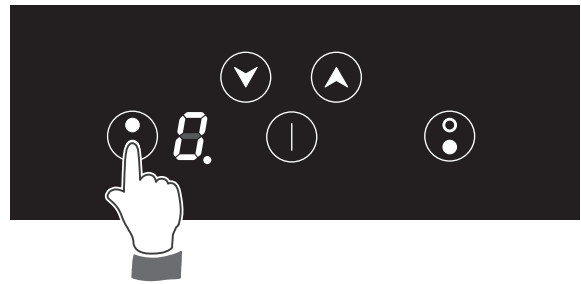

Figure 19

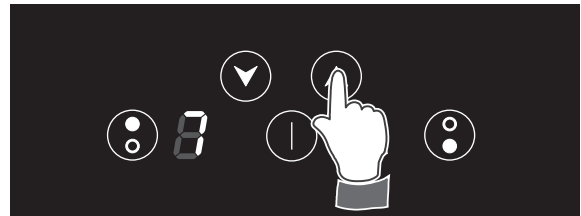

Figure 20

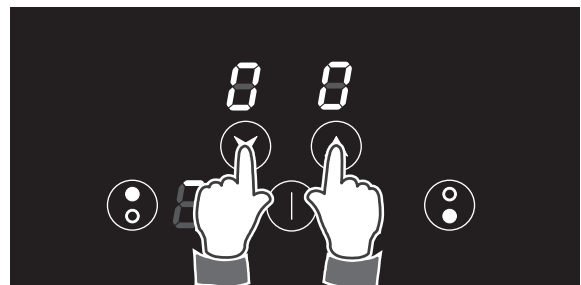
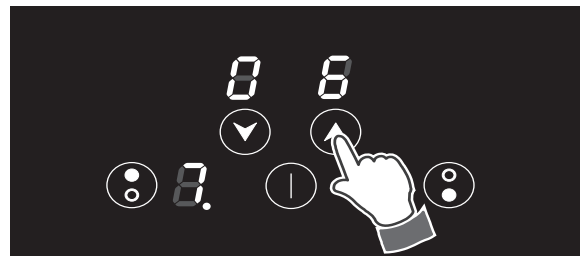





Figure 21



## CHILD LOCK SAFETY

When not using the induction hob, set the Child Lock safety to prevent children from accidentally switching On the cooking zones.

- Ensure all cooking zones are switched Off.
- If the cooktop is switched off, touch the key  until the touch control system is lit.
- Simultaneously touch the front cooking zone selector key and the key ; then touch again the same cooking zone selector key until “L” lights up.
- To deactivate the Child Lock, touch simultaneously the front cooking zone selector key and the key ; then touch again the key  until “0” lights up on the displays of the cooking zones.

### Temporary deactivation of the Child Lock



- If the cooktop is switched off, touch the key  until the touch control system is lit.
- Touch simultaneously the front cooking zone selector key and the key . Then, the product can be used until the touch control system is on; this means that the Child Lock is automatically reactivated when switching off the appliance.

Figure 22



## MAXIMUM USABLE POWER FOR THE COOKING ZONES

The power board manages a maximum total power of 3700 W.

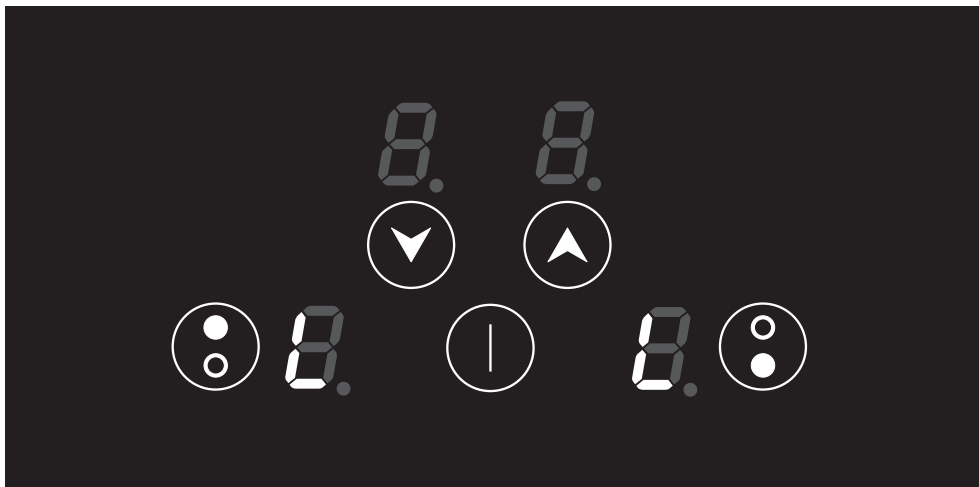
Should the cooking zones require more than 3700 W, the last selected power level has priority and the power of the other cooking zone is automatically reduced to the remaining power available.

If this occurs, the cooking zone will display a flashing figure for about 3 seconds before automatically displaying the new power level.

This means for example that:

- When setting a “Booster” programme for the second zone, the setting for the other zone could be reduced to the remaining power available.
- When setting a “Booster” programme for a zone and then another setting on the second zone, if the total power exceed 3700 W the “Booster” programme is deleted and the power reduced to the maximum power available.



## THERMAL PROTECTIONS

The induction hob is fitted with safety devices to protect the electronic system and to protect each cooking zone from overheating.

In case of overheating, one of the following automatic functions could be started by the electronic system:

- “Booster” program deleted and power reduced.
- One or more cooking zone switched Off.
- Cooling fan motor of the induction unit switched On.

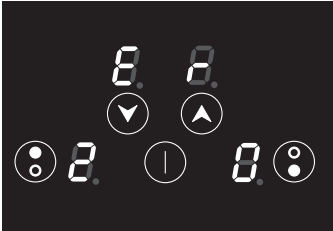
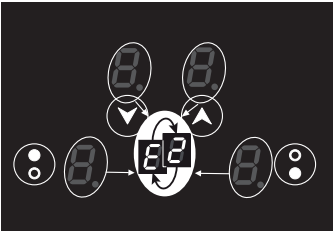
## ERROR CODES ON THE DISPLAYS OF THE COOKING ZONES

Error code	Example	What to do
<p>Erxx or Ex (not E2 or EH)</p> <p>or</p> <p>display not operative</p>		<ol style="list-style-type: none"> <li>1. Switch Off the cooktop and disconnect it from the mains.</li> <li>2. Wait for about 1 minute, then reconnect the cooktop and turn on the cooking zones.</li> <li>3. Wait for about 1 minute and if the error message does not appear again the cooking zones can be used.</li> <li>4. If the error message does not disappear repeat step from 1 to 3.</li> <li>5. If the problem continues do not use the induction hob and contact your Authorised Service Centre.</li> </ol>
<p>E2 or EH</p>		<p><b>E and 2 or E and H</b> alternating for one or more cooking zones. This indicates an overheating of the cooking zone/s.</p> <ol style="list-style-type: none"> <li>1. Switch Off the cooking zone/s and leave to cool.</li> <li>2. If the problem continues do not use the induction hob and contact your Authorised Service Centre.</li> </ol>
<p>E6 or display not operative</p>		<p>The cooktop has been incorrectly connected. The appliance shall be connected to the appropriate power supply by a qualified technician.</p>

## ADVICE FOR SAFE USE OF THE HOB

- Before switching on make sure that you have the correct cooking zone for the hotplate chosen. It is advisable to put the pan on the hotplate before switching on and to take it away after switching off.
- Use cookware with flat and even bottoms. Uneven bottoms can scratch the glass ceramic surfaces. Be careful that the bottom is clean and dry.
- Do not leave wet or damp lids on the hob.
- The glass-ceramic surface and pans must be clean. Carefully eliminate any food remains (especially containing sugar), dirt etc. with the aid of a cleansing agent.
- Make sure that the handles of cookware do not stick out over the edge of the hob, to avoid them being knocked over by accident. **This also makes it more difficult for children to reach the cooking vessels.**
- Do not lean over the cooking zones when they are switched on.
- Do not drop heavy or sharp objects on the glass ceramic cooktop. **If the surface is broken or damaged unplug the cooktop and contact the after-sales service.**
- Do not put aluminium foil or plastic objects on the cooking zones when they are hot.
- Follow the cleaning instructions carefully.

Figure 23

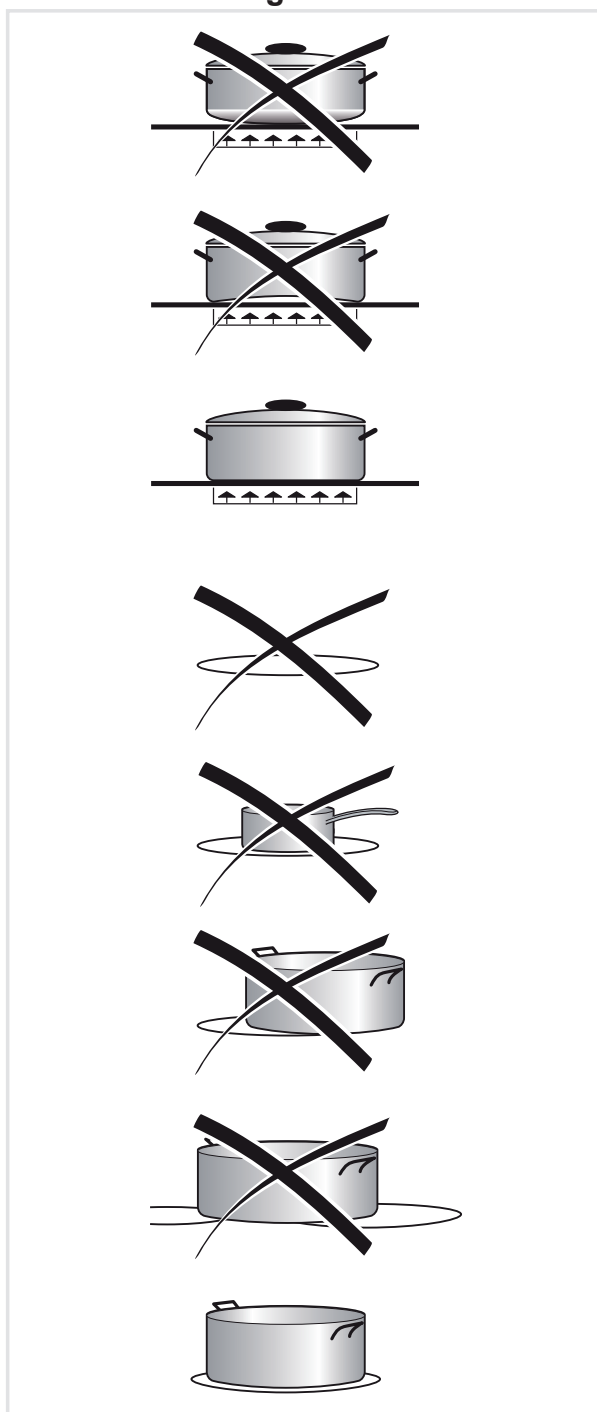

Figure 24

**DO NOT USE PANS WITH ROUGH CIRCULAR MACHINED BASE.**





# CLEANING AND MAINTENANCE

## GENERAL ADVICE

- Before you begin cleaning, you must ensure that the appliance is switched off and disconnected from the electrical power supply.
- It is advisable to clean when the appliance is cold.
- Avoid leaving alkaline or acidic substances (lemon juice, vinegar, etc.) on the surfaces.
- Avoid using cleaning products with a chlorine or acidic base.
- Do not use a steam cleaner because the moisture can get into the appliance thus make it unsafe.
- Important: The use of suitable protective clothing/gloves is recommended when handling or cleaning of this appliance.
- Do not scratch the cooktop with cutting or sharp objects.

## WARNING!

When correctly installed, your product meets all safety requirements laid down for this type of product category. However special care should be taken around the underneath of the appliance as this area is not designed or intended to be touched and may contain sharp or rough edges, that may cause injury.

## CLEANING THE CERAMIC HOB

- Remove spillages and other types of incrustations.
- Dust or food particles can be removed with a damp cloth.
- If you use a detergent, please make sure that it is not abrasive or scouring. Abrasive or scouring powders can damage the glass surface of the hob.
- All traces of the cleaner must be removed with a damp cloth.
- Dust, fat and liquids from food that has boiled over must be removed as soon as possible.
- If they are allowed to harden they become increasingly difficult to remove. This is especially true in the case of sugar/syrup mixtures which could permanently pit the surface of the hob if left to burn on it.
- If any of these products has melted on the ceramic surface, you should remove it immediately (when the surface is still hot) by using a proper scraper to avoid any permanent damage to the surface of the hob.
- Do not put articles on the hob which can melt: i.e plastic, aluminium foil, sugar, sugar syrup mixtures etc.
- Avoid using a knife or other sharp utensil as these may damage the ceramic surface.
- Do not use steel wool or an abrasive sponge which could scratch the surface permanently.

Figure 25



# SERVICE AND MAINTENANCE

## **Servicing the appliance:**

Service may be obtained by contacting our Customer Service Centre to locate the nearest Authorised Delonghi Service Agent:

**Servicing shall be carried out only by authorized personnel.**

**The appliance shall not be modified.**



Descriptions and illustrations in this booklet are given as simply indicative.  
The manufacturer reserves the right, considering the characteristics of the  
models described here, at any time and without notice, to make eventual necessary  
modifications for their construction or for commercial needs.

---

**[www.delonghi.com.au](http://www.delonghi.com.au)**  
**[www.delonghi.co.nz](http://www.delonghi.co.nz)**

**Cod. 1104524 - B1**

