

I

DAILY 4x4

USE AND MAINTENANCE

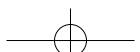

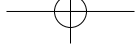

On the following pages, you will often find these symbols; for your own safety and that of your vehicle, carefully follow the related instructions.

Risk of injury: failure to comply with these prescriptions can result in the risk of serious injury.

Risk of serious damage to the vehicle: Failure to comply with these prescriptions can result in the risk of serious damage to the vehicle and may even invalidate the warranty.

General risk: combines the risks of both the signs described above.

Protecting the environment: indicates the correct behaviour so that vehicle use is as environmentally friendly as possible.

CONTENTS

The driver's position	5
Controls and devices	117
Starting and driving	151
On board equipment	193
Quick intervention	197
Inspections to be carried by the user	217
Scheduled maintenance	233
Technical characteristics	249
Plates	267
Fuses	271
Alphabetical index	283

Directive 2000/53: Information on withdrawing end-of-life vehicles

The European Union has issued Directive 2000/53/EC with the aim of reducing the impact of end-of-life vehicles on the environment, promoting the prevention of waste production and contributing to the protection, preservation and improvement of the quality of the environment.

The regulations require both the implementation of preventive measures, during the phase of vehicle design and construction, and the implementation of systems to collect and process, recover and recycle them once they have finished their life cycle.

What has Iveco done and what is it doing for the environment?

The environmental performance of a vehicle goes beyond its cycle of use and covers its entire life cycle. For years Iveco has made a global commitment to the environment by continually improving its production processes and making increasingly more eco-friendly products. In fact, together with ongoing research for process and product technologies with high energy efficiency and environmentally-friendly performance, already in the design and construction stages of its products, IVECO has created solutions that provide for the use parts and materials that can be recovered and recycled with minimal environmental impact.

In compliance with the current European regulations and to make sure all its customers receive an excellent service for handling vehicles to be scrapped, IVECO has developed a system that enables customers to take them, with no additional costs (1), to a certified network of wreckers.

The customer can contact the Iveco dealer network for information on the nearest authorized demolition centre. Iveco has carefully selected the demolition centres in order to ensure a service in compliance with excellent quality standards for collecting, treating and recycling disused vehicles.

It is also possible to obtain information on the authorised wrecking centres by visiting the website www.iveco.com.

(1) Vehicles for transporting goods or passengers up to a total weight of 3.5 t, containing all the essential components (especially engine and bodywork) and free from additional waste.

Installation of accessories, < additions and modifications to the vehicle must be carried out in compliance with the IVECO assembly directives (the specific publication "Directives for conversion and setups" is available from the Service Network workshops).

In particular regarding the electrical system, different electrical outlets are provided standard (or as optionals) to simplify and aid electrical operations by fitters.

IVECO authorisation is required for any exception to the assembly directives. Failure to comply with the above prescriptions will invalidate the warranty.

The driver's position

The cab of your vehicle has been designed in accordance with current standards of ergonomics to offer you a roomy, welcoming and safe environment.

This section describes the following elements:

Doors	7
STANDARD VERSION	
Instrument panel	9
Menu keypad	16
Display	20
Scheduled maintenance function display	21
Seat belts not fastened function display	23
Odometer display	24
Menu layout	25
COMFORT VERSION	
Instrument panel	41
Menu keypad	48
Display	52
Scheduled maintenance function display	53
Seat belts not fastened function display	54
Viewing messages on the display	55
Menu layout	56
DPF (Diesel Particulate Filter)	112
Central dashboard	114

THE DRIVER'S POSITION

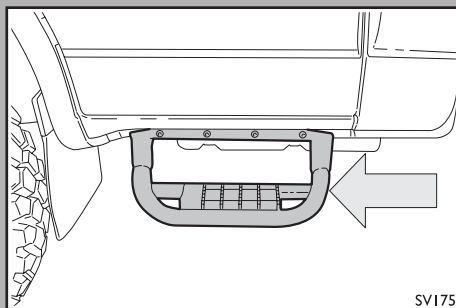
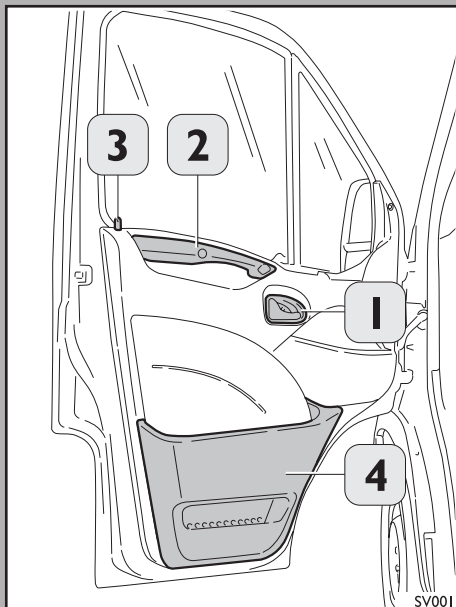

Front doors

1. Lever for opening the door.
2. Door handle.
3. Knob for locking the door from inside.
4. storage pocket.



CAUTION!

Risk of injury and accident!

- Travel only with the doors properly closed.
- Never jump out of the vehicle.
- Keep the cab access step clean.



> **CAUTION!**

Risk of injury and accident!

- Travel only with the doors properly closed.
- Never jump out of the vehicle.
- Keep the cab access step clean.

Rear doors

1. Lever for opening the door.
2. Door handle.
3. Knob for locking the door from inside.
4. Ashtray.

THE DRIVER'S POSITION

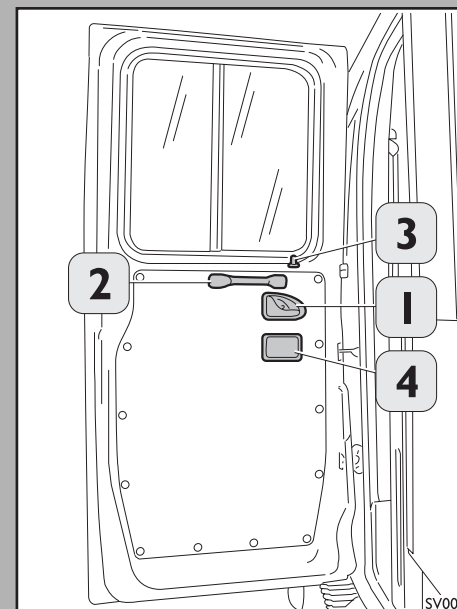

THE DRIVER'S POSITION

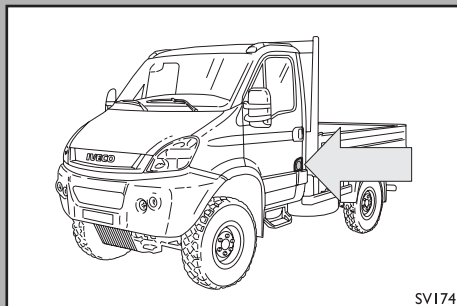

Fuel filler cap opening

The fuel tank cap (1) is located near the front door.



CAUTION!

- Switch off the supplementary heater (in vehicles equipped with this device) before refuelling.
- If the fuel cap has to be replaced, ask the Service Network for the specific one for the vehicle model.
- Avoid spilling fuel when refilling. Fuel contains alcohol which could damage the paintwork.

Safety at service stations

Fuel vapours are extremely flammable and can even be explosive in enclosed spaces. Always take the following precautions when refilling:

- Switch off the engine.
- Do not smoke or use anything that can produce flames.
- Avoid spilling fuel.



THE DRIVER'S POSITION

> **STANDARD version instrument panel**

IMPORTANT USE AND SAFETY INSTRUCTIONS

The systems fitted to your vehicle enable you to check and easily use the main function controls, if necessary. To avoid creating potentially dangerous situations, also for other road users, please carefully comply with the following precautions:

The system must be used, always maintaining full control of the vehicle; in case of doubt, stop and carry out the various operations / adjustments.

Lack of attention and/or loss of view of the road by the driver can be a source of serious accidents.

Before starting out, become familiar with the vehicle's systems and other controls.

Driver comfort: It is the responsibility of the driver to ensure that they are in the best possible position to assure both their own and other road user's safety. Use the seat and steering wheel adjustments to obtain the most comfortable driving position. When driving, the driver's comfort depends on many external factors, such as the road surface, speed, vehicle load, etc. The driver must respond to these external factors in order to maintain comfort, and often, especially when the road surface is in a poor condition or on dirt roads, the only factor he can control is the vehicle's speed. In these conditions the driver must maintain a speed compatible with their own comfort.

Standard version instrument panel
not applicable in Australia

THE DRIVER'S POSITION

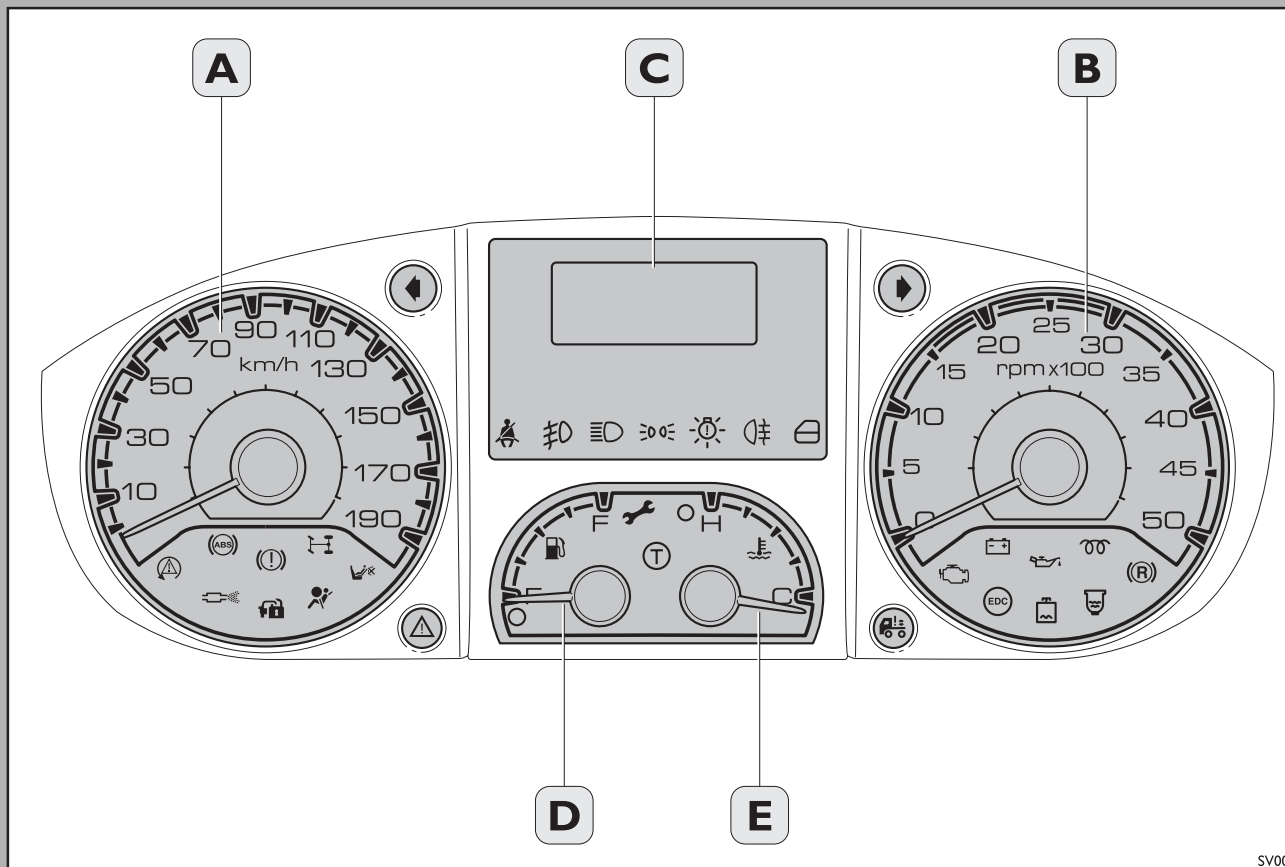

THE DRIVER'S POSITION

* The operation of the warning lights highlighted with an asterisk is checked automatically each time the key is turned ON for the duration of a few seconds.











A= Speedometer / Tachograph

B = Rev counter

C = Multifunction display

D = Fuel level indicator and yellow reserve warning light

E = Engine coolant thermometer and red high temperature warning light





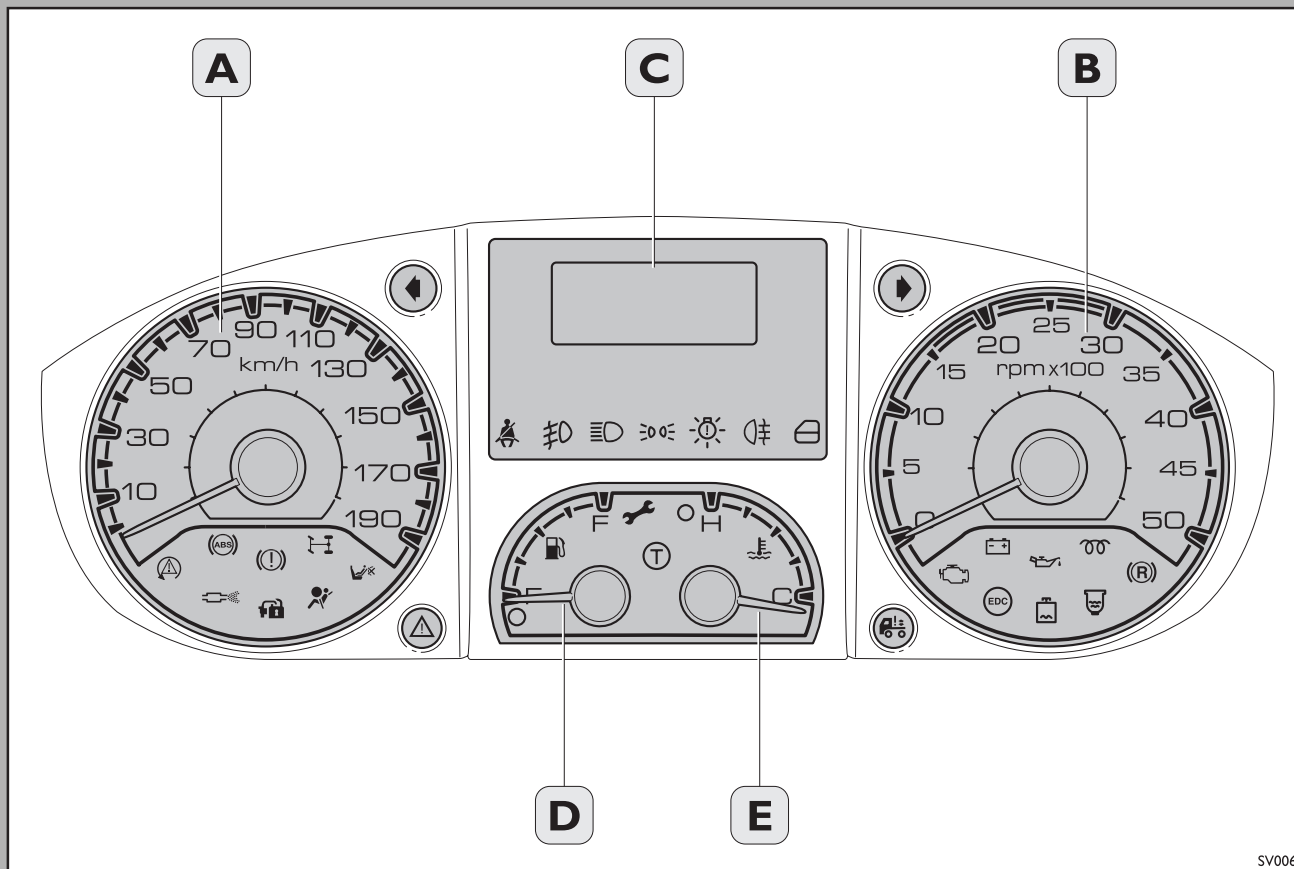



MEANING	IDEOGRAM	COLOUR
*ABS failure		yellow
DPF		yellow
*Brake failure/ EBD failure/ Parking brake on		red
*Vehicle protection system failure		yellow
Differential lock engaged		yellow
*Airbag failure		red
*Deactivation of passenger airbag		yellow
Left direction indicator		green
General malfunction		yellow
Driver's seat belt not fastened		red
Fog lamps		green

THE DRIVER'S POSITION



THE DRIVER'S POSITION

*The operation of the warning lights highlighted with an asterisk is checked automatically each time the key is turned ON for the duration of a few seconds.





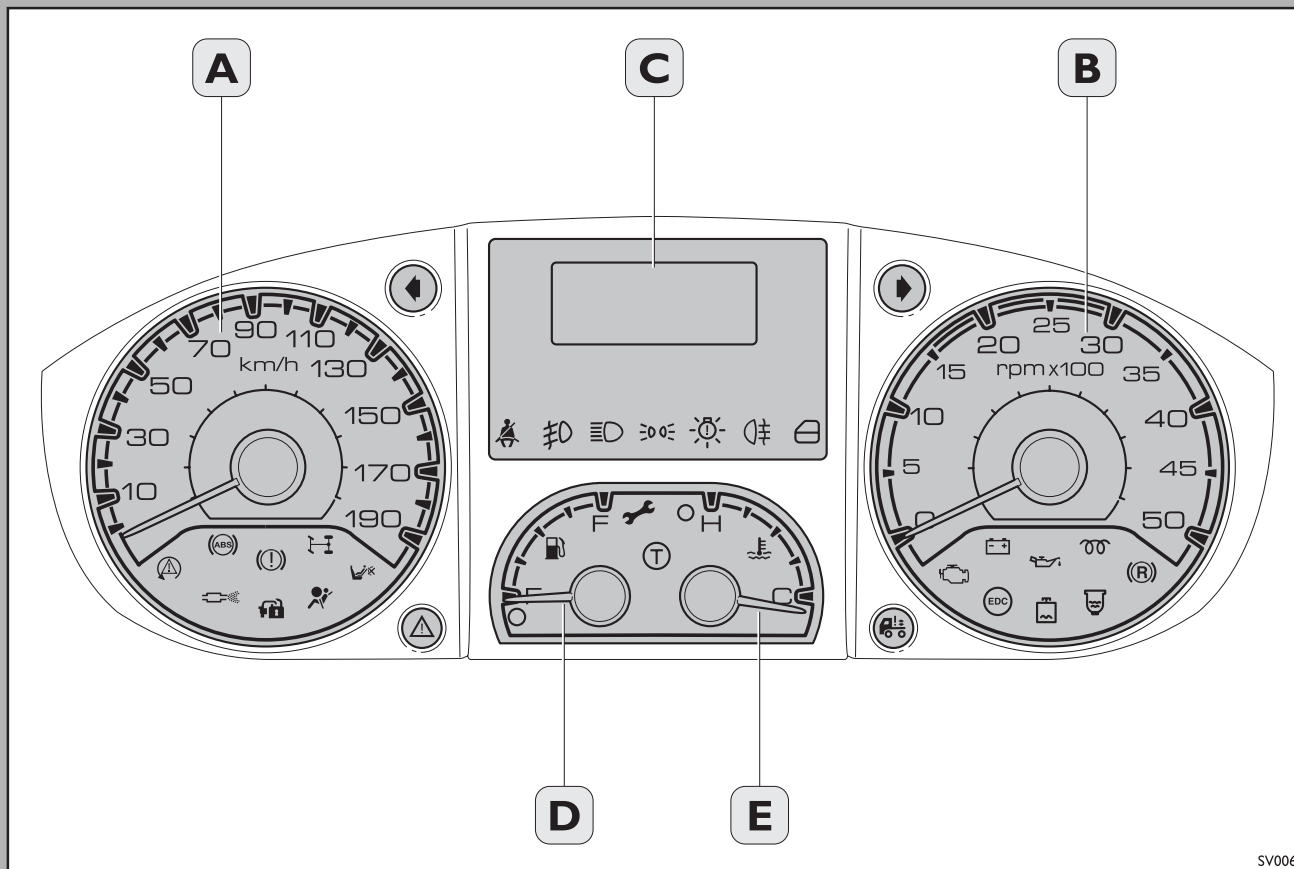

MEANING	IDEOGRAM	COLOUR
High beams		blue
Parking side lights		green
External lights failure		yellow
Rear fog lamps		yellow
Doors open		red
*Scheduled maintenance		yellow
*Tachograph failure		yellow
Right direction indicator		green
*EOBD		yellow

THE DRIVER'S POSITION



THE DRIVER'S POSITION

*The operation of the warning lights highlighted with an asterisk is checked automatically each time the key is turned ON for the duration of a few seconds.

MEANING	IDEOGRAM	COLOUR
No battery charging		red
*EDC failure		red
*LOW ENGINE OIL PRESSURE		red
*Engine coolant level low		red
Glow plug pre-heating		yellow
*Water in fuel filter		yellow
*Retarder engaged		yellow

THE DRIVER'S POSITION

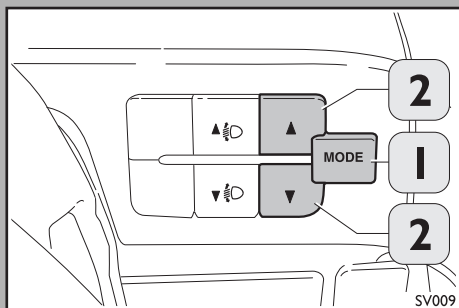

Menu keypad

Located on dashboard behind the right steering wheel lever.

1. MODE button short press (less than 1 second).

- With the vehicle stationary and complete menu shown on the display.

With the vehicle moving, activating and displaying the menu in reduced form.

- Confirm selected function.
- Confirm modification/adjustment made and return to the main menu screen.

1. MODE button long press (more than 1 second).

- Save confirmed changes with short press and return to the main screen.

2. Increase/decrease buttons "+/-".

- Select functions on the menu.
- Select/adjust functions on the menu.

Adjustment of the functions (e.g. clock) occurs in increasingly shorter steps, depending on how long the button is pressed.

THE DRIVER'S POSITION

Control method

The control modes differ from each other according to the nature of the selected item.

A) SELECT AN ITEM FROM THE MAIN MENU WITHOUT SUBMENU

- Briefly press (less than one second) the "MODE" button to select the setting of the main menu to be modified.
- Using the "+" or "-" button (single presses) it is possible to select the new setting.
- By briefly pressing (less than one second) the "MODE" button you can save the setting and at the same time go back to the same item of the main menu previously selected.

B) SELECT AN ITEM FROM THE MAIN MENU WITH SUBMENU

- By briefly pressing (less than one second) the "MODE" button you can view the first item of the submenu.
- By using the "+" or "-" buttons (single presses) you can scroll through all the items of the submenu
- By briefly pressing (less than one second) the "MODE" button you can select the displayed item of the submenu and access the setting menu.
- By using the "+" or "-" buttons (single presses) you can select the new setting of this item of the submenu.
- By briefly pressing (less than one second) the "MODE" button you can save the setting and at the same time return to the same item of the submenu previously selected.

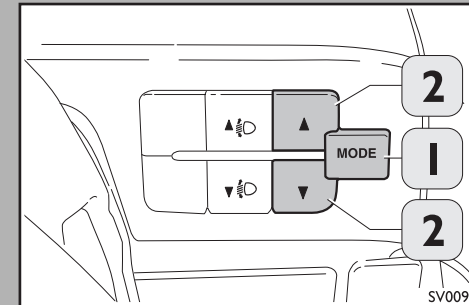

THE DRIVER'S POSITION

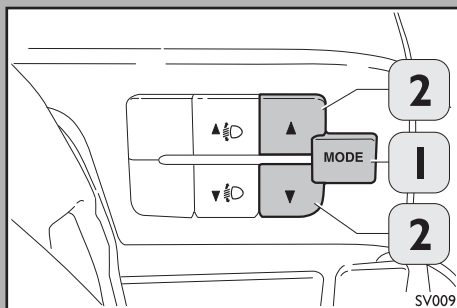

C) SELECTION OF DATE AND CLOCK SETTING FUNCTIONS

- By briefly pressing (less than one second) the "MODE" button you can select the first figure to change (hours/minutes or year/month/day).
- Using the "+" or "-" buttons (single presses) it is possible to select the new setting.
- By briefly pressing (less than one second) the "MODE" button you can save the setting and at the same time move on to the next item of the setting menu and, if this is the last one, you go back to the same item of the main menu previously selected.

D) PASSENGER AIRBAG ON/OFF

- By briefly pressing (less than one second) the "MODE" button you can decide whether to turn the passenger airbag on/off.
- By using the "+" or "-" buttons (single presses) you can select the new setting, by briefly pressing (less than one second) the "MODE" button you can decide whether to confirm the setting; the confirmation request must occur even if the original setting was not changed.
- By using the "+" or "-" buttons (single presses) you can select the new setting (selection confirmed/not confirmed).
- If confirmed by briefly pressing (less than one second) the "MODE" button, a confirmation message is displayed, after which you go back to the same item of the main menu previously selected.
- If not confirmed (by briefly pressing the "MODE" button for less than one second), you go back to the same item of the main menu previously selected, without displaying the confirmation message.

THE DRIVER'S POSITION

Display

1. Request to turn passenger airbag on / off.
2. Request for confirmation.
3. Airbag status message.

Notes:

By pressing the MODE button (for more than one second):

- If you are at the level of the main menu you exit the menu environment, if you are at any other level you go to the level of the main menu.
- Only the changes already saved by the user are saved.

The menu environment is on a time setting: at the end of the time, without any other operations being carried out, only the changes already saved by the user are saved.

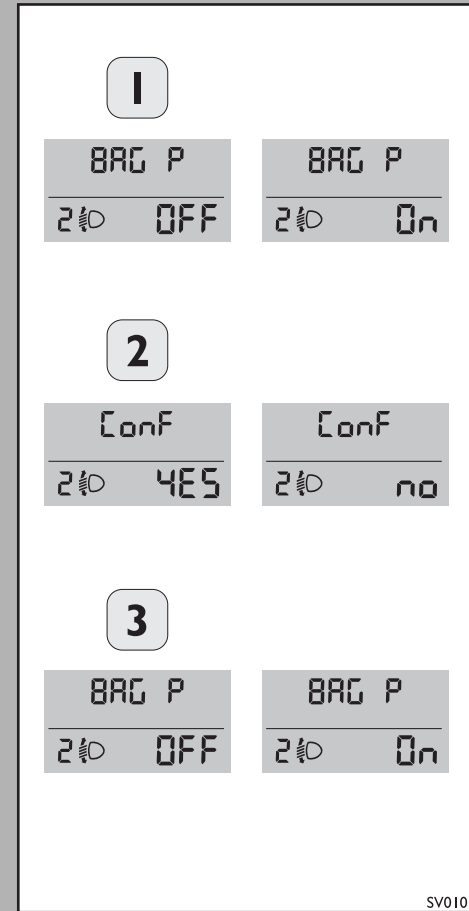

THE DRIVER'S POSITION

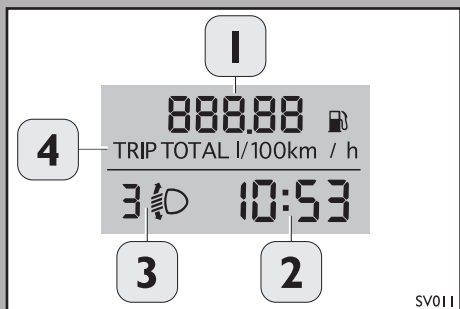

STANDARD version display

1. total odometer.
2. Clock.
3. Headlamp levelling adjuster indicator.
4. Trip computer data.

Scheduled maintenance function display

At the end of a partial threshold, the display can show three modes:

1. distance to the next SERVICE.
 2. days to the next SERVICE.
 3. hours of operation to the next SERVICE.
1. Distance to the next SERVICE (example illustration above to the side).
 - At the top the display shows the distance to the next SERVICE .
 - In the middle it displays the selected unit of measurement for the distance (km or miles).
 - It is displayed simultaneously with the “spanner” warning light coming on and stops after a programmed length of time.
 2. Days to the next SERVICE (example illustration at the bottom to the side).
 - At the top the display shows the days to the next SERVICE.
 - At the bottom the letter “d” is displayed.
 - It is displayed simultaneously with the “spanner” warning light coming on and stops after a programmed length of time.

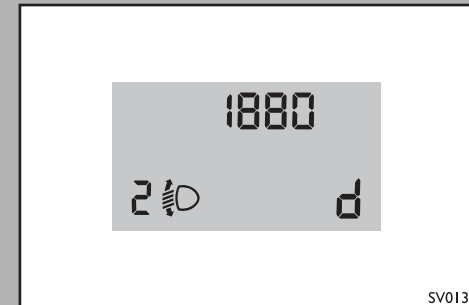
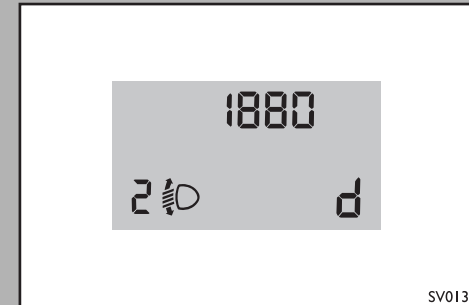

THE DRIVER'S POSITION

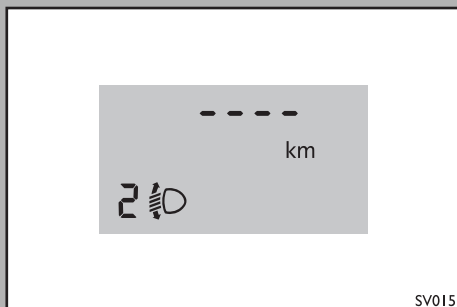
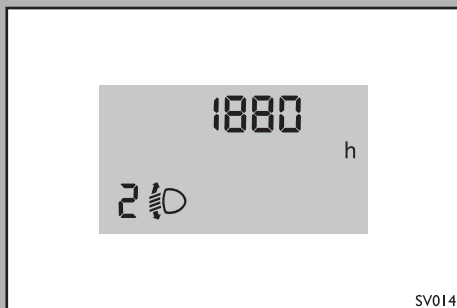

3. Hours of operation to the next SERVICE (example illustration opposite, above).

- At the top the display shows the hours of operation to the next SERVICE.
- In the middle the hour symbol "h" is displayed.
- It is displayed simultaneously with the "spanner" warning light coming on and stops after a programmed length of time.

At the time for the scheduled service the display appears as follows (example illustration at the bottom to the side):

- Dashes are displayed at the top.
- In the middle it displays the selected unit of measurement for the distance (km or miles) or the indication "d" or "h" for the hours (see above examples).
- The "spanner" warning light stays on for the next 100 km or 2 days or 2 hours of operation.

This function must be considered a reminder for the driver, for the main maintenance times.

For the validity of the warranty and to ensure the lasting efficiency of the vehicle, carefully comply with the IVECO scheduled maintenance plan, given inside this publication.

THE DRIVER'S POSITION

Safety belts not fastened signalling display

The "seat belts" warning light signals that the driver's seat belt has not been fastened and stays on fixed after starting the engine if the seat belt has not been fastened. In addition, when the first of the following events occurs:

- a. Time elapsed equal to 180 seconds and vehicle speed detected greater than 10 km/h.
- b. Vehicle speed higher than 25 km/h.
- c. Distance travelled greater than 500 metres.

The warning light blinks and a buzzer sounds until the seat belt is fastened.

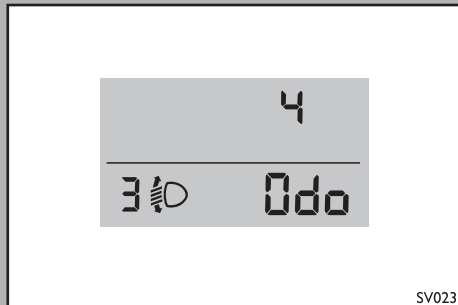
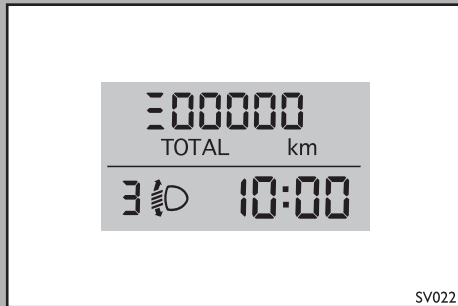

THE DRIVER'S POSITION**Odometer display**

On reaching a mileage of 400,000 km, the instrument panel resets, displaying a symbol of three horizontal segments on the first significant digit of the odometer, and the kilometre count will restart from 0.

When 400,000 km are exceeded, it provides the user with an additional screen on the display, by means of the MODE button (on the menu control keypad), indicating the value of the first significant digit, i.e. for 400,000 km it displays 4 associated with the message "ODO". From here on, the main odometer resets whenever it reaches 99,999 km and the most significant digit associated with the message "ODO" will increase up to a maximum value of 9.

THE DRIVER'S POSITION

STANDARD version menu layout - Vehicle starting (key ON)

Key

Mode 1 = button pressed for less than two seconds.

Mode 2 = button pressed for more than two seconds.

Trip 1 = button pressed for less than two seconds.

Trip 2 = button pressed for more than two seconds.

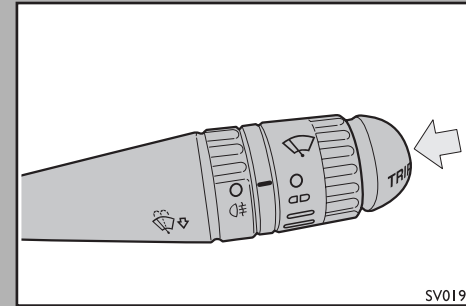
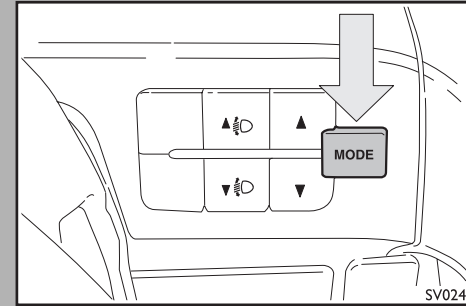

THE DRIVER'S POSITION

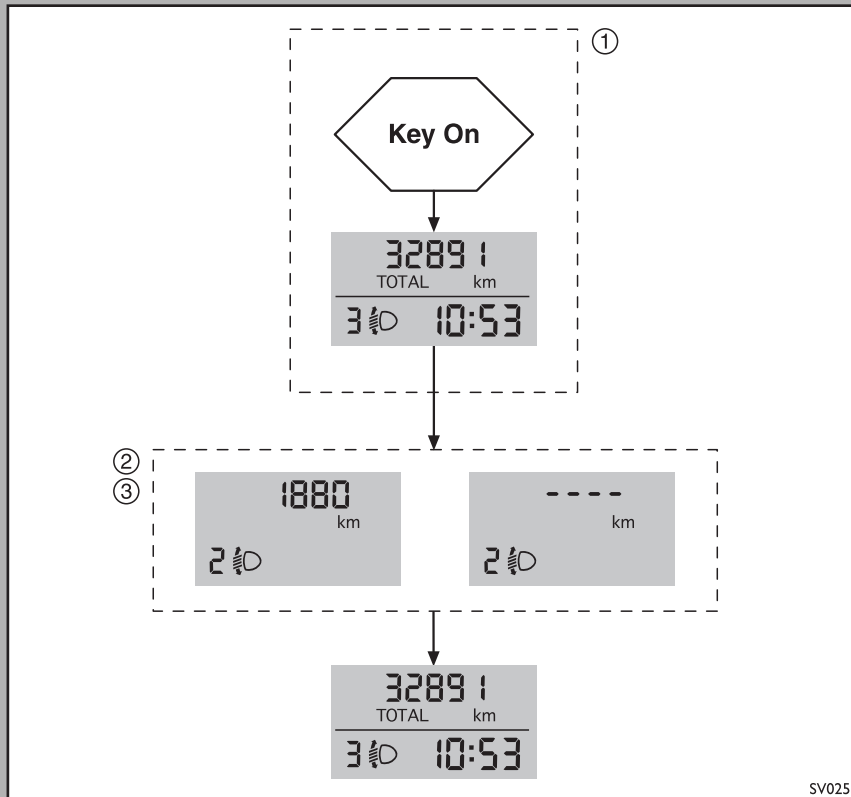

1. The total odometer is displayed when the vehicle is started.

2. Scheduled maintenance signalling occurs just once after turning the key ON, when the value of km/hours/days to the service is below a new threshold.

3. Scheduled maintenance (due) signalling occurs each time the key is turned ON (but only for the 1000 km/20 hours/20 days following the first time due).

THE DRIVER'S POSITION

STANDARD version menu layout - Exceeding speed limit

1. The warning disappears when 5 km under the activation threshold.
2. 10 seconds or MODE button.

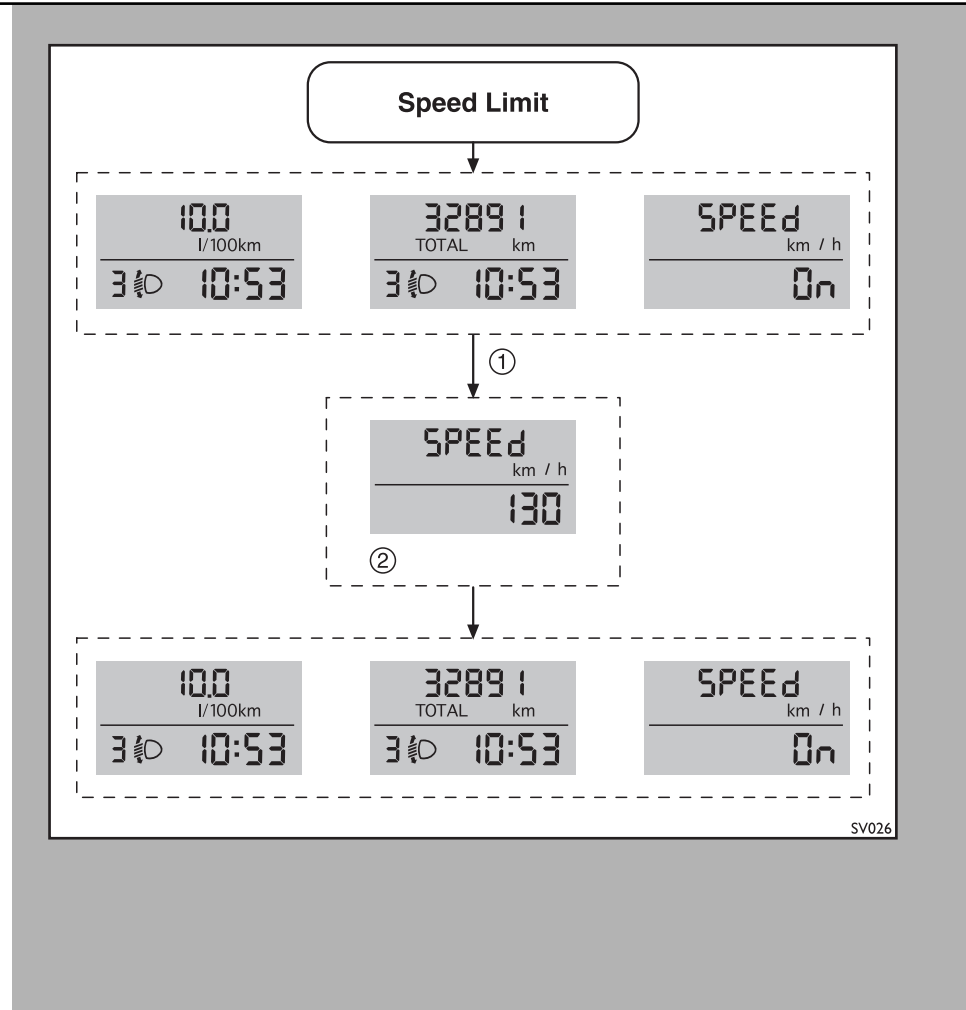

THE DRIVER'S POSITION

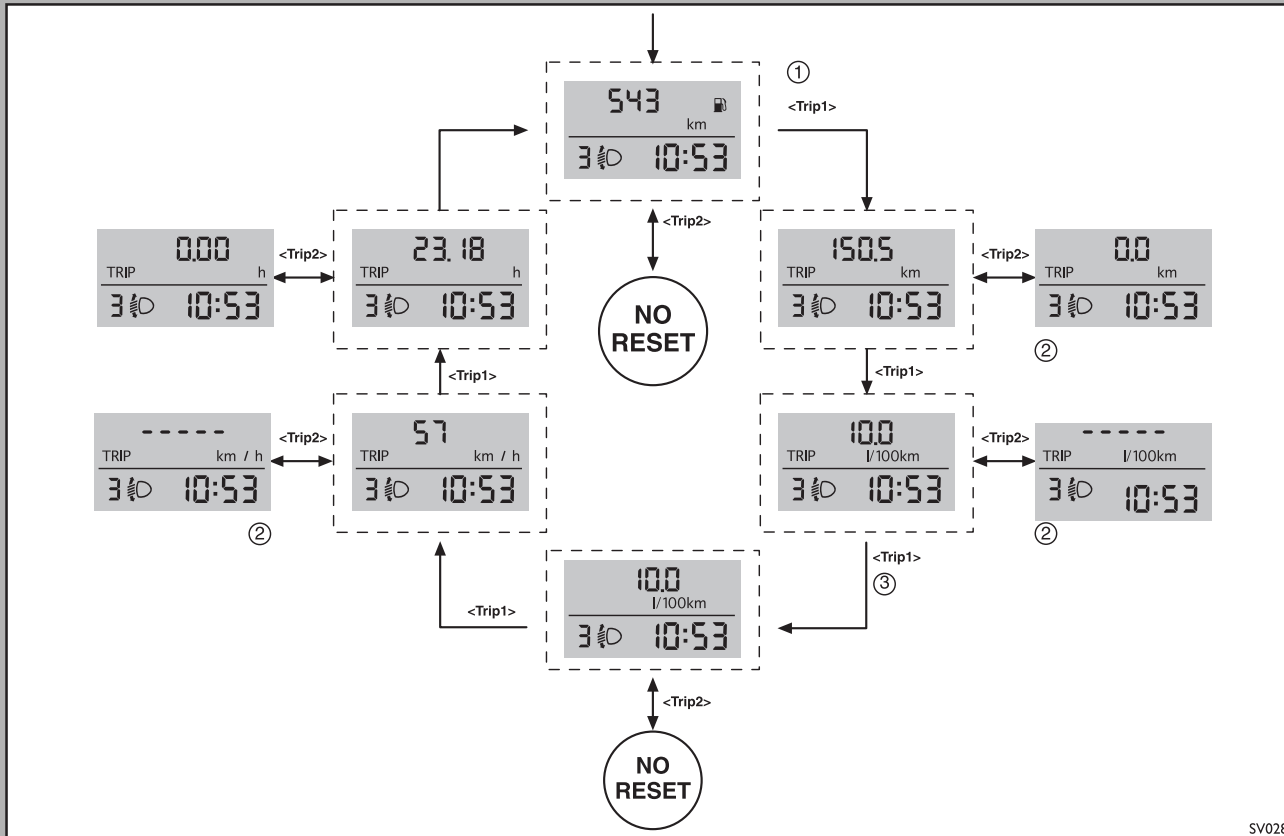

THE DRIVER'S POSITION

STANDARD version menu layout - Trip computer (1)

1. Display of TRIP information not permitted with warnings displayed.
2. Return to the previous screen with updated display.
3. Note: During the initial particulate trap regeneration stage, consumption cannot be measured (the display shows the message "rig").

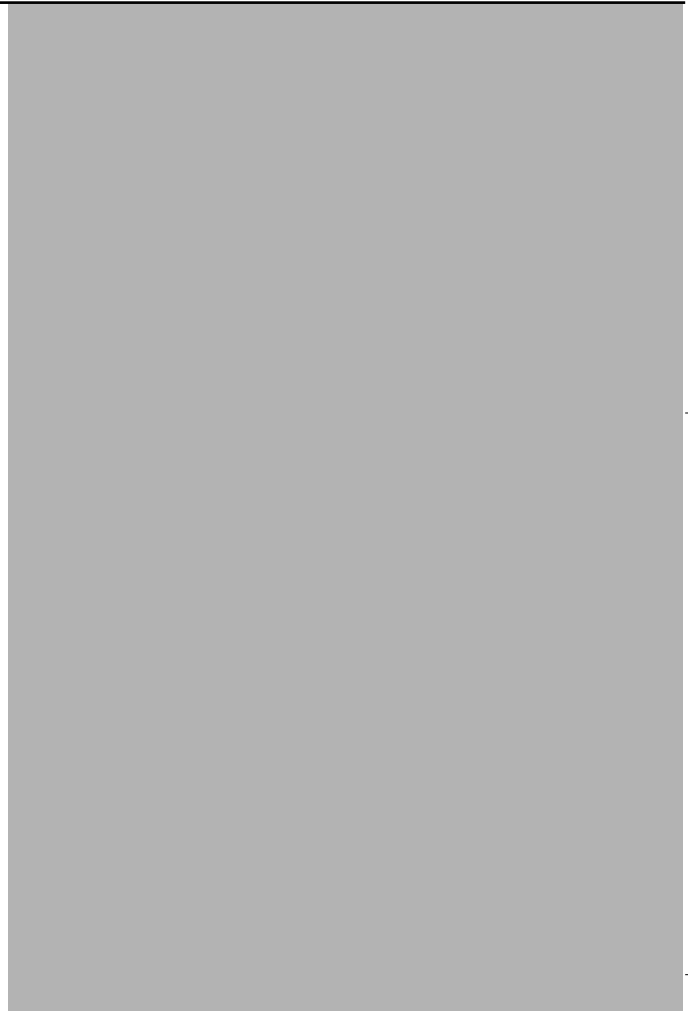

THE DRIVER'S POSITION

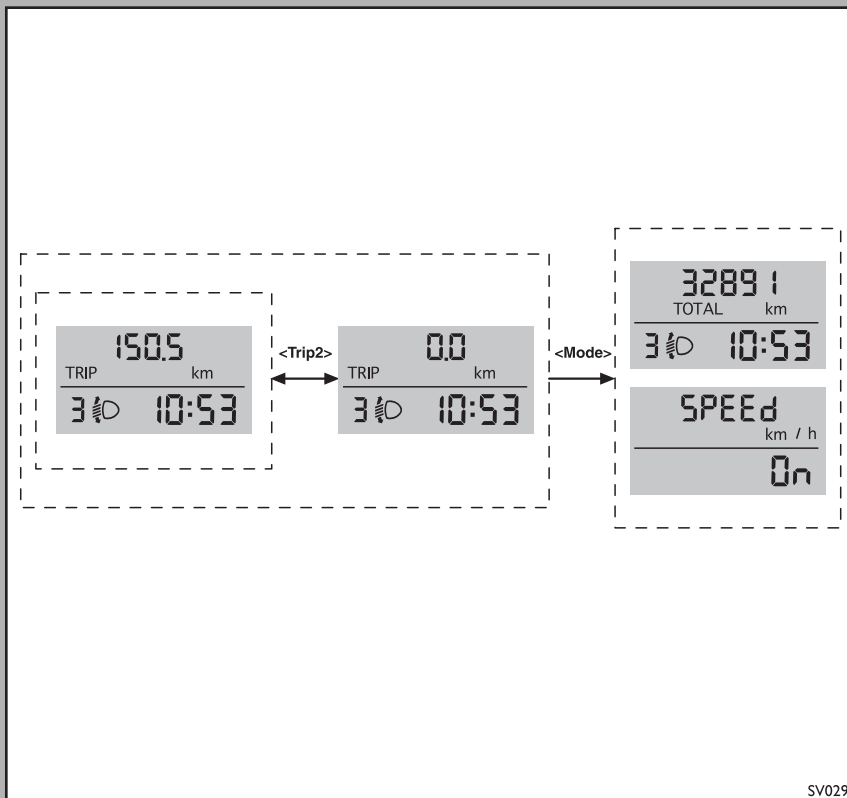

THE DRIVER'S POSITION

STANDARD version menu layout - Trip computer (2)

I. Return to the previous screen with updated display.

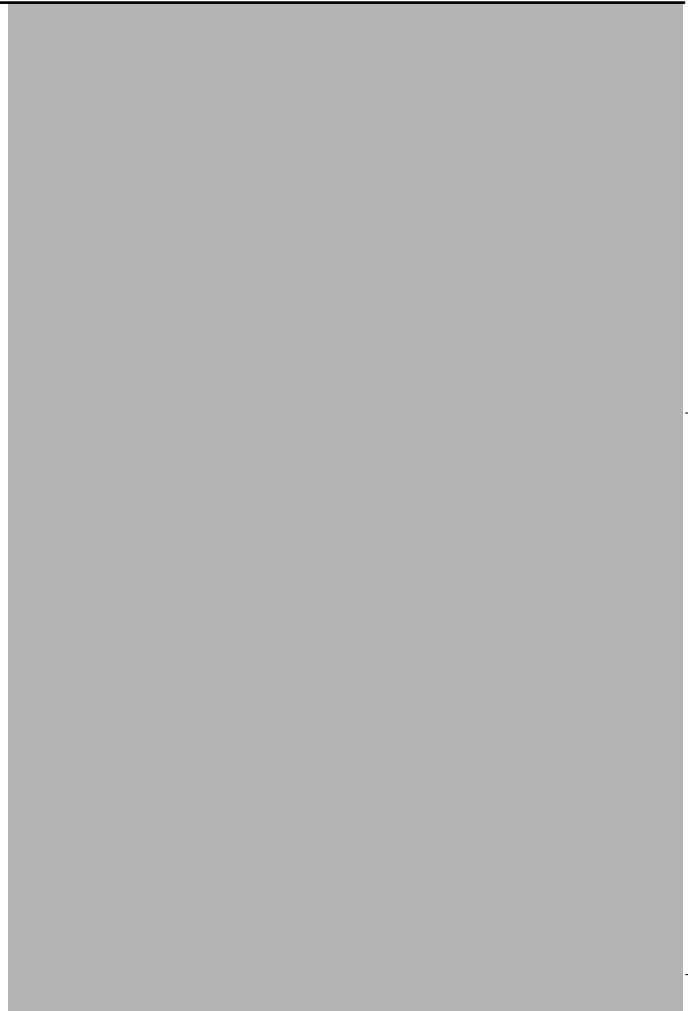

THE DRIVER'S POSITION

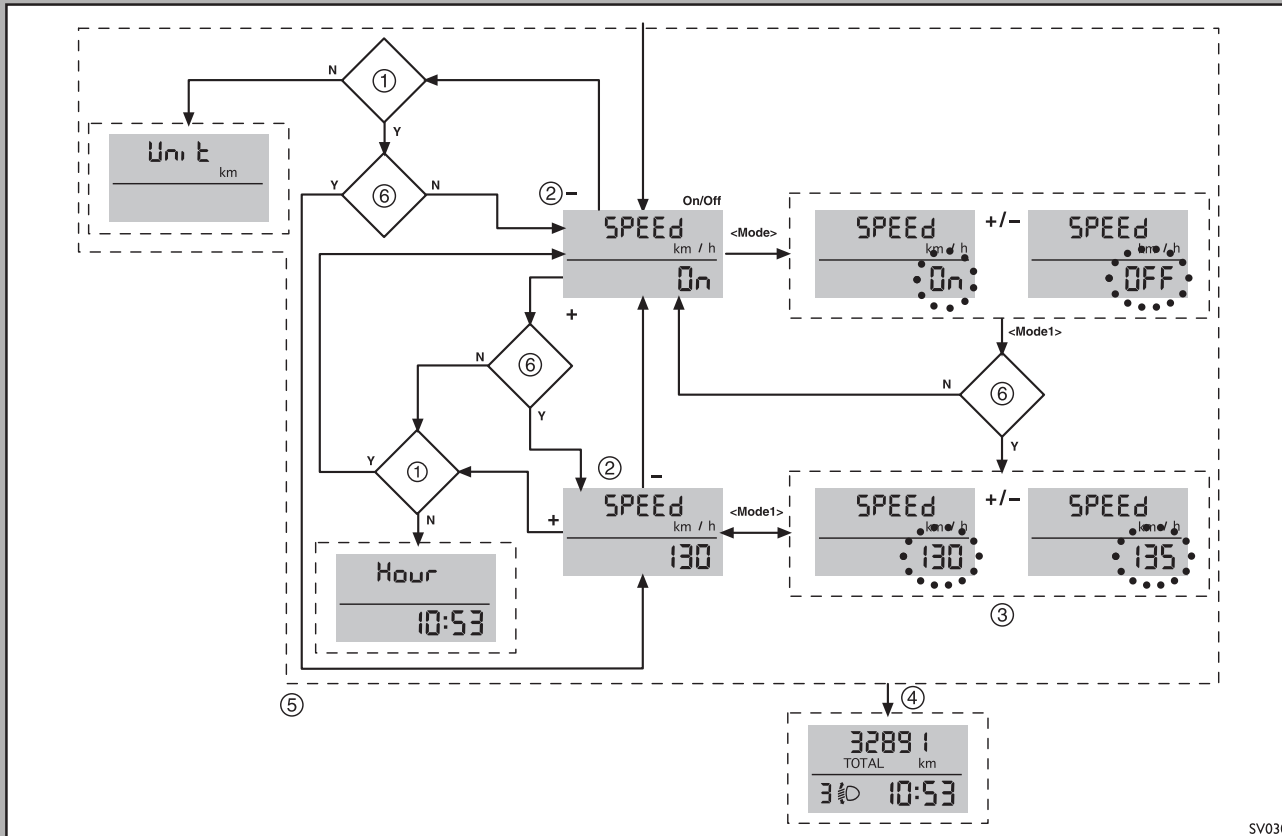

STANDARD version menu layout - general menu

1. Vehicle moving.
2. The + and - buttons both switch from ON to OFF and vice versa. Mode 1 confirm the set value. The ON/OFF indication blinks.
3. Speed threshold adjustment with + and - buttons (steps of 5 km/h to reach the max and min thresholds).
Mode 1 confirm the set value.
The indication will blink.
4. Mode 2 or end of time period with no action.
5. Important: During the menu display, with no events for a set time, or with the vehicle in motion (while viewing a function that is not permitted with the vehicle in motion) you exit the menu and go back to the standard screen. During menu display, if a warning condition occurs, the relevant message is displayed and when the warning ends the display goes back to the menu page being viewed before the warning. In any case, when you exit the menu only the previously saved parameters remain adjusted. Turning the key OFF exits the menu.
6. Speed limiter engaged?

THE DRIVER'S POSITION

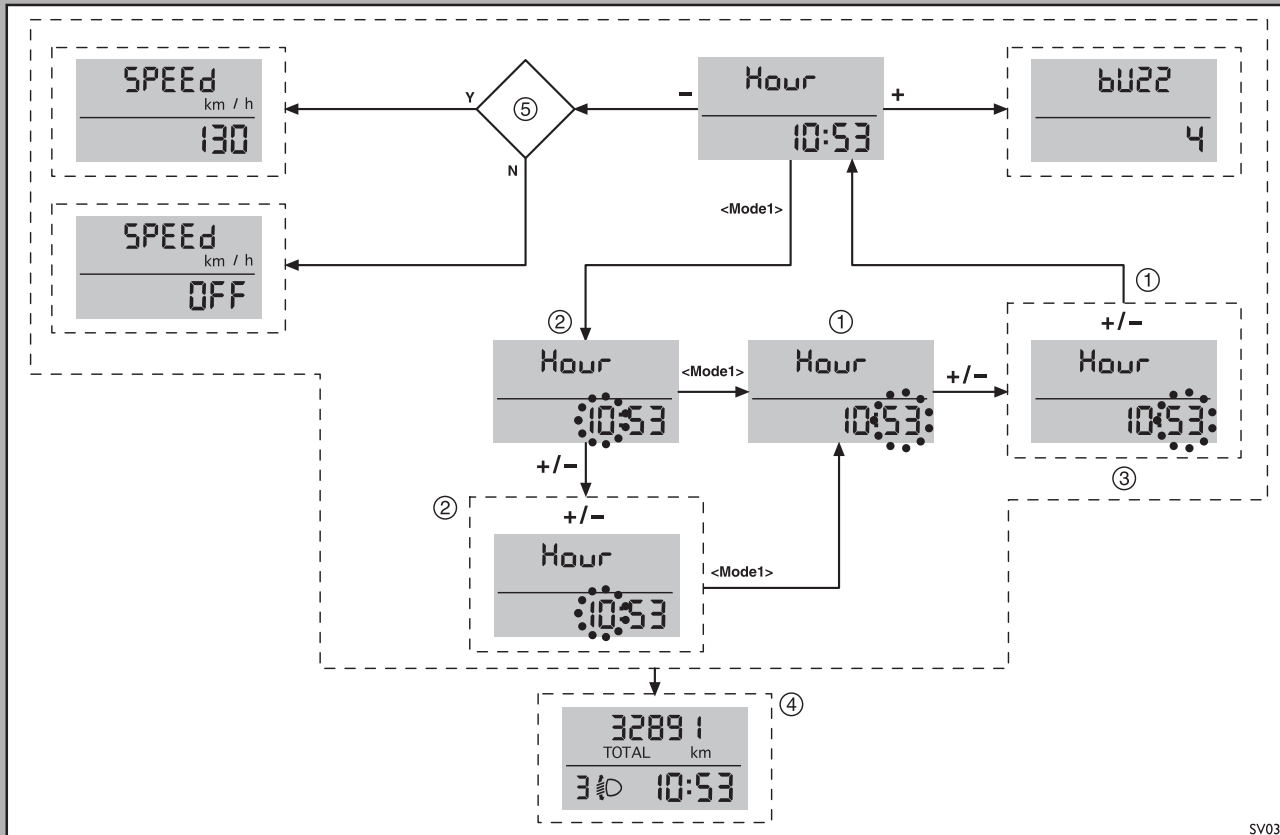

STANDARD version menu layout - clock adjustment

1. The minutes indication will blink.
2. The hour indication will blink.
3. The + and - buttons are used to change the Hour and Minutes.
Mode 1 confirm the set value. During the adjustment the value (Hour or Minutes) will blink.
4. Mode 2 or vehicle in motion or end of time period with no action.
5. Speed limiter engaged?

THE DRIVER'S POSITION

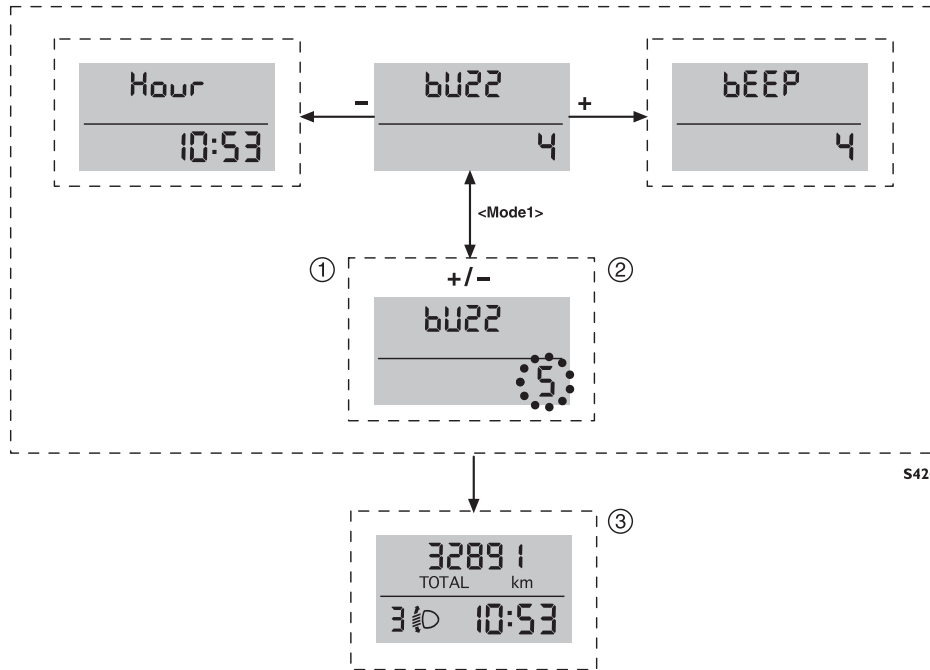

S420

THE DRIVER'S POSITION

STANDARD version menu layout - buzzer volume adjustment

1. The value will blink during adjustment.
2. A buzzer will sound during adjustment.
3. Mode 2 or vehicle in motion or end of time period with no action.

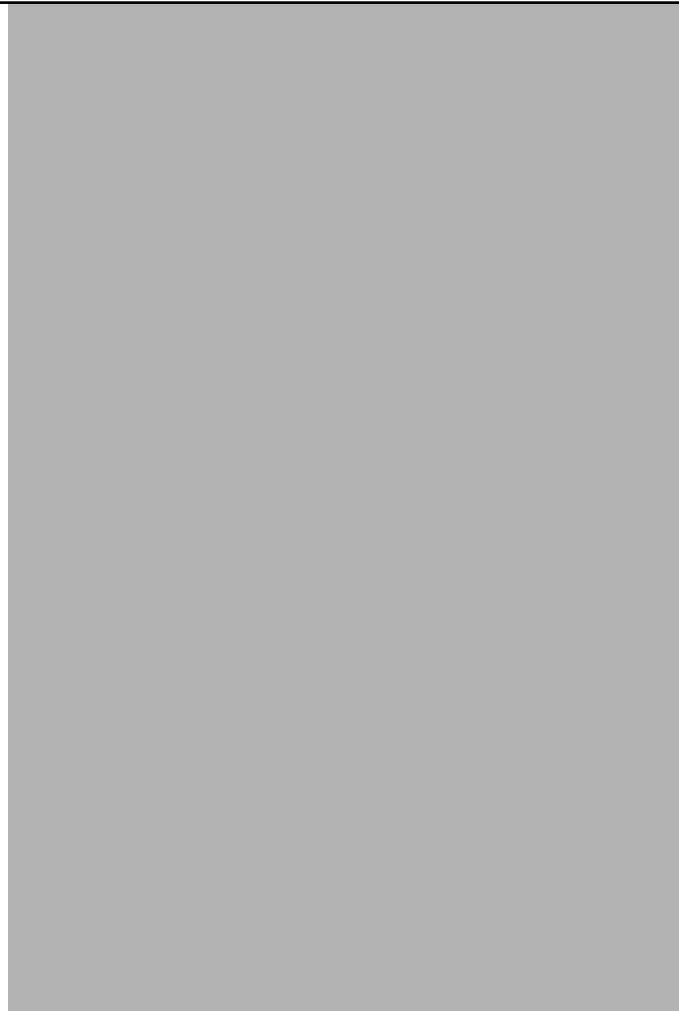

THE DRIVER'S POSITION

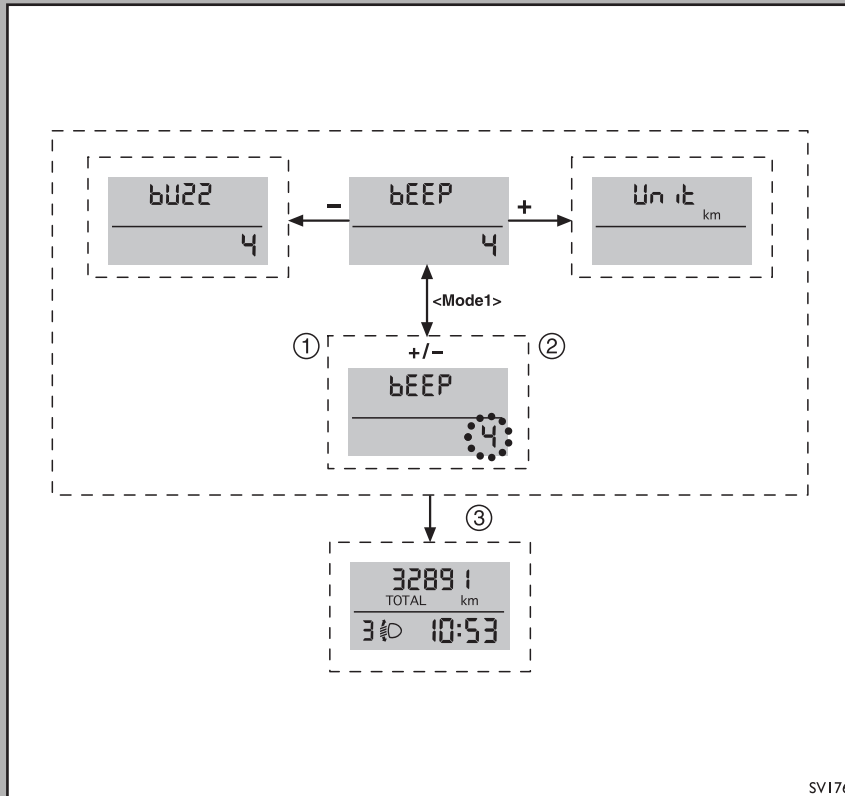

SV176

STANDARD version menu layout - button volume adjustment

1. The value will blink during adjustment.
2. A buzzer will sound during adjustment.
3. Mode 2 or vehicle in motion or end of time period with no action.

THE DRIVER'S POSITION

STANDARD version menu layout - km/miles unit distance

1. The unit of measurement will blink during adjustment.
2. Mode 2 or vehicle in motion or end of time period with no action.

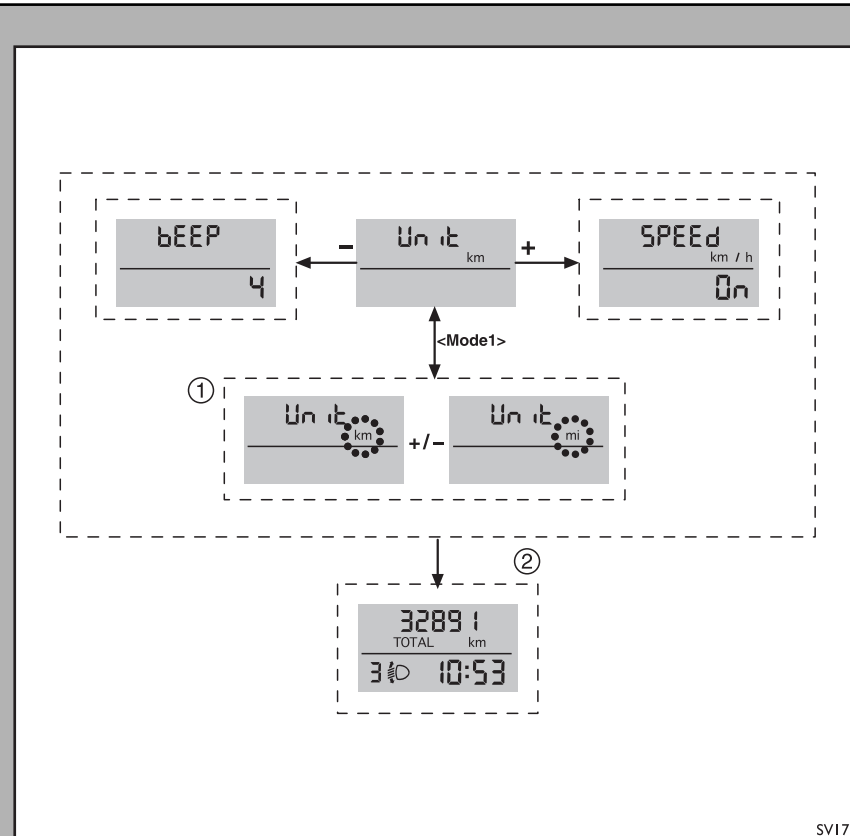

THE DRIVER'S POSITION

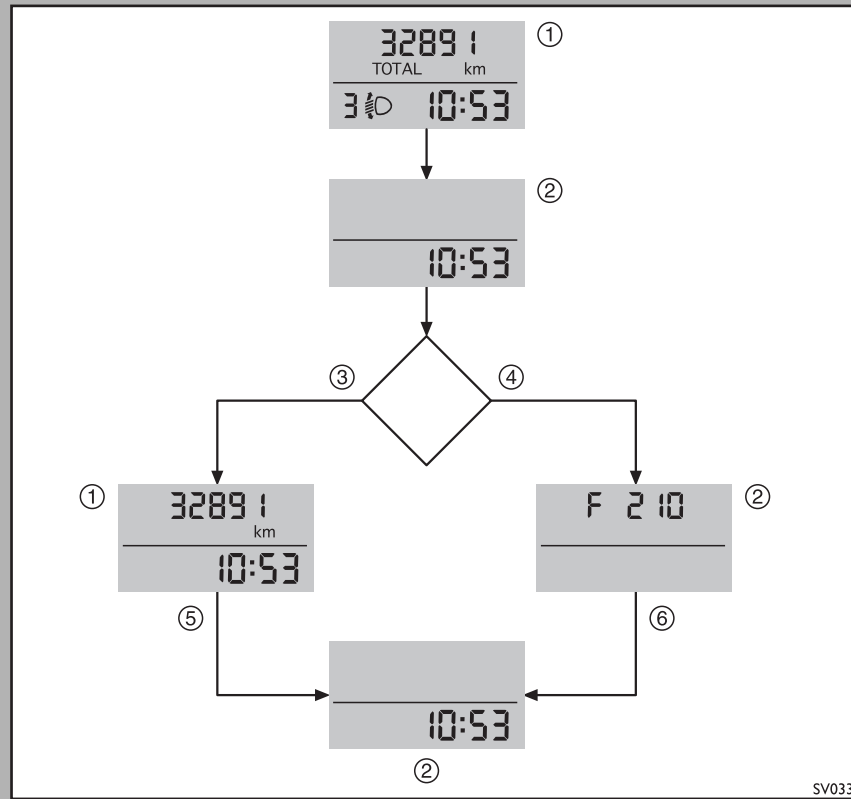
STANDARD version menu layout - vehicle stop
(key OFF)

1. Backlighting ON.
2. Backlighting OFF.
3. Doors opening.
4. High beam headlight flasher control (follow me home).
5. 10 seconds.
6. 20 seconds.



THE DRIVER'S POSITION

> **COMFORT version instrument panel**

IMPORTANT USE AND SAFETY INSTRUCTIONS

The systems fitted to your vehicle enable you to check and easily use the main function controls, if necessary. To avoid creating potentially dangerous situations, also for other road users, please carefully comply with the following precautions:

The system must be used, always maintaining full control of the vehicle; in case of doubt, stop and carry out the various operations and adjustments.

Lack of attention and/or loss of view of the road by the driver can be a source of serious accidents. Before starting out, become familiar with the vehicle's systems and other controls. Driver comfort: It is the responsibility of the driver to ensure that they are in the best possible position to assure both their own and other road user's safety. Use the seat and steering wheel adjustments to obtain the most comfortable driving position. When driving, the driver's comfort depends on many external factors, such as the road surface, speed, vehicle load, etc. The driver must respond to these external factors in order to maintain comfort, and often, especially when the road surface is in a poor condition or on dirt roads, the only factor he can control is the vehicle's speed. In these conditions the driver must maintain a speed compatible with their own comfort.

Comfort version instrument panel is standard in Australia

THE DRIVER'S POSITION

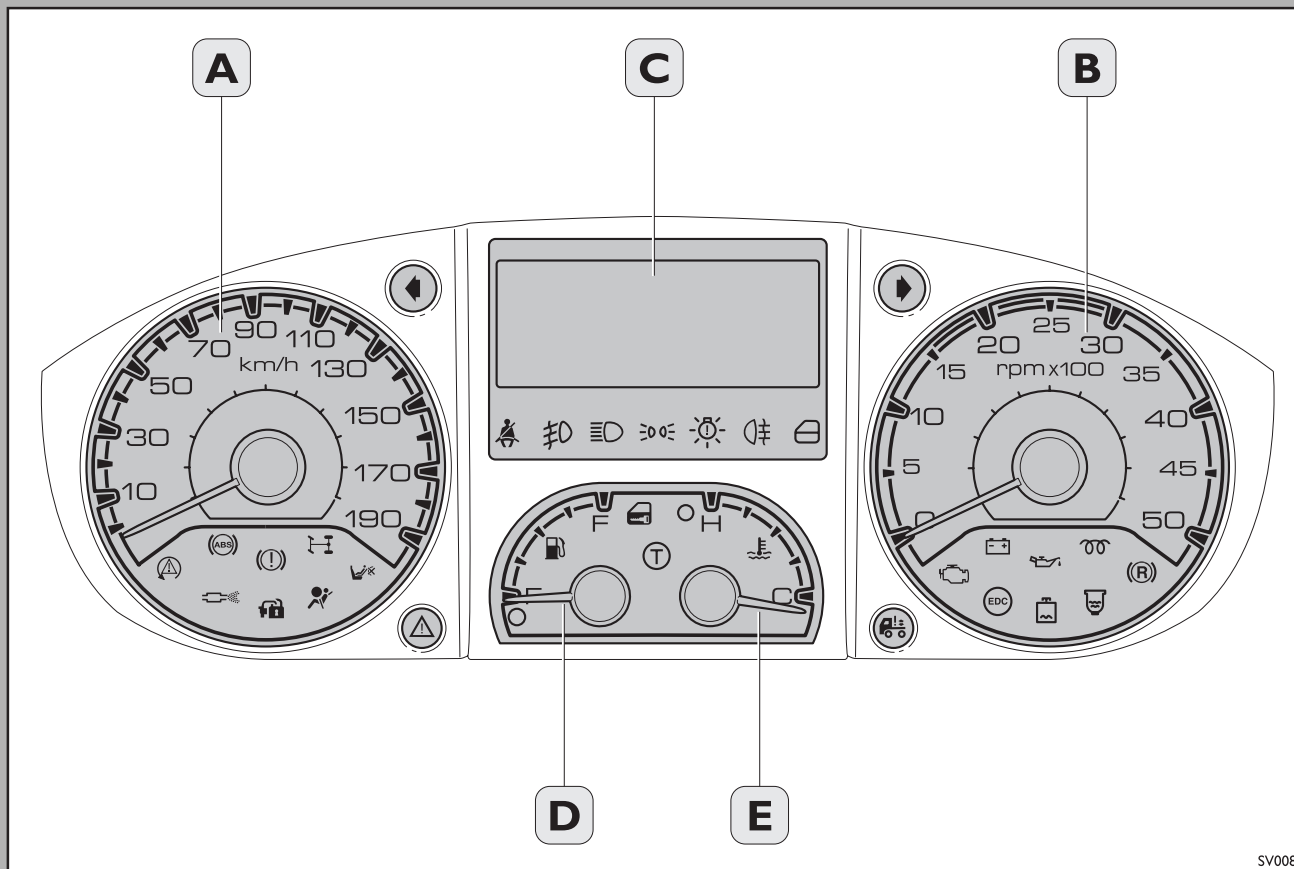

THE DRIVER'S POSITION

The operation of the warning lights highlighted with an asterisk is checked automatically each time the key is turned ON for the duration of a few seconds.

A= Speedometer / Tachograph

B = Rev counter

C = Multifunction display

D = Fuel level indicator with yellow reserve warning light

E = Engine coolant thermometer and red high temperature warning light





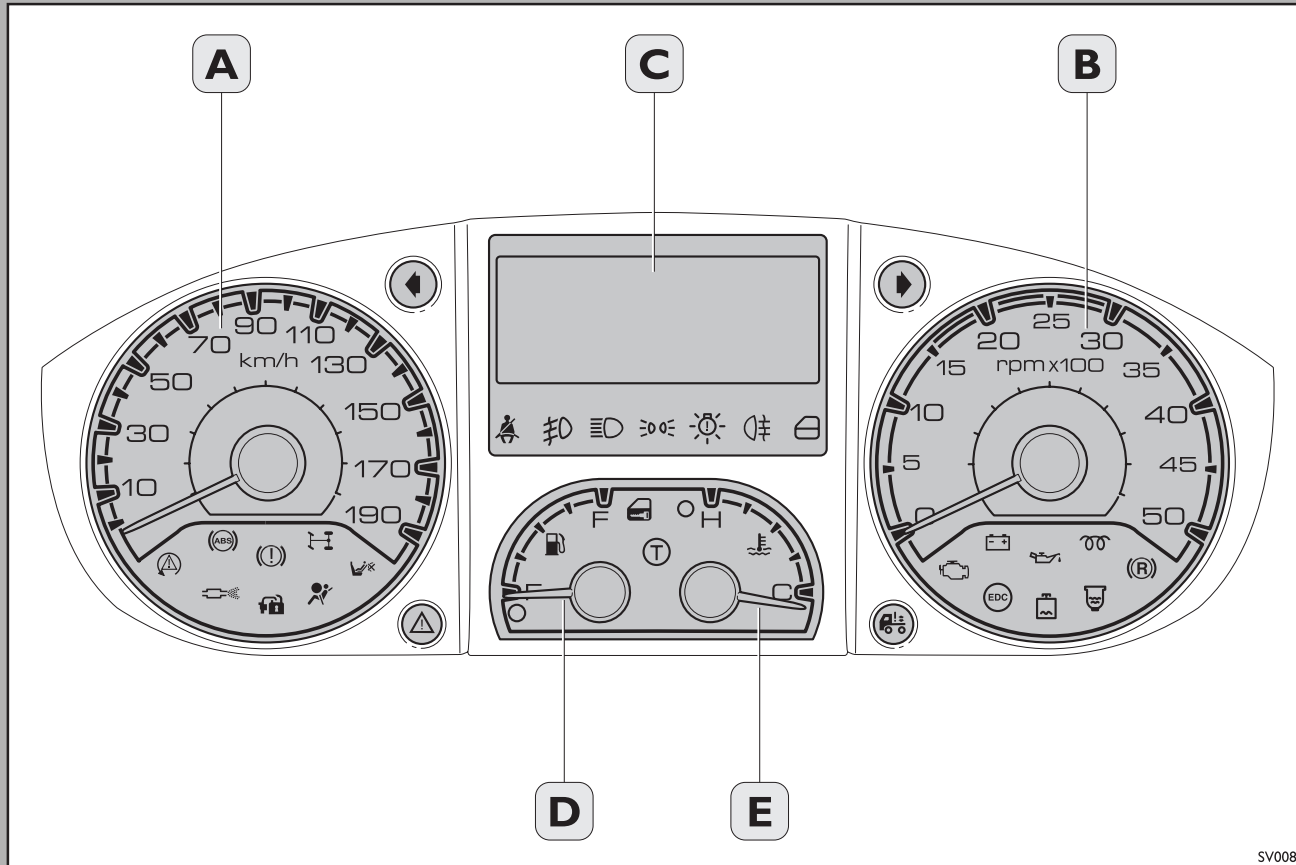



MEANING	IDEOGRAM	COLOUR
*ABS failure		yellow
DPF		yellow
*Brake failure/ EBD failure/ Parking brake on		red
*Vehicle protection system failure		yellow
Differential lock engaged		yellow
*AIRBAG MALFUNCTION		red
*Deactivation of passenger airbag		yellow
Left direction indicator		green
General malfunction		yellow
Driver's seat belt not fastened		red
FOG LAMPS		green

THE DRIVER'S POSITION



THE DRIVER'S POSITION

*The operation of the warning lights highlighted with an asterisk is checked automatically each time the key is turned ON for the duration of a few seconds.





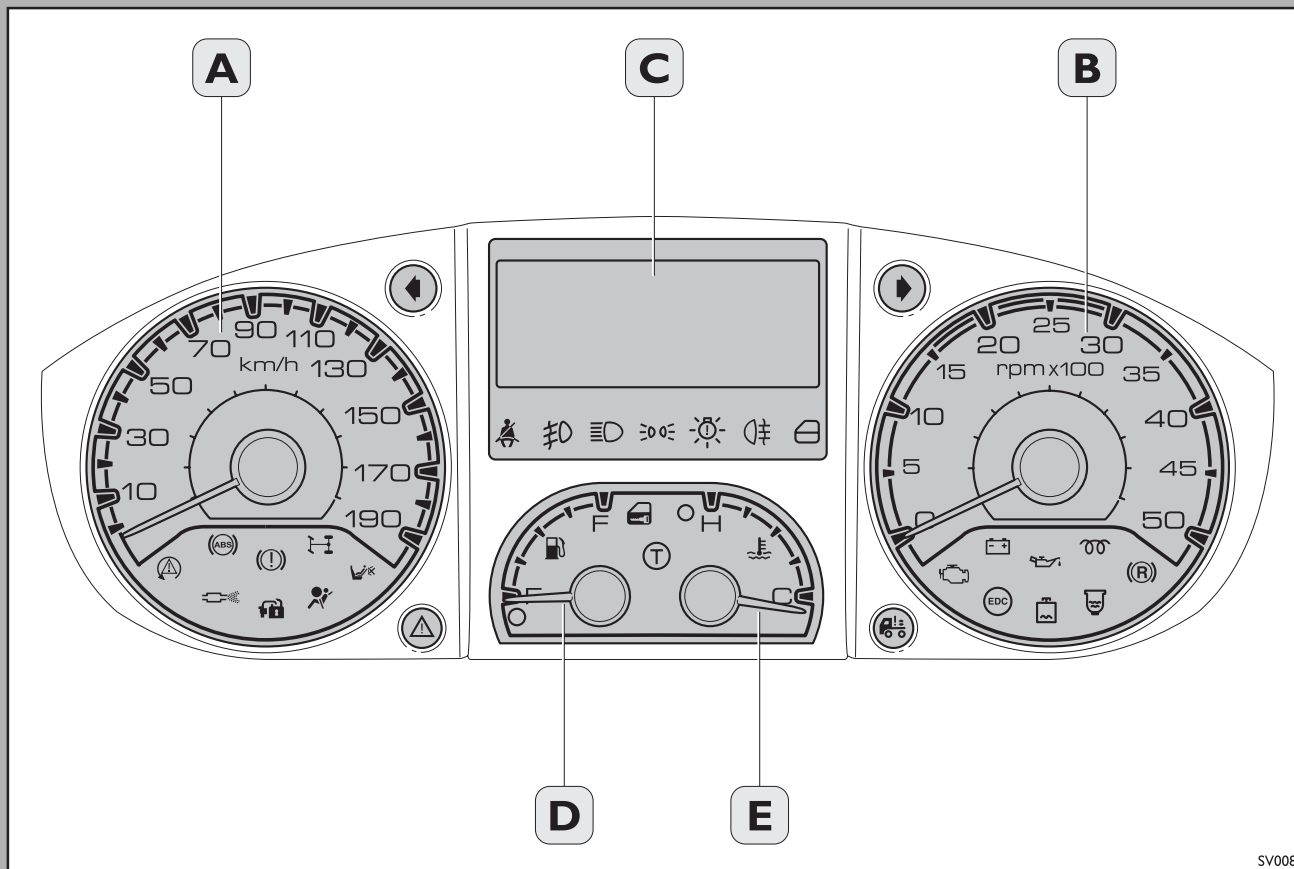

MEANING	IDEOGRAM	COLOUR
High beams		blue
Parking side lights		green
External lights failure		yellow
Rear fog lamps		yellow
Doors open		red
*External emergency handle locked with key		yellow
*Tachograph failure		yellow
Right direction indicator		green
*EOBD		yellow

THE DRIVER'S POSITION



THE DRIVER'S POSITION

*The operation of the warning lights highlighted with an asterisk is checked automatically each time the key is turned ON for the duration of a few seconds.

MEANING	IDEOGRAM	COLOUR
No battery charging		red
*EDC failure		red
*LOW ENGINE OIL PRESSURE		red
*Engine coolant level low		red
Glow plug pre-heating		yellow
*Water in fuel filter		yellow
*Retarder engaged		yellow

THE DRIVER'S POSITION

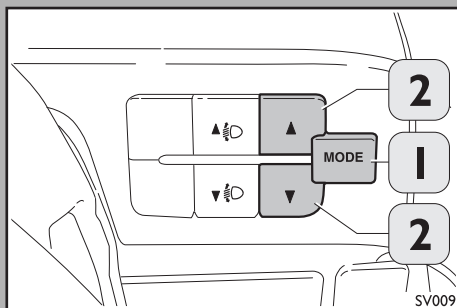

Menu keypad

Located on dashboard behind the right steering wheel lever.

1. MODE button short press (less than 1 second).

- With the vehicle stationary and complete menu shown on the display. With the vehicle moving, activating and displaying the menu in reduced form.

- Confirm selected function.

- Confirm modification/adjustment made and return to the main menu screen.

1. MODE button long press (more than 1 second).

- Save confirmed changes with short press and return to the main screen .

2. Increase/decrease buttons “+/-”:

- Select functions on the menu.

- Select/adjust functions on the menu.

Adjustment of the functions (e.g. clock) occurs in increasingly shorter steps, depending on how long the button is pressed.

THE DRIVER'S POSITION

Control method

The control modes differ from each other according to the nature of the selected item.

A) SELECT AN ITEM FROM THE MAIN MENU WITHOUT SUBMENU

- By briefly pressing (less than one second) the "MODE" button you can select the setting of the main menu that you wish to change.
- Using the "+" or "-" buttons (single presses) it is possible to select the new setting.
- By briefly pressing (less than one second) the "MODE" button you can save the setting and at the same time go back to the same item of the main menu previously selected.

B) SELECT AN ITEM FROM THE MAIN MENU WITH SUBMENU

- By briefly pressing (less than one second) the "MODE" button you can view the first item of the submenu.
- By using the "+" or "-" buttons (single presses) you can scroll through all the items of the submenu.
- By briefly pressing (less than one second) the "MODE" button you can select the displayed item of the submenu and access the setting menu.
- By using the "+" or "-" buttons (single presses) you can select the new setting of this submenu item.
- By briefly pressing (less than one second) the "MODE" button you can save the setting and at the same time go back to the same item of the main menu previously selected.

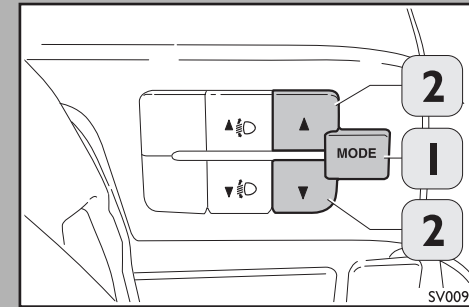

THE DRIVER'S POSITION

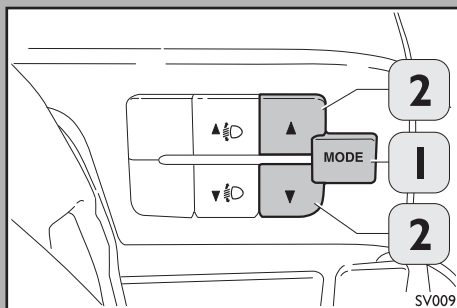

C) SELECTION OF DATE AND CLOCK SETTING FUNCTIONS

- By briefly pressing (less than one second) the "MODE" button you can select the first figure to change (hours/minutes or year/month/day)
- Using the "+" or "-" buttons (single presses) it is possible to select the new setting
- By briefly pressing (less than one second) the "MODE" button you can save the setting and at the same time move on to the next item of the setting menu and, if this is the last one, you go back to the same item of the main menu previously selected.

D) PASSENGER AIRBAG ON/OFF

- By briefly pressing (less than one second) the "MODE" button you can decide whether to turn the passenger airbag on/off
- Using the "+" or "-" buttons (single presses) it is possible to select the new setting
- By briefly pressing the "+" or "-" buttons (less than one second) confirmation of the setting is requested; the confirmation request must occur even if the original setting was not changed.
- By using the "+" or "-" buttons (single presses) you can select the new setting (selection confirmed/not confirmed)
- If confirmed by briefly pressing (less than one second) the "MODE" button, a confirmation message is displayed, after which you go back to the same item of the main menu previously selected.
- If not confirmed (by briefly pressing the "MODE" button for less than one second), you go back to the same item of the main menu previously selected, without displaying the confirmation message.

THE DRIVER'S POSITION

Notes:

By pressing the MODE button (for more than one second):

- If you are at the level of the main menu you exit the menu environment, if you are at any other level you go to the level of the main menu.
- Only the changes already saved by the user are saved.

The menu environment is on a time setting; at the end of the time, without any other operations being carried out, only the changes already saved by the user are saved.

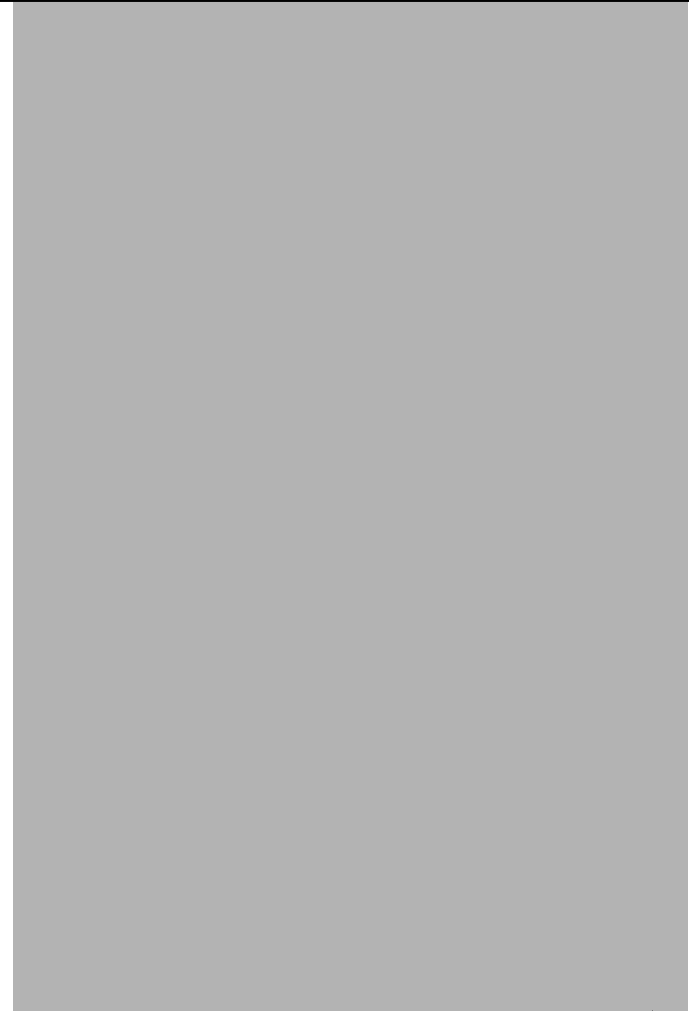

THE DRIVER'S POSITION

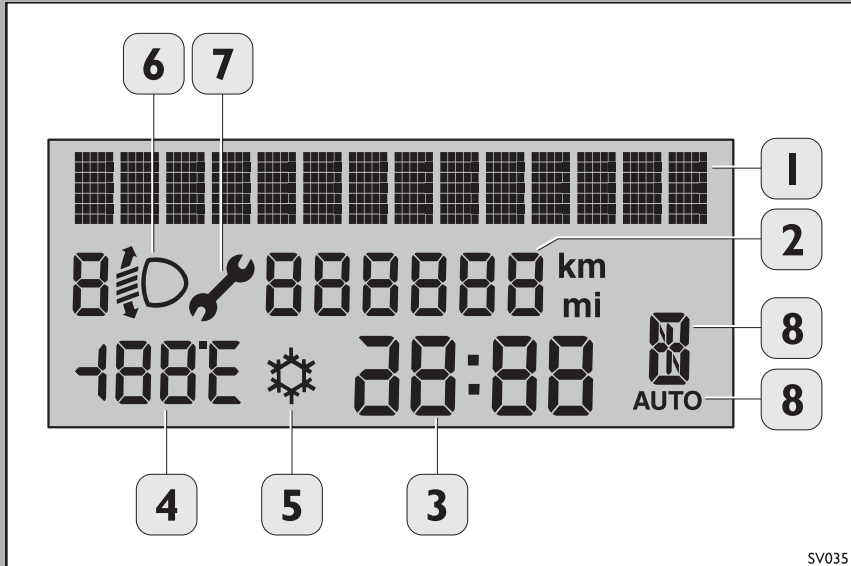

COMFORT version display

1. Line for trip computer data display; menu with the respective setting/adjustment messages; Service/failure/warning/functions activation messages.
2. total odometer.
3. Clock.
4. Outside temperature.
5. "Snow" symbol - danger of ice.
6. Headlight trim corrector.
7. "Service" spanner symbol.
8. Automatic transmission information (if provided).

Scheduled maintenance function display

At the end of a partial threshold, the display will appear as described on page 57.

The driver can interrupt the display by pressing (long press) the MODE button. Display can occur in km/miles, hours of operation or in days depending on the type of scheduled maintenance operation.

This function must be considered a reminder for the driver, for the main maintenance times.

For the validity of the warranty and to ensure the lasting efficiency of the vehicle, carefully comply with the IVECO scheduled maintenance plan, given inside this publication.

THE DRIVER'S POSITION

SV016

Safety belts not fastened signalling display

The "seat belts" warning light signals the driver's seat belt has not been fastened and stays on fixed after starting the engine if the seat belt has not been fastened.

In addition, when the first of the following events occurs:

- a. Time elapsed equal to 180 seconds and vehicle speed detected greater than 10 km/h.
- b. Vehicle speed higher than 25 km/h.
- c. Distance travelled greater than 500 metres.

The warning light blinks and a buzzer sounds until the seat belt is fastened.

THE DRIVER'S POSITION

Viewing messages on the display

The messages on the display are divided into four different classes:

- High priority faults (8 viewing cycles).
- Low priority faults (4 viewing cycles).
- Information (4 viewing cycles).
- Feedback (1 viewing cycle).
- Controlled by control unit (while the cause remains).

The longer messages are divided in rows of 14 characters on the display for complete viewing.

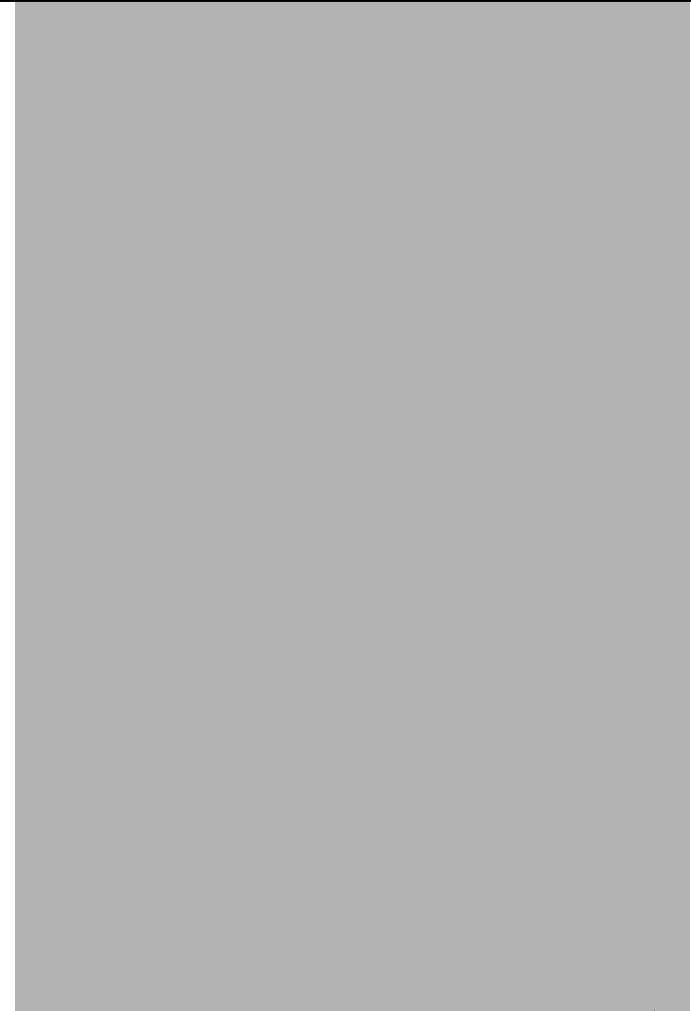

COMFORT version menu layout - Vehicle starting (key ON)

1. With the key ON, with none of the above conditions, the standard screen is displayed. The warnings for low engine and automatic transmission oil pressure immediately stop the standard screen during the check phase. If a phone call arrives, it is displayed at any time and remains displayed until the call is accepted or refused. The warning for doors open with vehicle in motion stops the key ON status and is displayed until the MODE button is pressed.

2. Low engine oil pressure signalling.

3. Telephone call signalling.

4. Doors open signalling.

5. Instrument illumination.

6. ASR.

7. Audio.

8. MENU.

9. Trip.

10. Audio repetition, menu and trip are only available 2 seconds after turning the key ON.

THE DRIVER'S POSITION

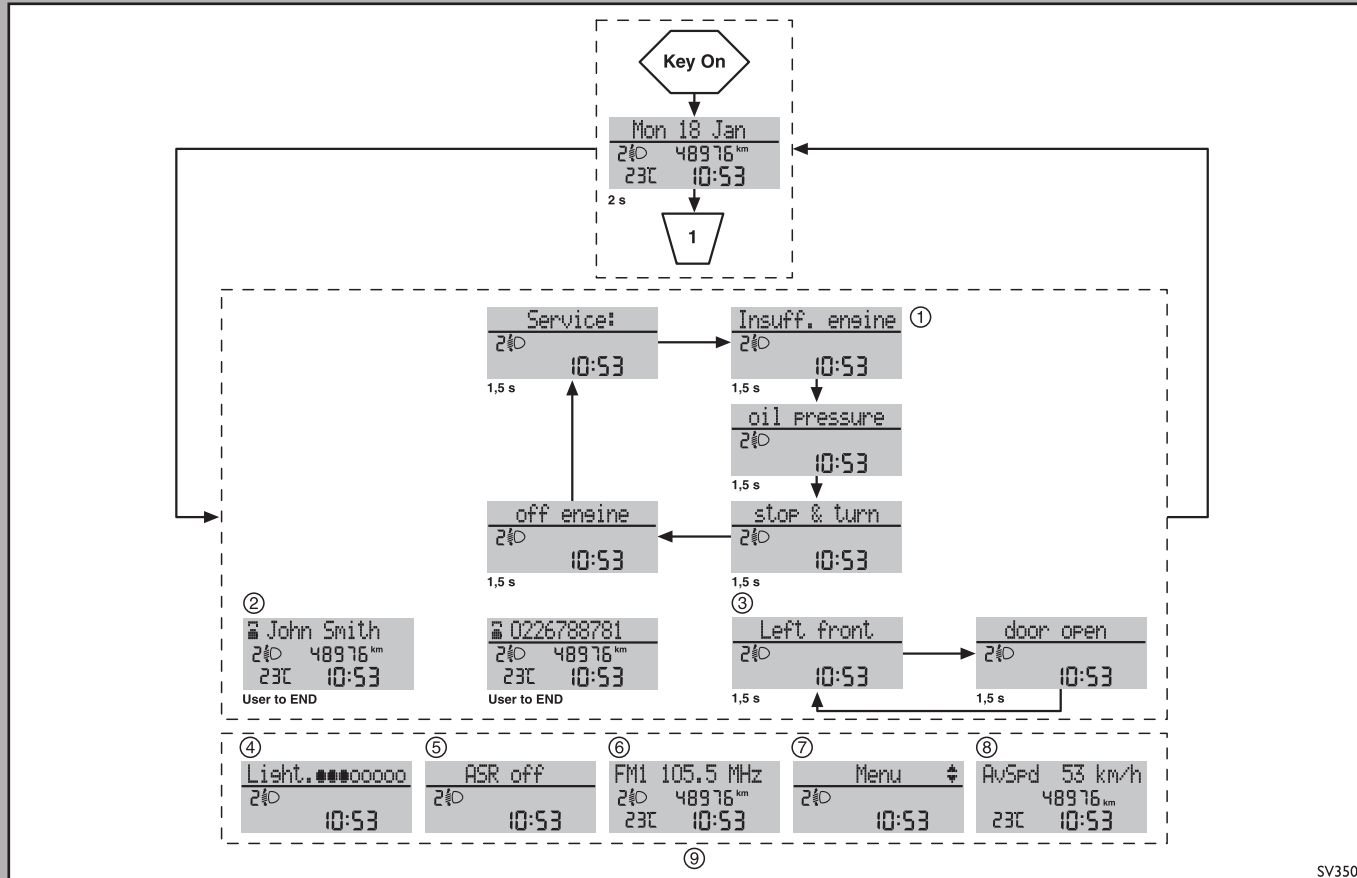

THE DRIVER'S POSITION

COMFORT version menu layout - Vehicle starting (key ON)

1. Low engine oil pressure signalling.
2. Telephone call signalling.
3. Doors open signalling.
4. Instrument illumination.
5. ASR.
6. Audio RPT.
7. Setup menu.
8. Trip.
9. Audio repetition, menu and trip are available only 2 seconds after turning the key ON.

THE DRIVER'S POSITION

COMFORT version menu layout - Vehicle starting (key ON)

- Scheduled maintenance signalling occurs just once after turning the key ON, when the value of km/hours/days to the service is below a new threshold.
- The scheduled maintenance (due) warning is displayed each time the key is turned ON (but only for the 1000 km/20 hours/20 days following the first time due).

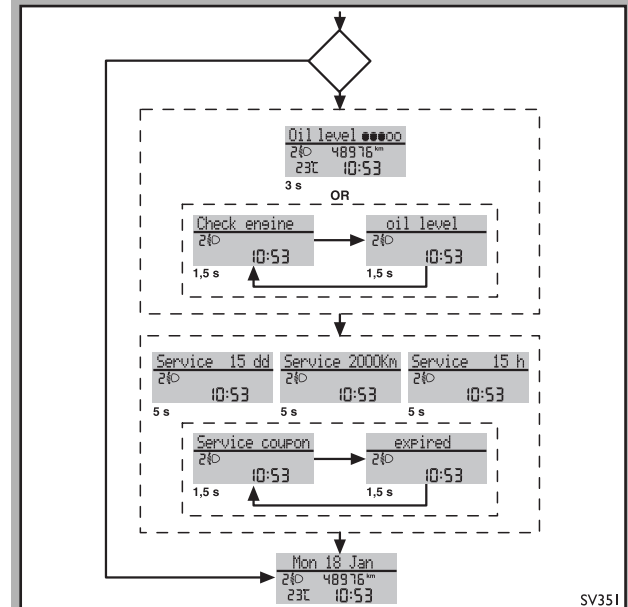

THE DRIVER'S POSITION

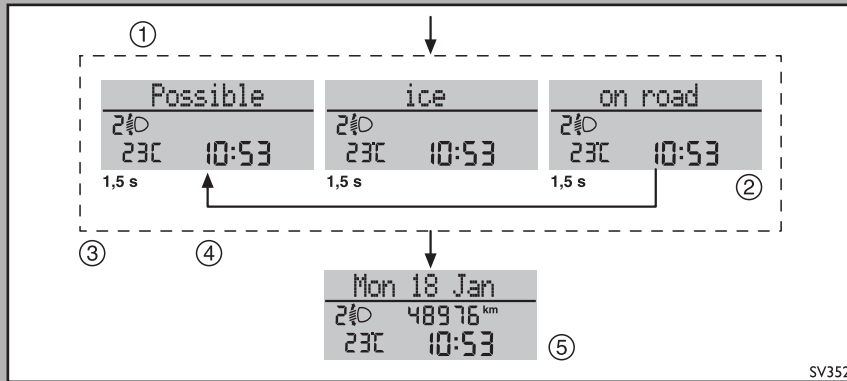

COMFORT version menu layout - Ice danger signalling

1. Temperature below 3°C.
2. The odometer does not appear during the warning.
3. During the warning the temperature indication will blink.
4. Four cycles, or MODE button to exit.
5. The odometer returns after the warning.

THE DRIVER'S POSITION

COMFORT version menu layout - Exceeding speed limit

1. Odometer and temperature do not appear during the display.
 2. Four cycles, or MODE button to exit.
 3. Odometer and temperature are displayed after the warning.
 4. The warning disappears when 5 km under the activation threshold.
- Temperature and odometer signalling remain after the warning.

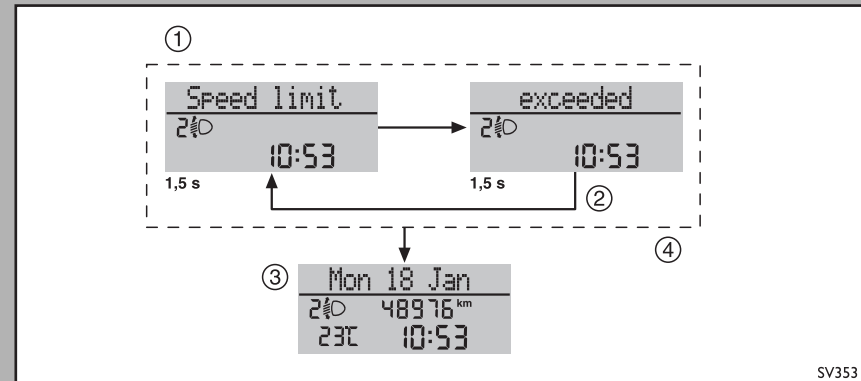

SV353

THE DRIVER'S POSITION

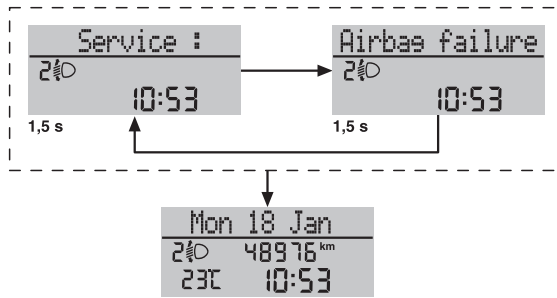

SV354

COMFORT version menu layout - Airbag failure

- The MODE button ends the display.
- Odometer and temperature are displayed after the warning.

THE DRIVER'S POSITION

COMFORT version menu layout - Door/hatch opening signalling (screen present only on vans)

1. Only one door open?
2. Four cycles, or MODE button to exit.
3. The cycle takes place among all the doors open, four cycles for each door open.
4. Temperature and odometer signalling returns after the warning.

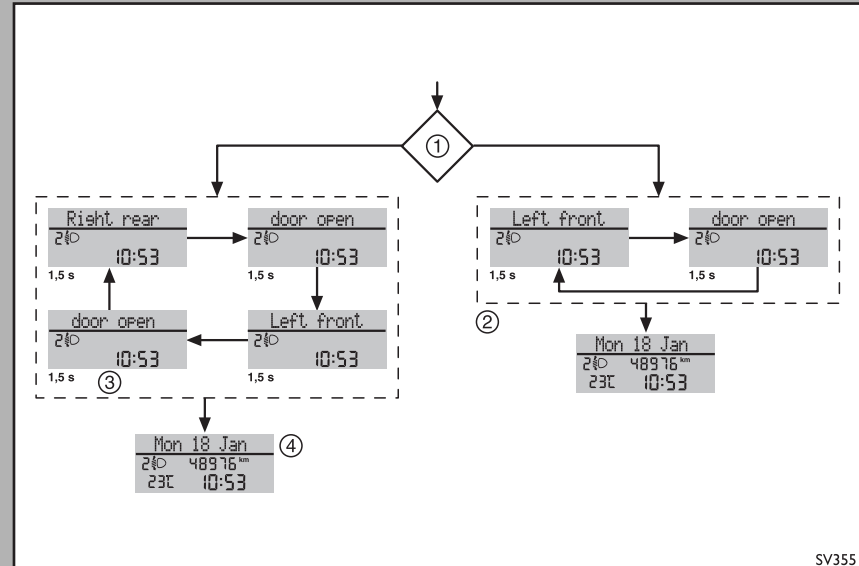

SV355

THE DRIVER'S POSITION

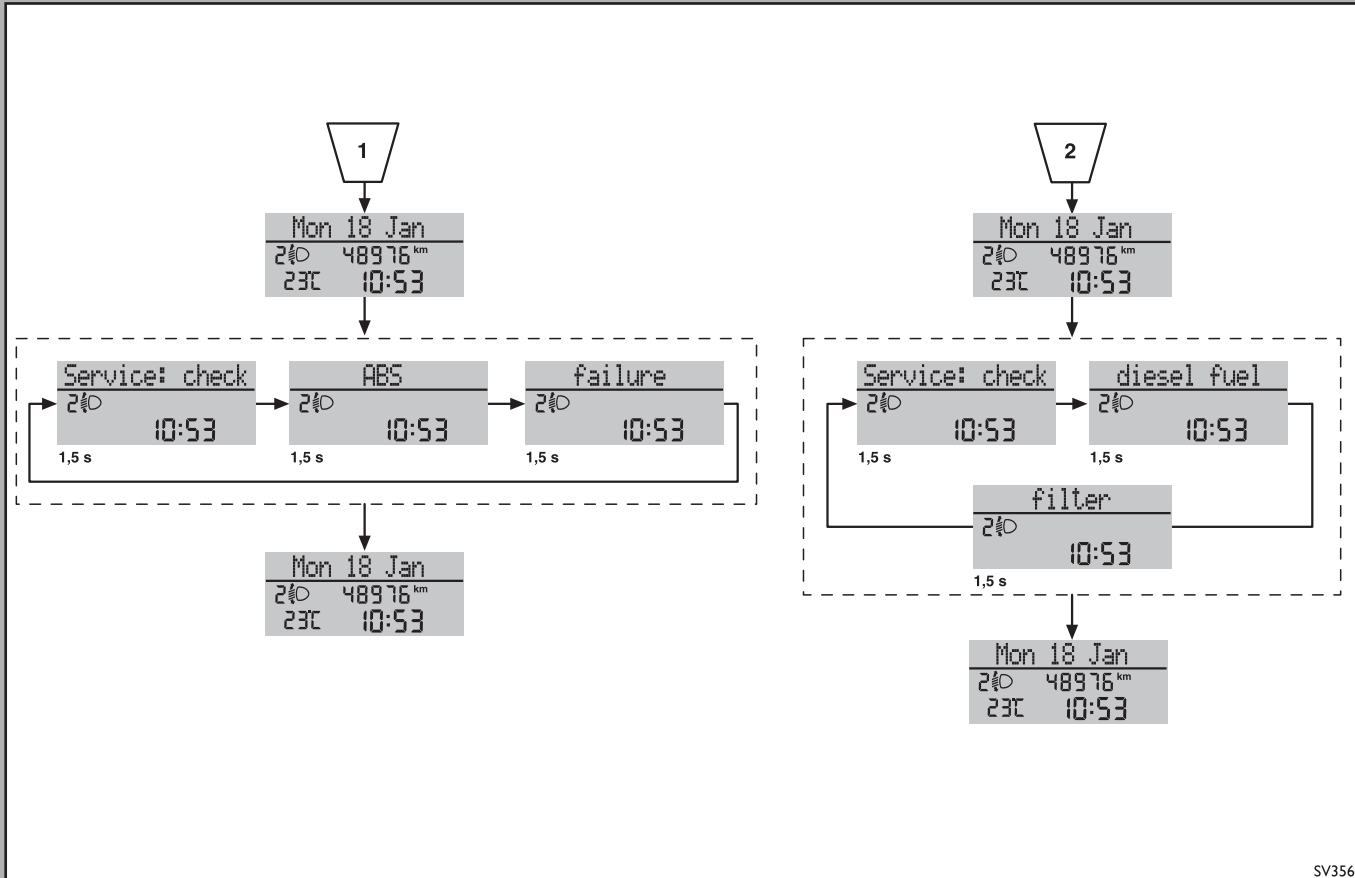

THE DRIVER'S POSITION

COMFORT version menu layout - Alarm signalling

- Temperature and odometer signalling returns after the warning.

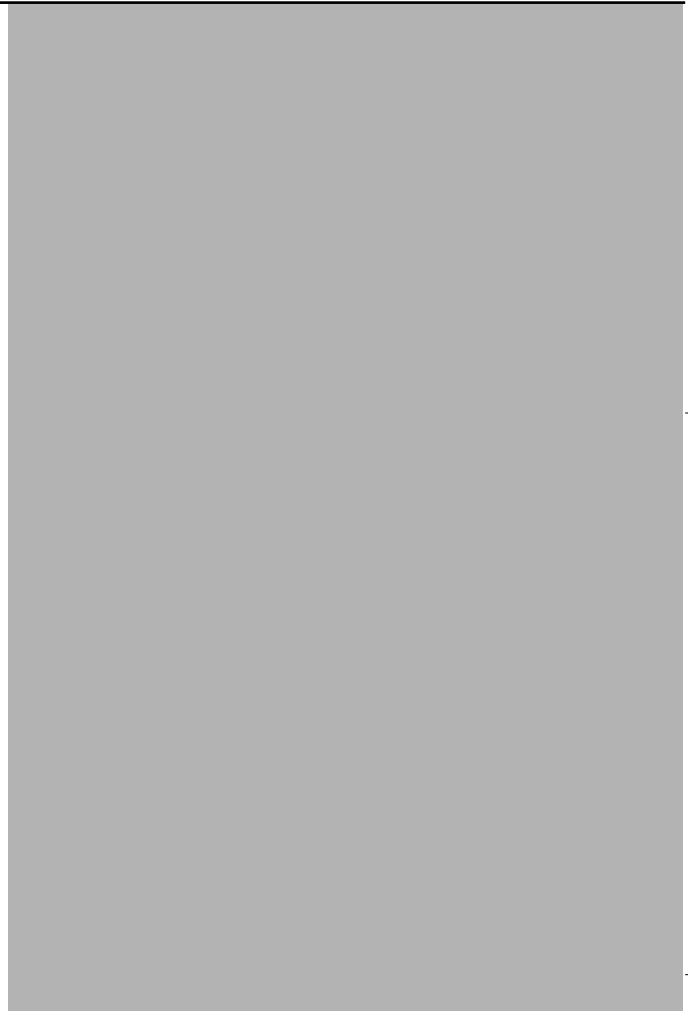

THE DRIVER'S POSITION

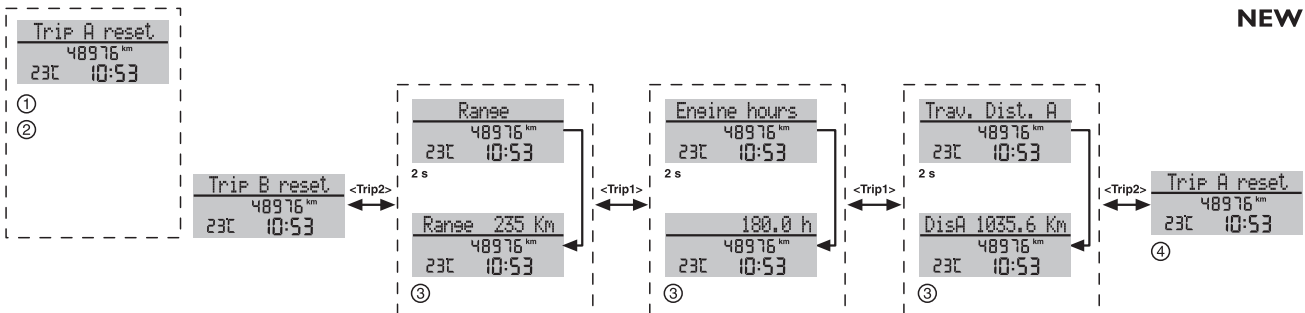

COMFORT version menu layout - Trip Computer (I)

- Display of Trip Computer information not permitted with existing warnings.
- Trip 1 = Trip button pressed for less than two seconds.
- Trip 2 = Trip button pressed for more than two seconds.
- Mode 1 = Mode button pressed for less than two seconds.

1. Reset all the parameters except for autonomy and instant consumption.

2. **Note:** Resetting trip A also resets the values of trip B, but not vice versa.

3. A single cycle and then the second screen remains displayed.

4. Two seconds later return to the previous screen.

Note: The distance in km menu is not available for CNG versions.

Note: During the initial phase of particulate trap regeneration, the consumption cannot be measured and the display shows "start antipollution filter regeneration".

THE DRIVER'S POSITION

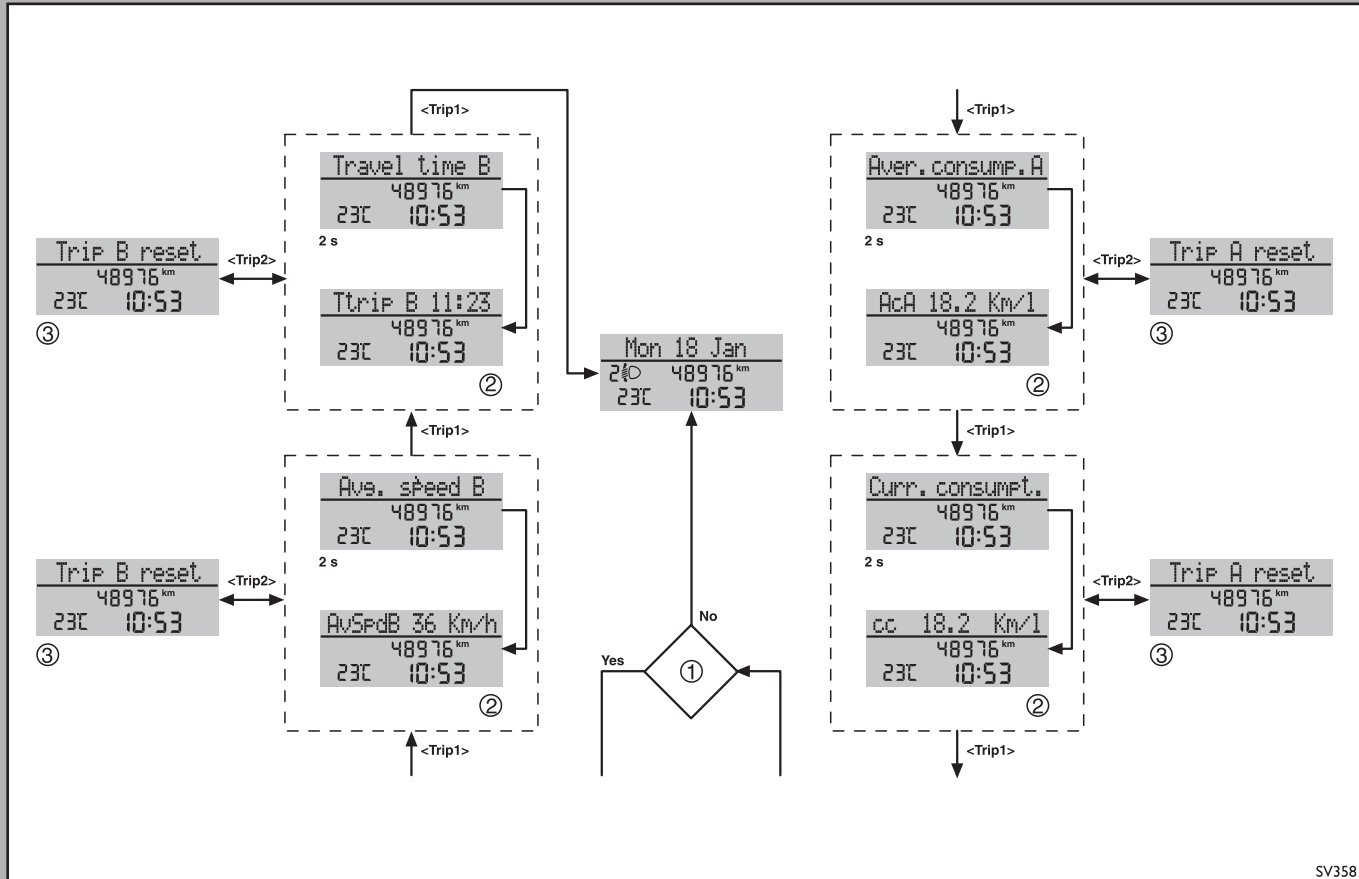

THE DRIVER'S POSITION

COMFORT version menu layout - Trip Computer (2)

1. Trip B present?
2. A single cycle and then the second screen remains displayed.
3. Two seconds later return to the previous screen.

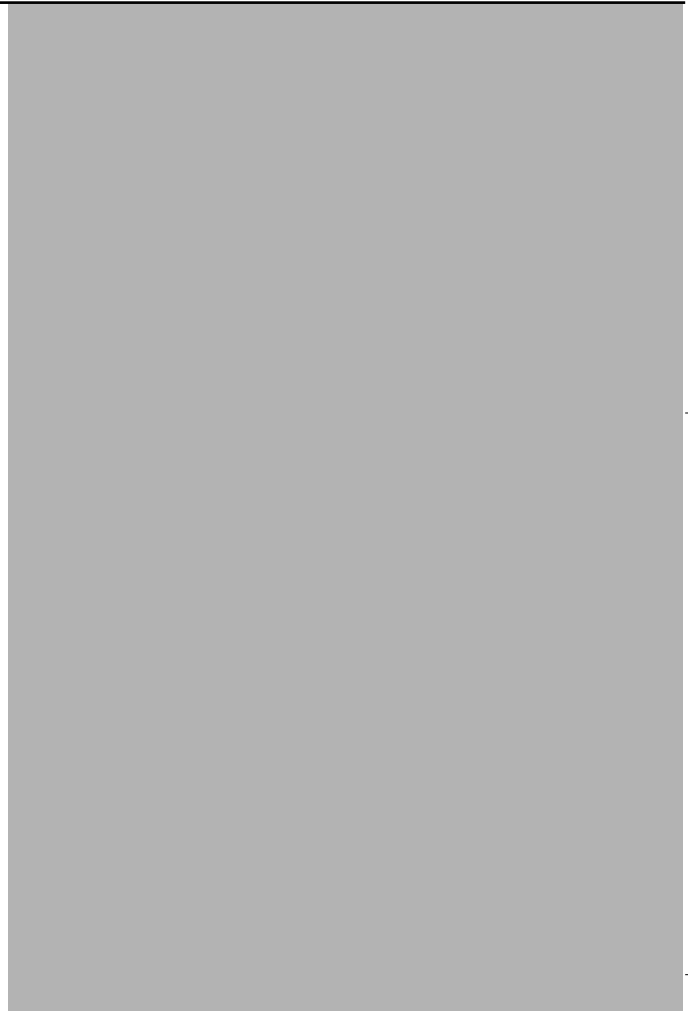

THE DRIVER'S POSITION

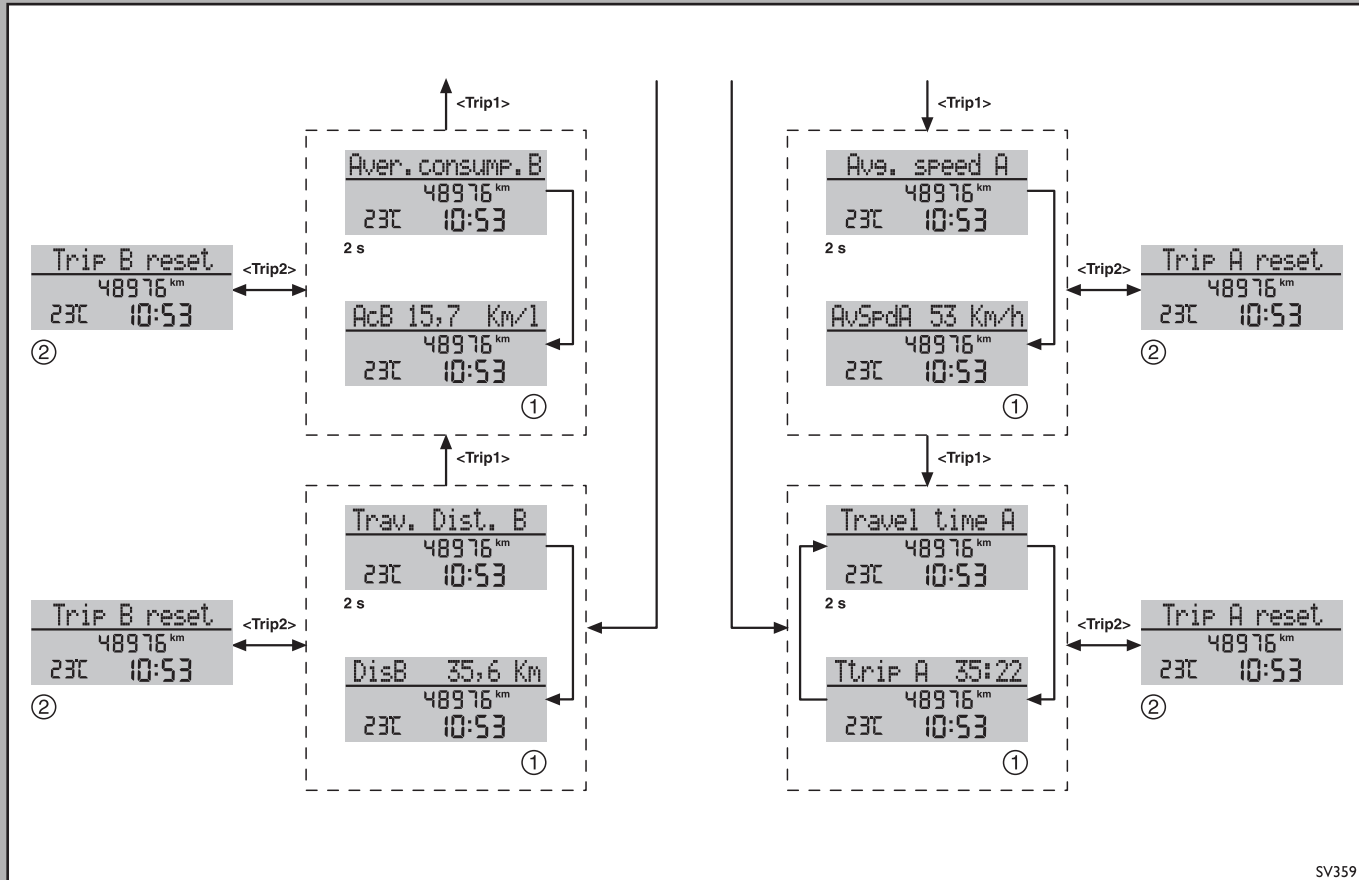

THE DRIVER'S POSITION

COMFORT version menu layout - Trip Computer (3)

1. A single cycle and then the second screen remains displayed.
2. Two seconds later return to the previous screen.

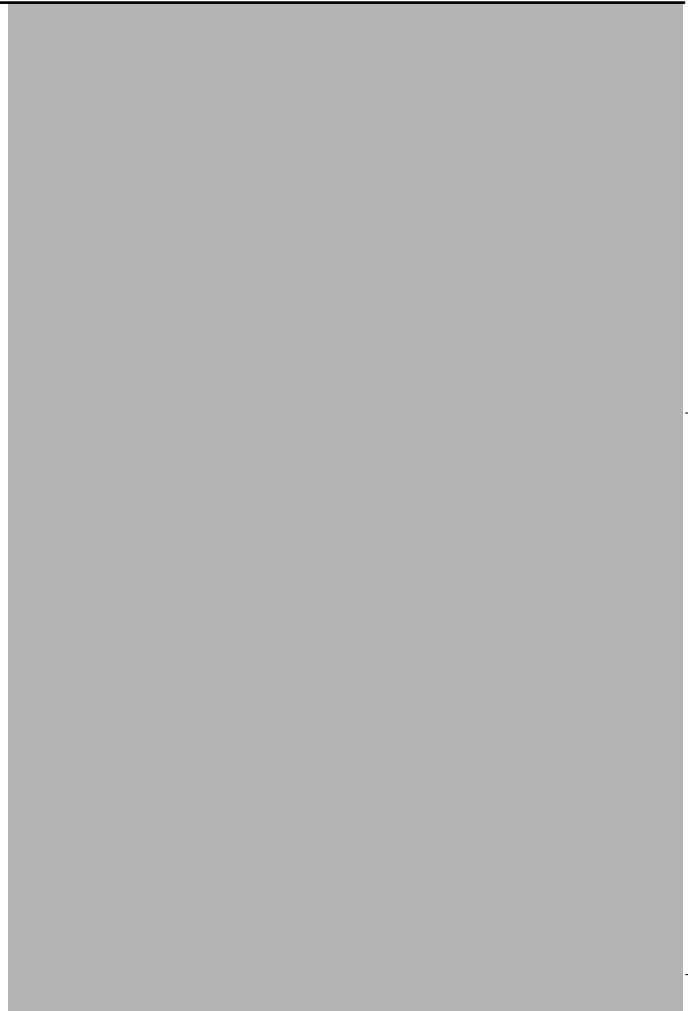

THE DRIVER'S POSITION

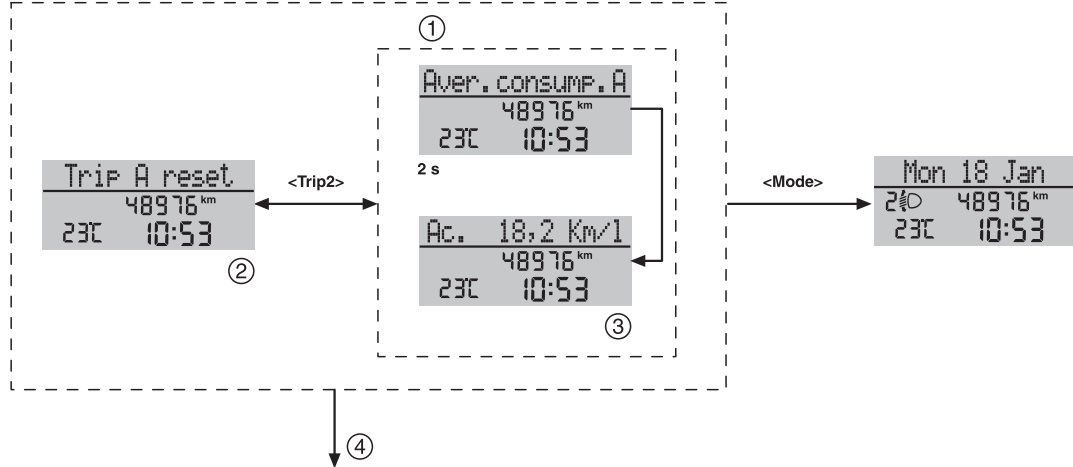

THE DRIVER'S POSITION

COMFORT version menu layout - Trip Computer (4)

1. Generic Trip screen.
2. Two seconds later return to the previous screen.
3. A single cycle and then the second screen remains displayed.
4. Warning requiring display.

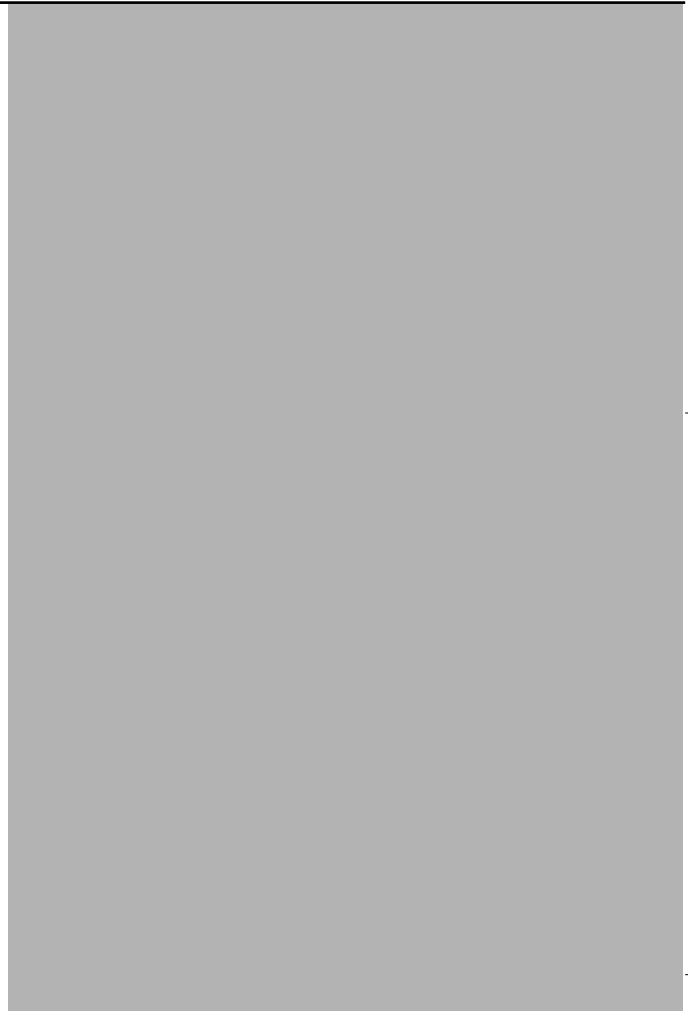

THE DRIVER'S POSITION

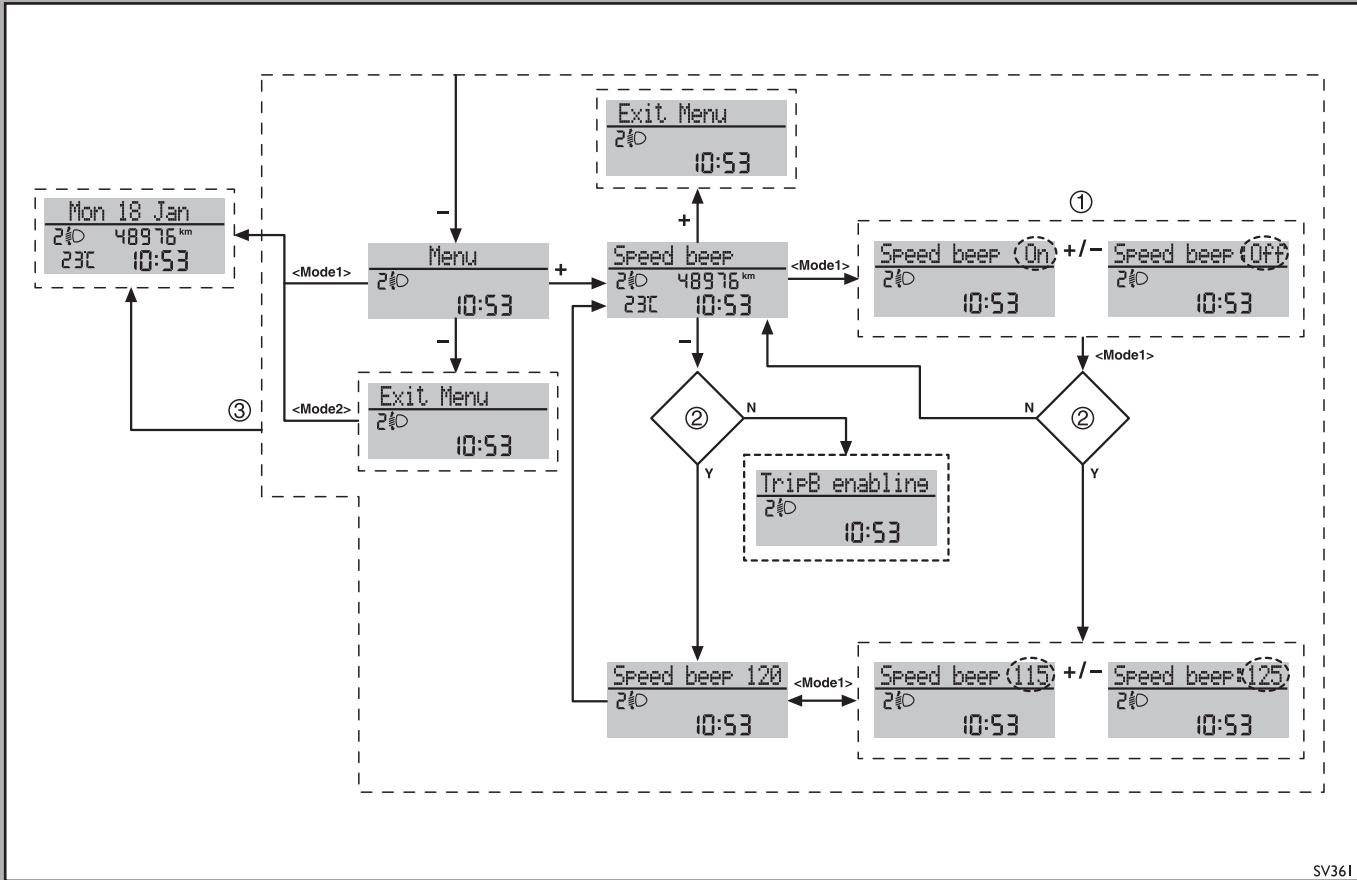

COMFORT version menu layout - General menu (I)

1. The buttons + and - both switch from ON to OFF and vice versa. Mode I confirm the set value. ON/OFF will blink.
2. Speed limiter ON?
3. Mode 2 or end of time period with no action.
 - Mode 1 = Mode button pressed for less than two seconds. Mode 2 = Mode button pressed for more than two seconds.

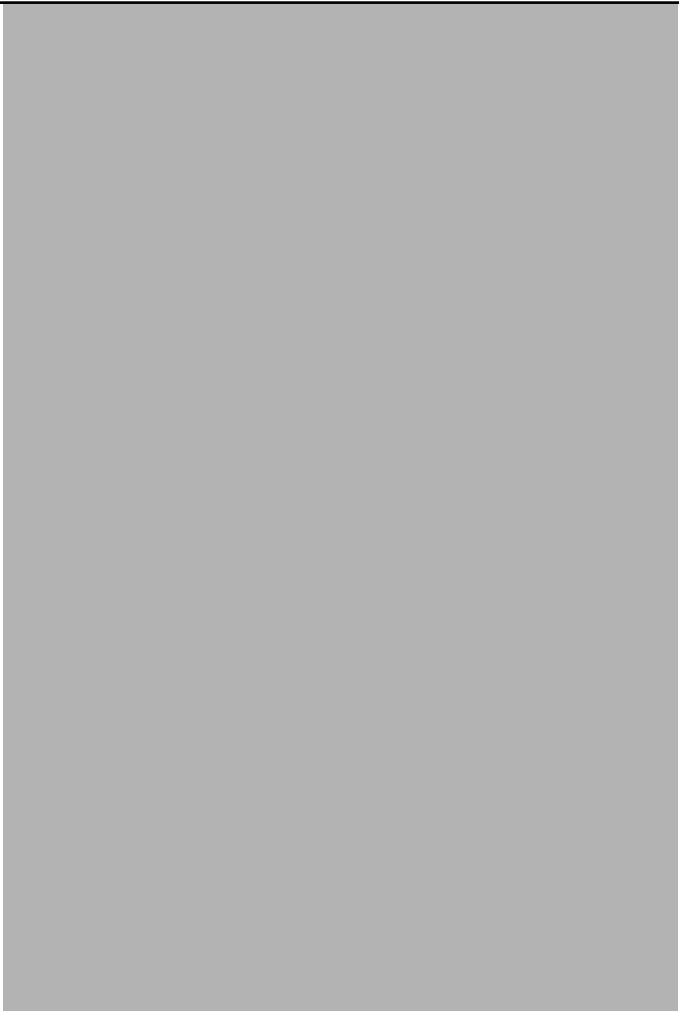

THE DRIVER'S POSITION

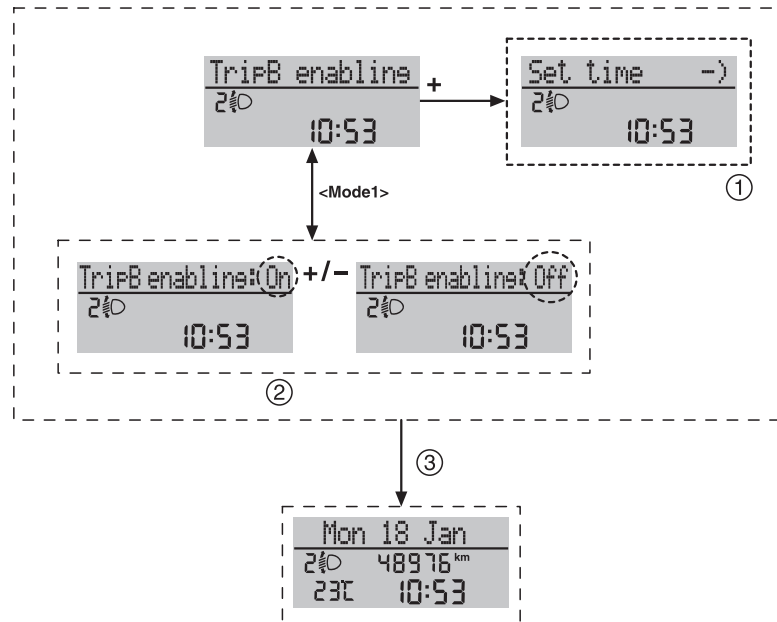

COMFORT version menu layout - General menu (2)

1. Clock setting menu
2. The buttons + and - both switch from ON to OFF and vice versa.
Mode 1 confirm the set value.
ON/OFF will blink.
3. Mode 2 or end of time period with no action.

THE DRIVER'S POSITION

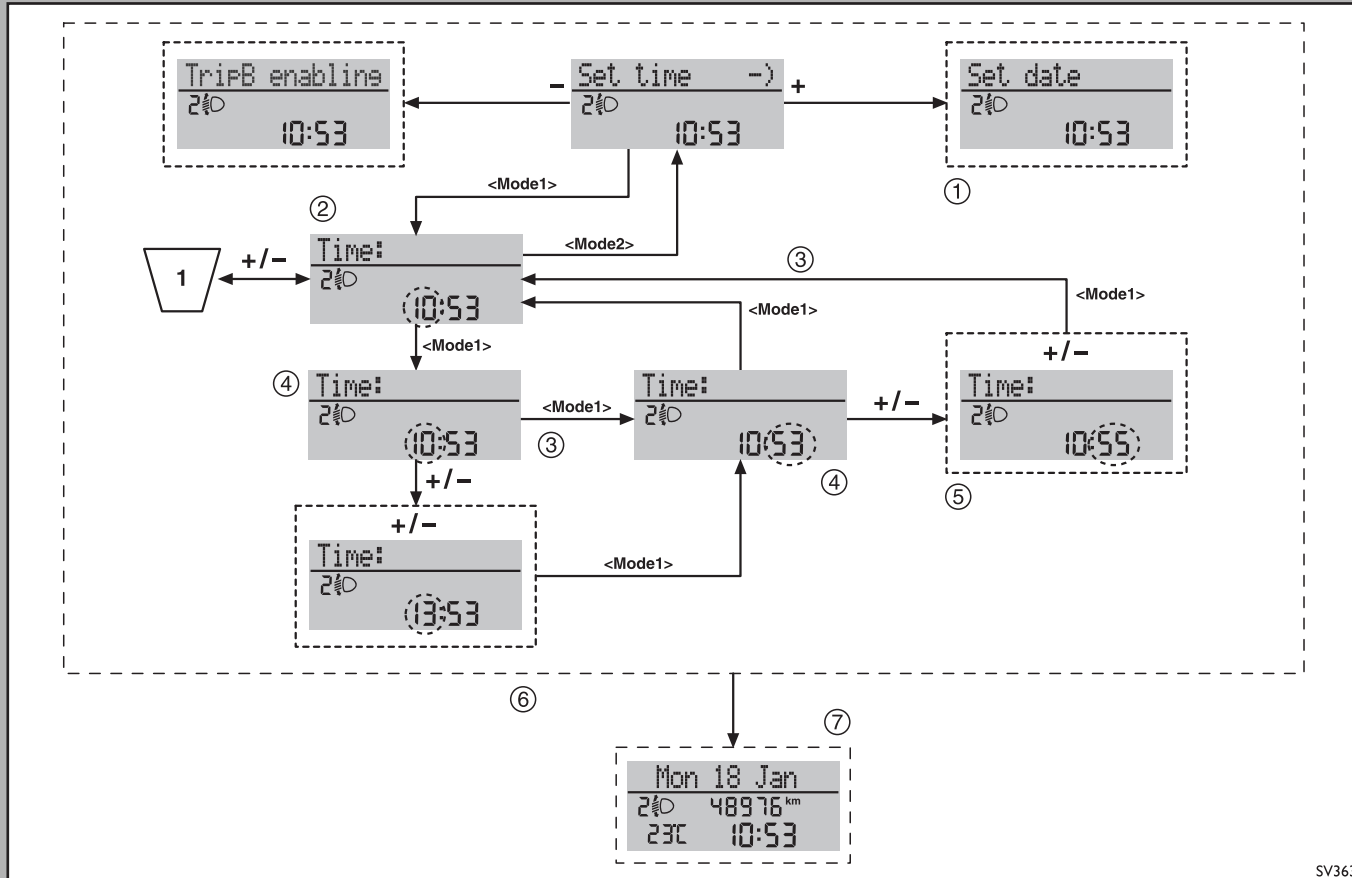

COMFORT version menu layout - General menu (3)

1. Date setting menu
2. Other submenus
3. Mode 1 confirm the set value.
4. The hour indication will blink.
5. The + and - buttons both make the minutes change. Mode 1 confirm the set value.
The minutes indication will blink.
6. The + and - buttons both make the hour change.
Mode 1 confirm the set value.
The hour indication will blink.
7. Mode 2 or end of time period with no action.

THE DRIVER'S POSITION

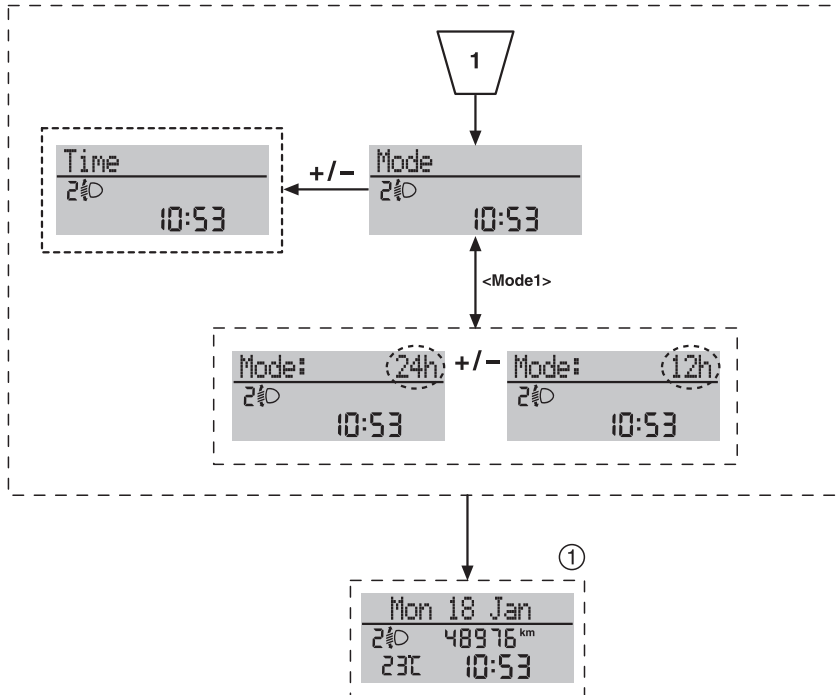

COMFORT version menu layout - General menu (4)

- The buttons + and - both switch from 12h to 24h and vice versa. Mode 1 confirm the set value. 12h/24h will blink.
1. Mode 2 or end of time period with no action.

THE DRIVER'S POSITION

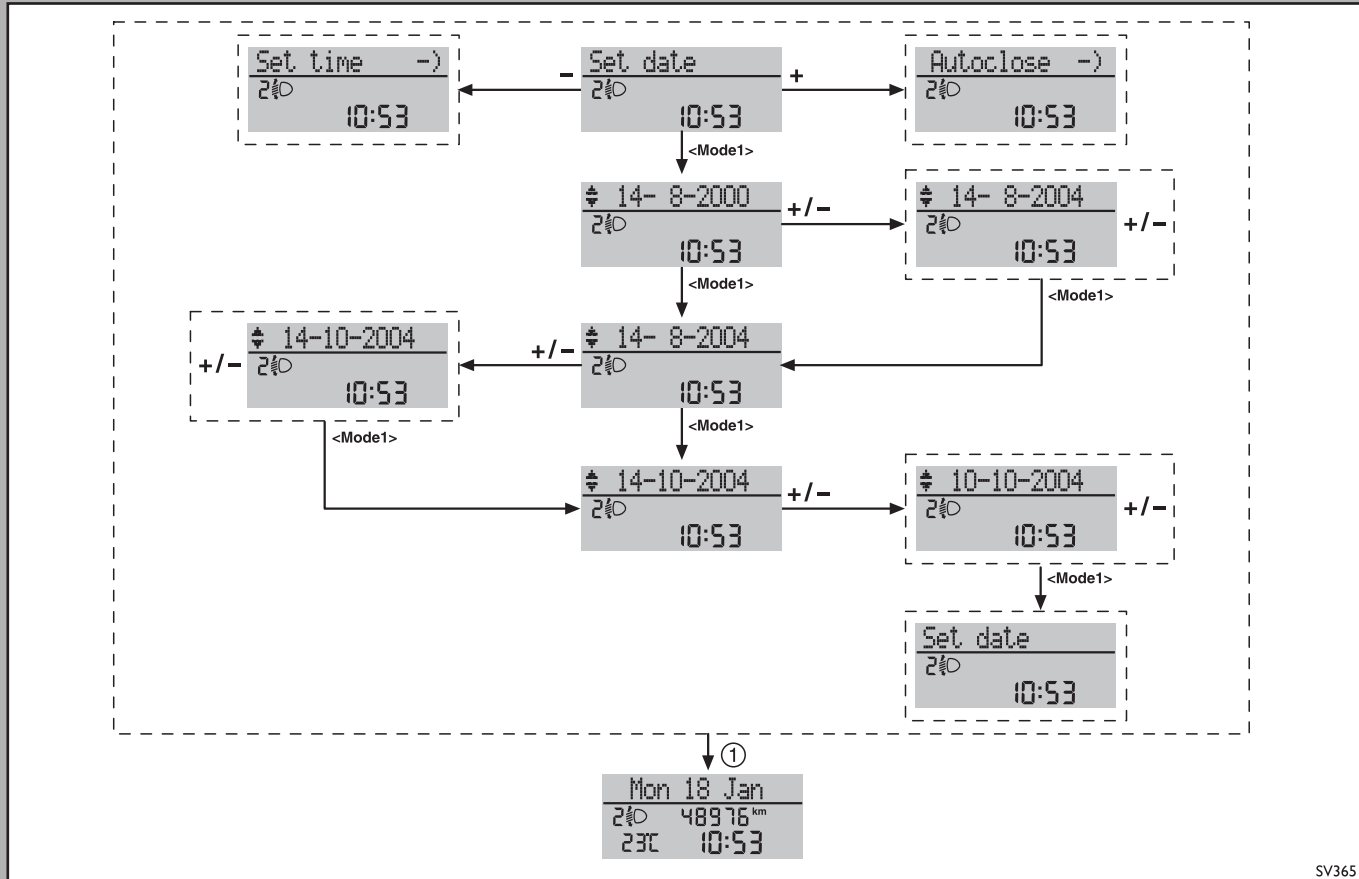

THE DRIVER'S POSITION

COMFORT version menu layout - General menu (5)

- Depending on the value blinking, the buttons + and - both make the year, month or day change. Mode 1 confirm the set value.
I. Mode 2 or end of time period with no action.

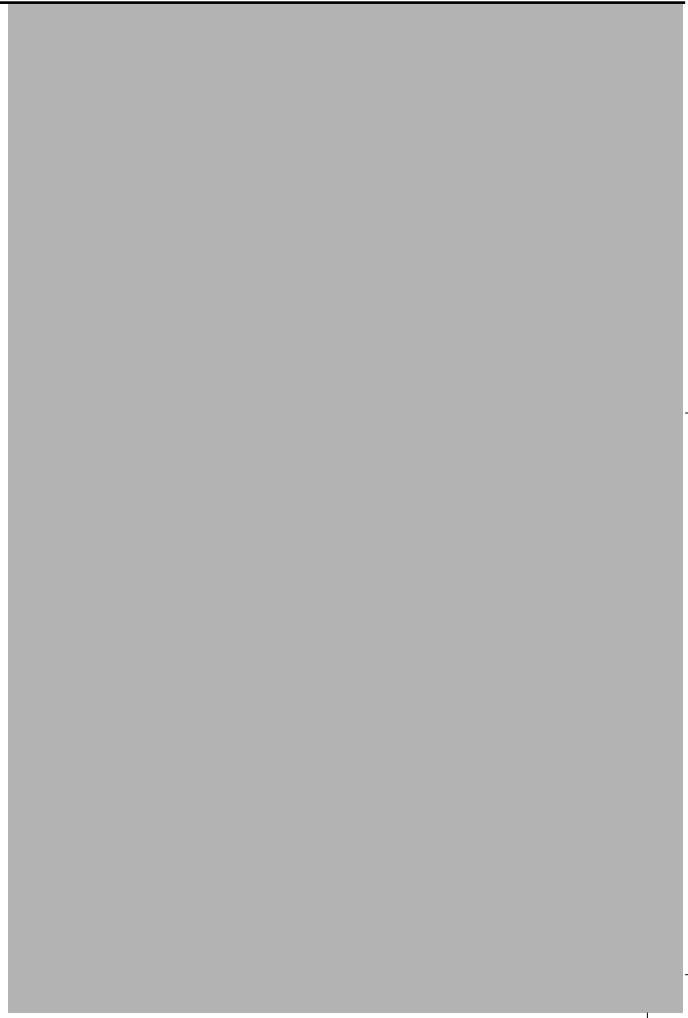

THE DRIVER'S POSITION

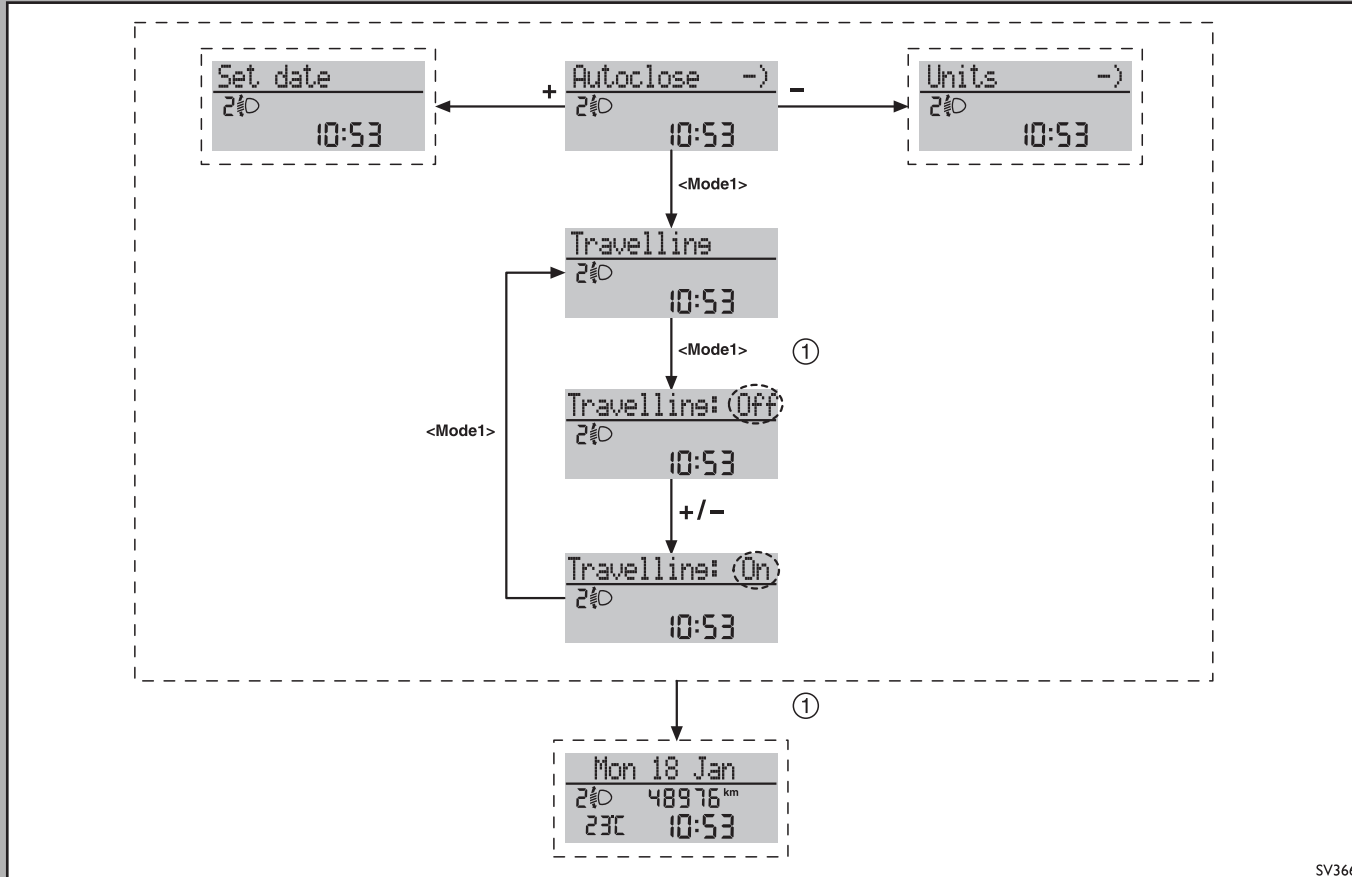

THE DRIVER'S POSITION

COMFORT version menu layout - General menu (6)

- The buttons + and - both switch from ON to OFF and vice versa. Mode 1 confirm the set value. ON/OFF will blink.
1. Mode 2 or end of time period with no action.

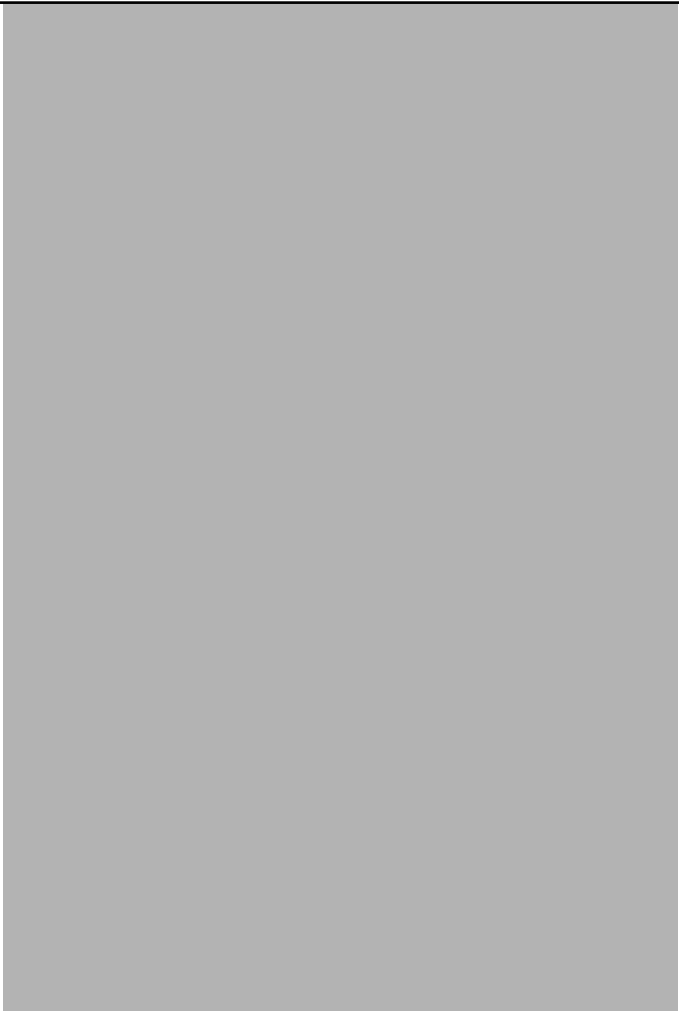

THE DRIVER'S POSITION

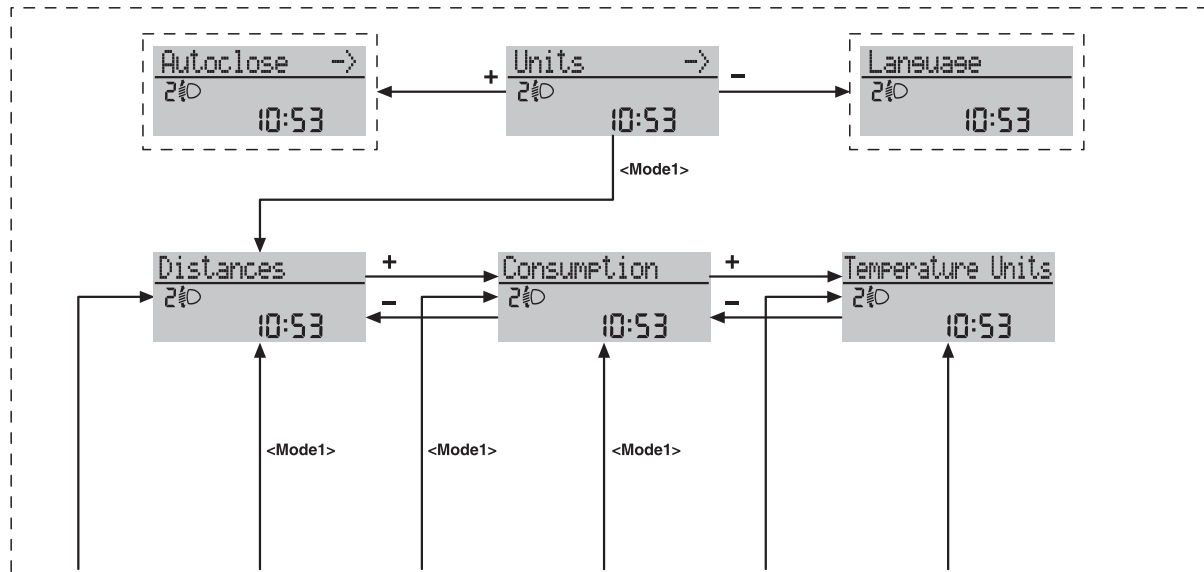

THE DRIVER'S POSITION

COMFORT version menu layout - General menu (7)

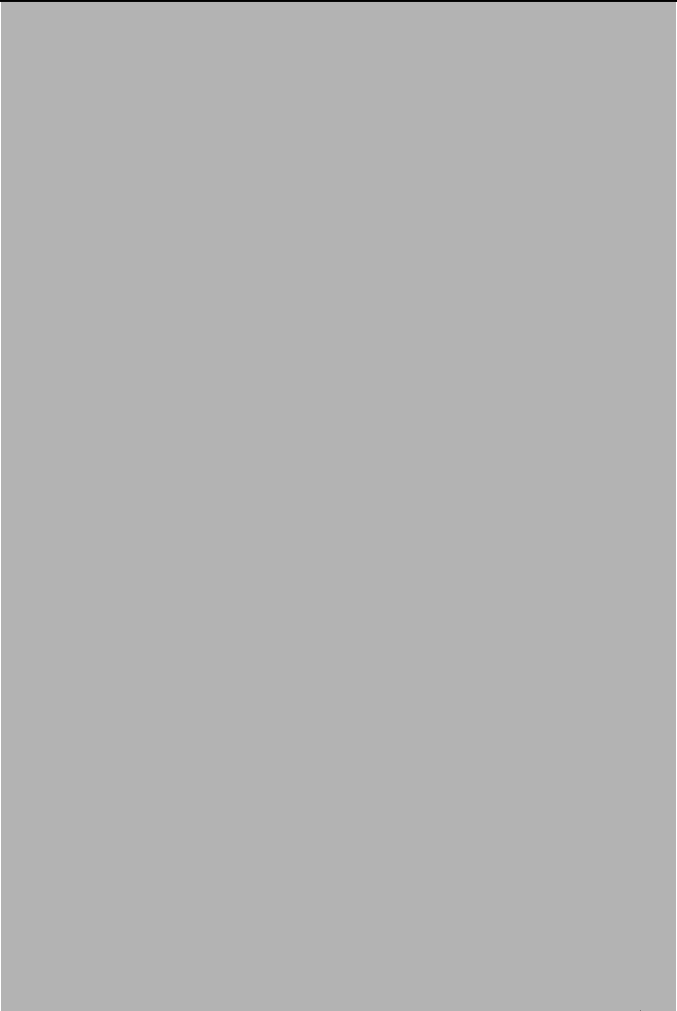

THE DRIVER'S POSITION

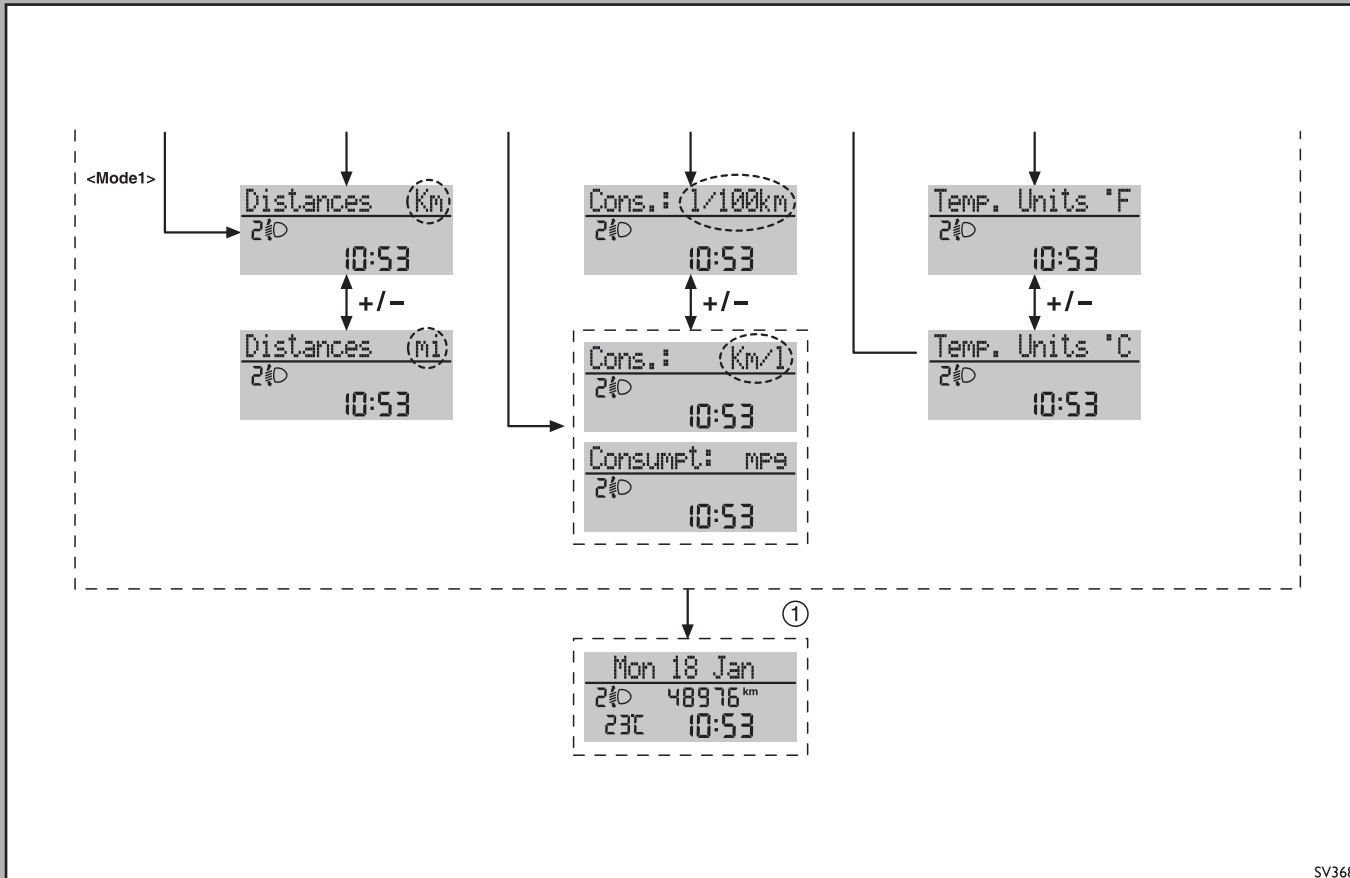

COMFORT version menu layout - General menu (8)

- The buttons + and - both switch from km to miles and vice versa. Mode 1 confirm the set value.
1. Mode 2 or end of time period with no action.

THE DRIVER'S POSITION

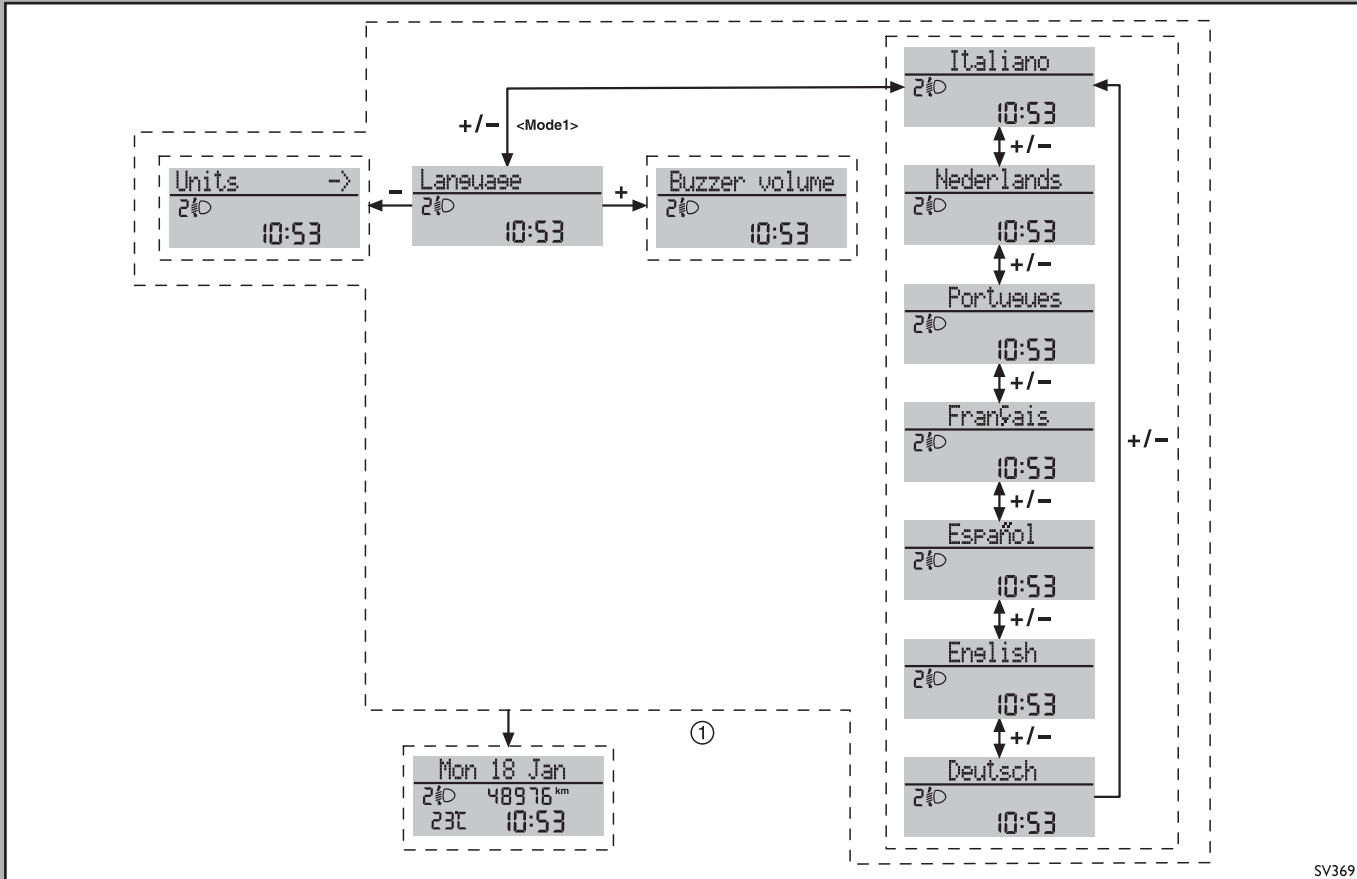

THE DRIVER'S POSITION

COMFORT version menu layout - General menu (9)

- Use the + and - buttons to cyclically scroll the list of selectable languages.
Mode 1 confirm the set value. The language indication will blink.
I. Mode 2 or end of time period with no action.



THE DRIVER'S POSITION

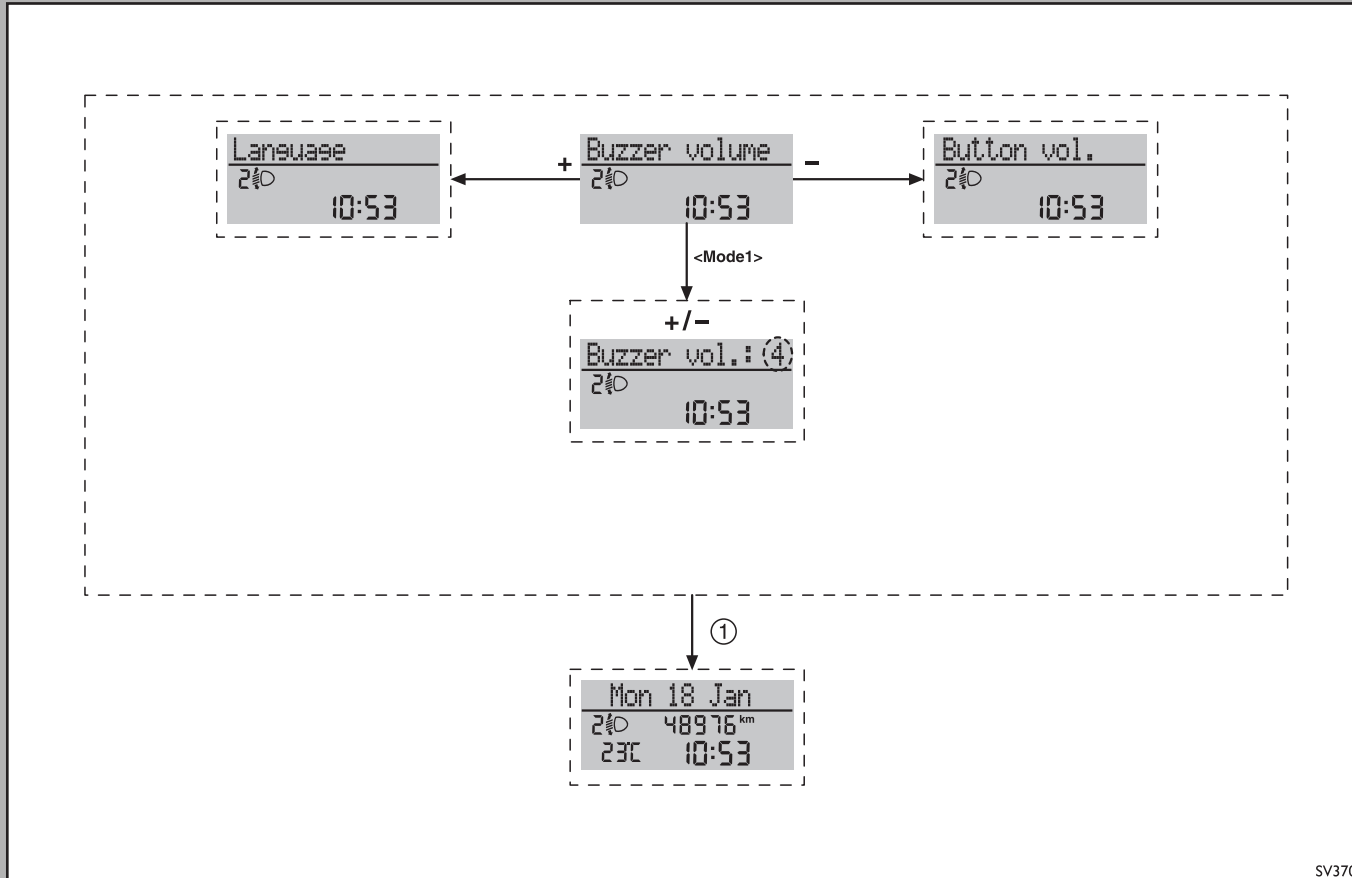

THE DRIVER'S POSITION**COMFORT version menu layout - General menu (10)**

- Use the + and - buttons to select the values from 0 to 7 (not cyclic).
Mode 1 confirm the set value. On reaching the maximum value that can be set, pressing + has no effect. On reaching the minimum value, pressing - has no effect. The indication blinks and during the adjustment the buzzer will beep with volume equal to the adjustment.
- 1. Mode 2 or end of time period with no action.

THE DRIVER'S POSITION

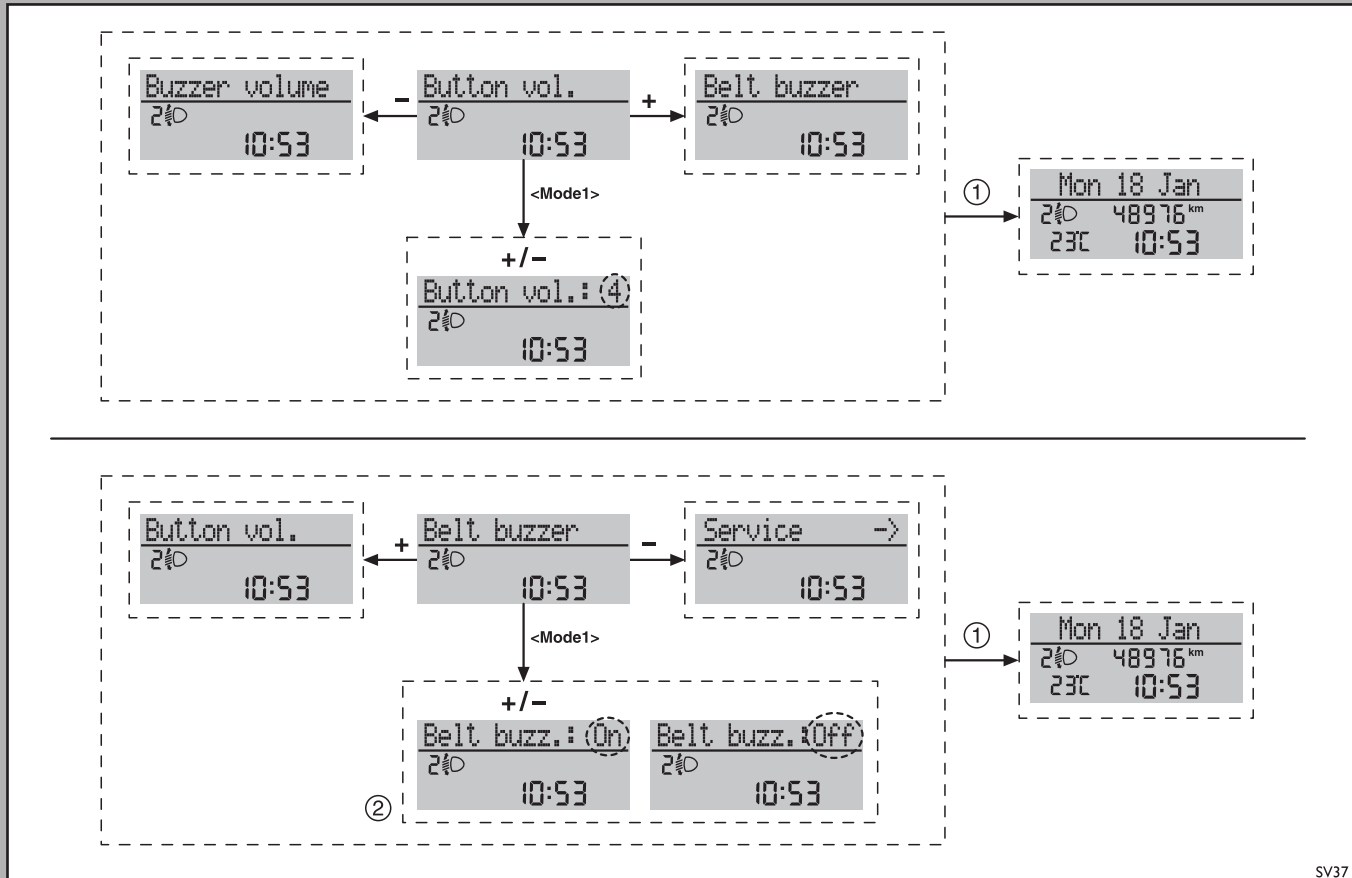

THE DRIVER'S POSITION

COMFORT version menu layout - General menu (11)

- Use the + and - buttons to select the values from 0 to 7 (not cyclic).
Mode 1 confirm the set value. On reaching the maximum value that can be set, pressing + has no effect. On reaching the minimum value, pressing - has no effect. The indication blinks and during the adjustment the buzzer will beep with volume equal to the adjustment.
1. Mode 2 or end of time period with no action.
- The buttons + and - both switch from ON to OFF and vice versa. Mode 1 confirm the set value. ON/OFF will blink.
2. This item of the menu only appears if the belt buzzer is disabled by the Service Network.



THE DRIVER'S POSITION

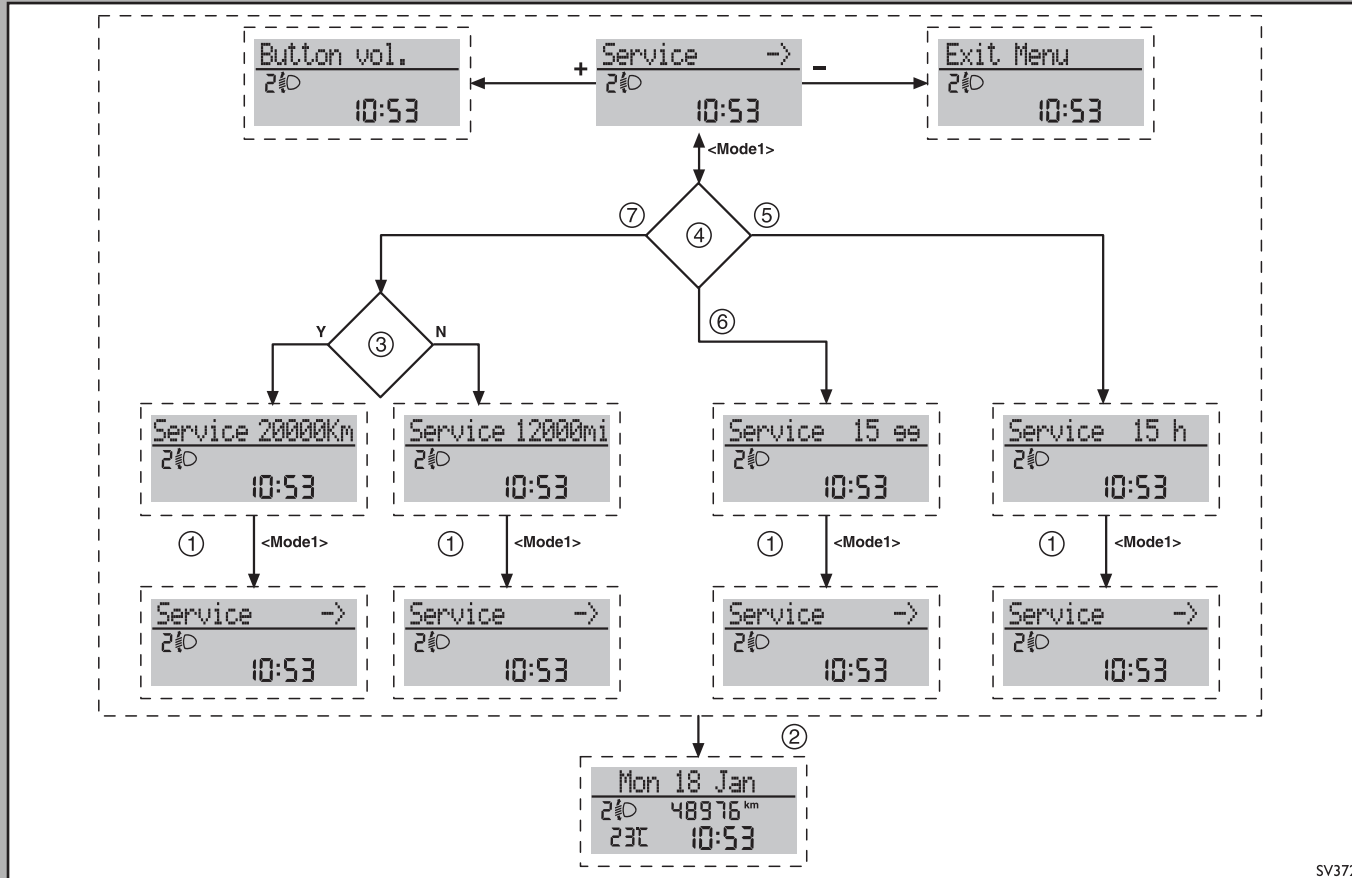

COMFORT version menu layout - General menu (12)

1. The + and - buttons have no effect.

The indication will blink.

2. Mode 2 or end of time period with no action.

3. Distance Unit km.

4. Unit of measurement.

5. Hours of operation.

6. Time.

7. Distance.

THE DRIVER'S POSITION

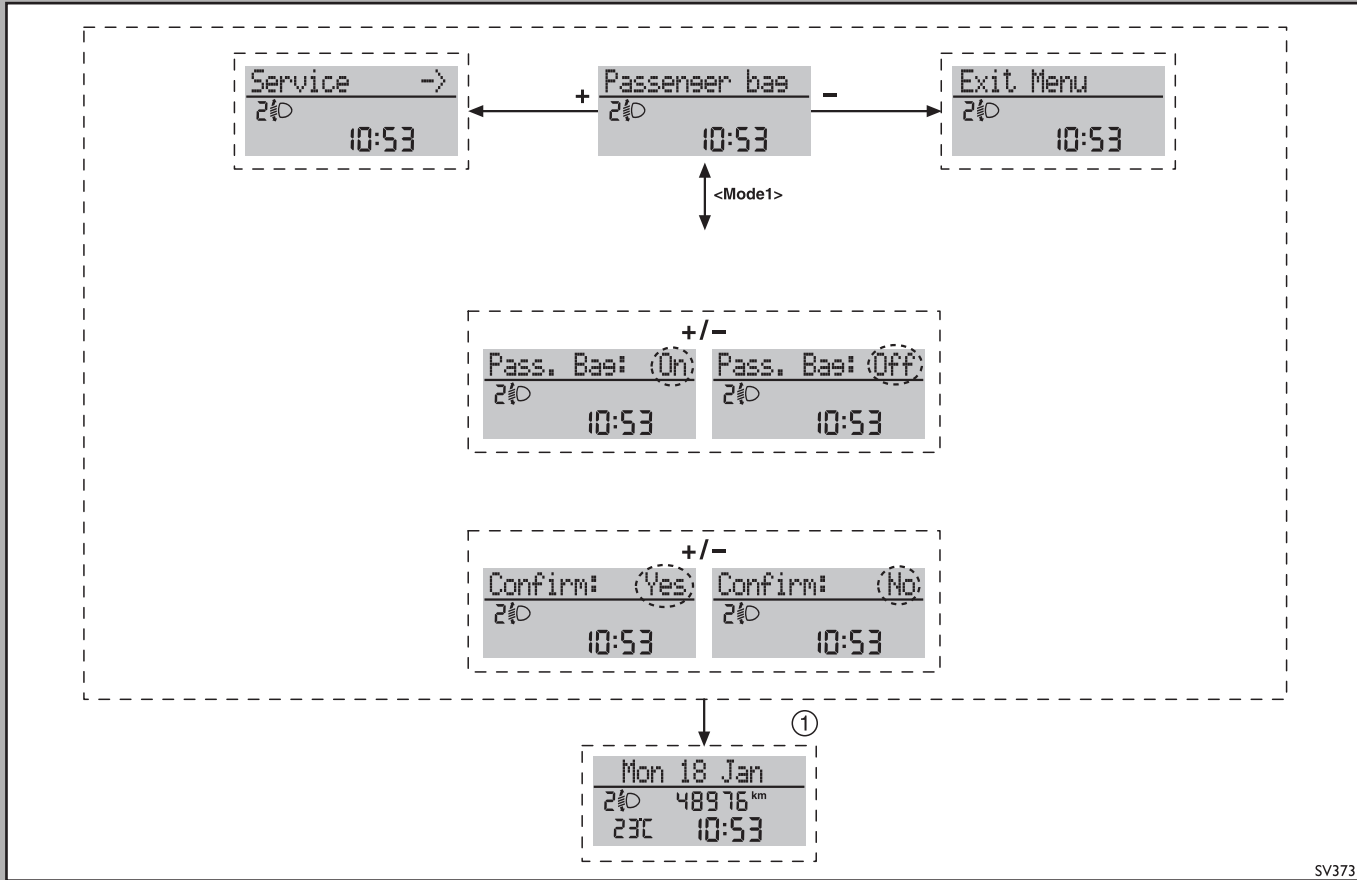

COMFORT version menu layout - General menu (13)

- The buttons + and - both switch from ON to OFF and vice versa. Mode 1 confirm the set value. ON/OFF will blink.
 - The buttons + and - both switch from Yes to No and vice versa. Mode 1 confirm the set value. ON/OFF will blink.
1. Mode 2 or vehicle moving or end of time period with no action.

THE DRIVER'S POSITION

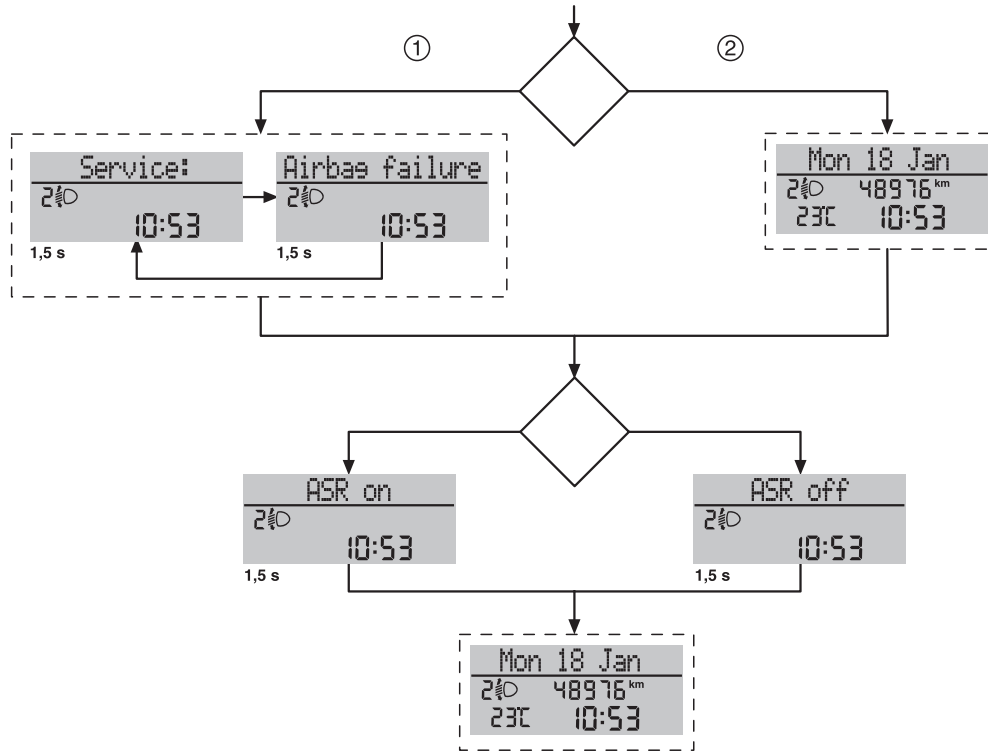

THE DRIVER'S POSITION

COMFORT - ASR version menu layout

(Screen visible only in presence of ASR)

1. Is there a warning?
2. No warning present?

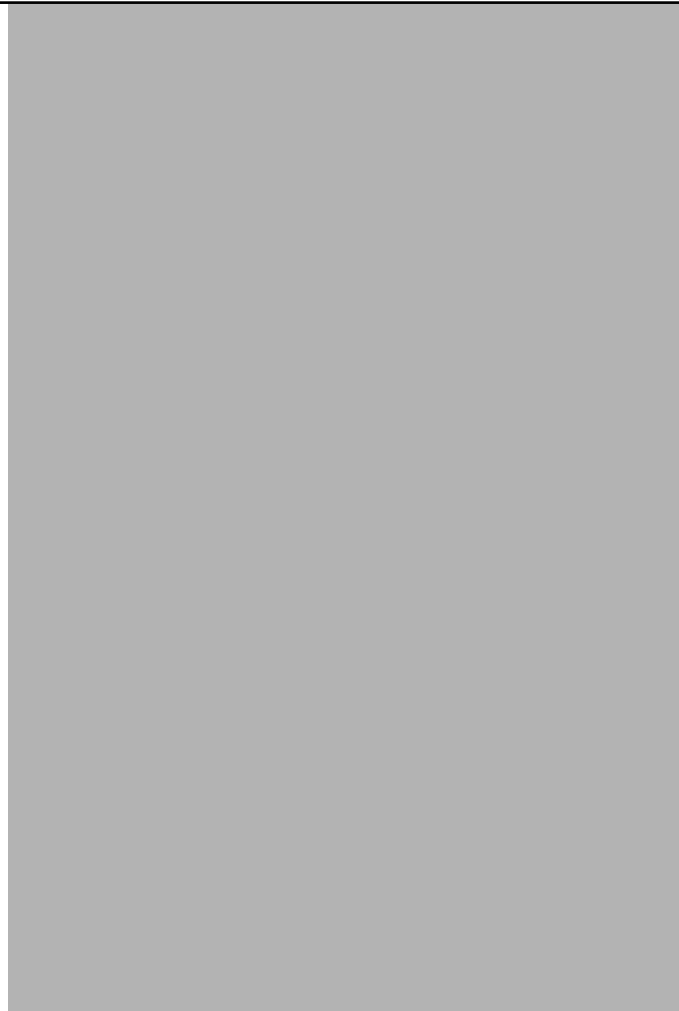

THE DRIVER'S POSITION

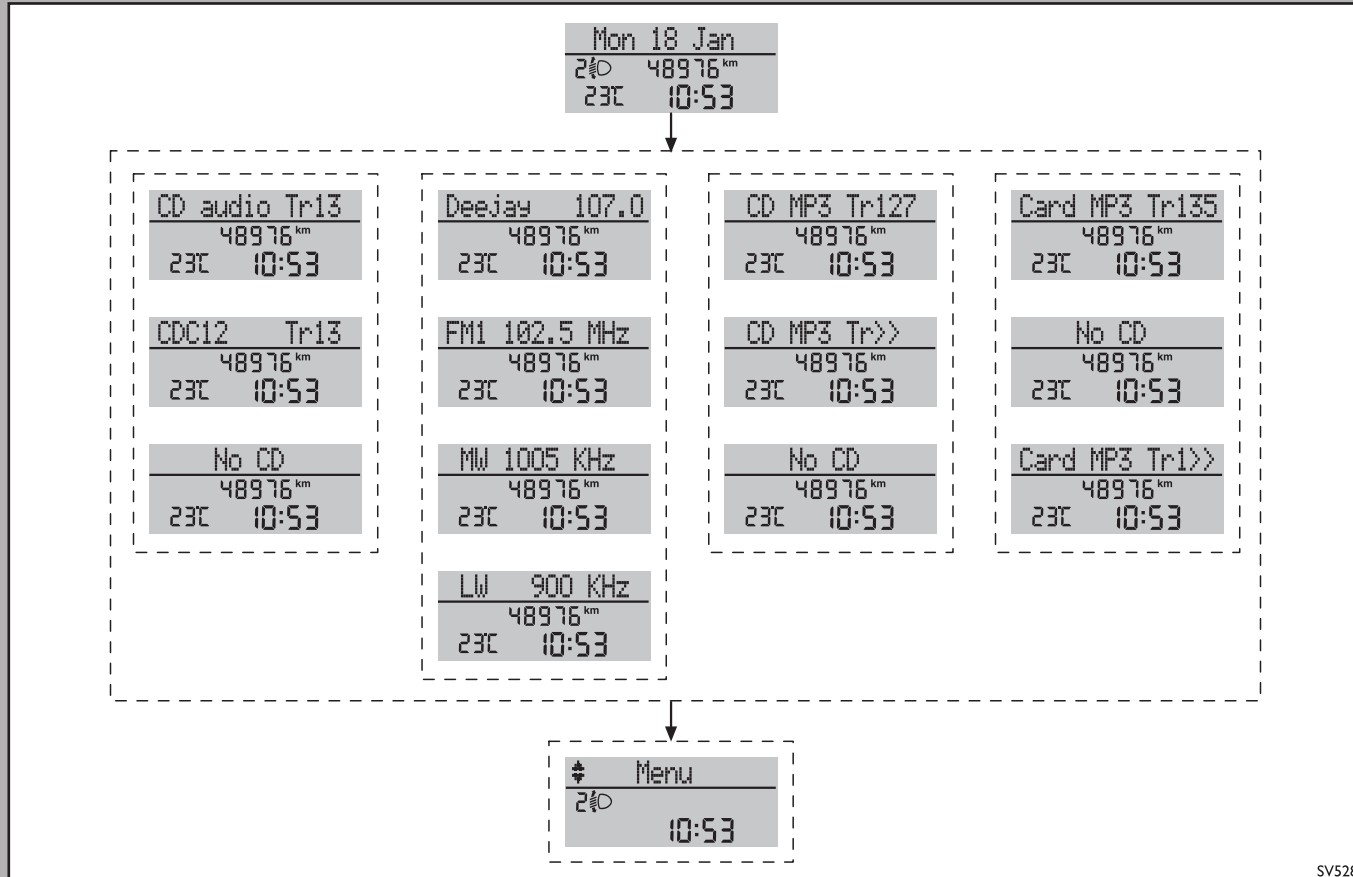

THE DRIVER'S POSITION**COMFORT version menu layout - Audio**

- During the key-ON phase, the audio display is only enabled after the first two seconds.
- The instrument lighting adjustment screen cannot be interrupted by audio messages.
- The Menu screens cannot be interrupted by audio messages.
- The Trip Computer screens cannot be interrupted by audio messages.
- The telephone/SMS screens cannot be interrupted by audio messages.

THE DRIVER'S POSITION

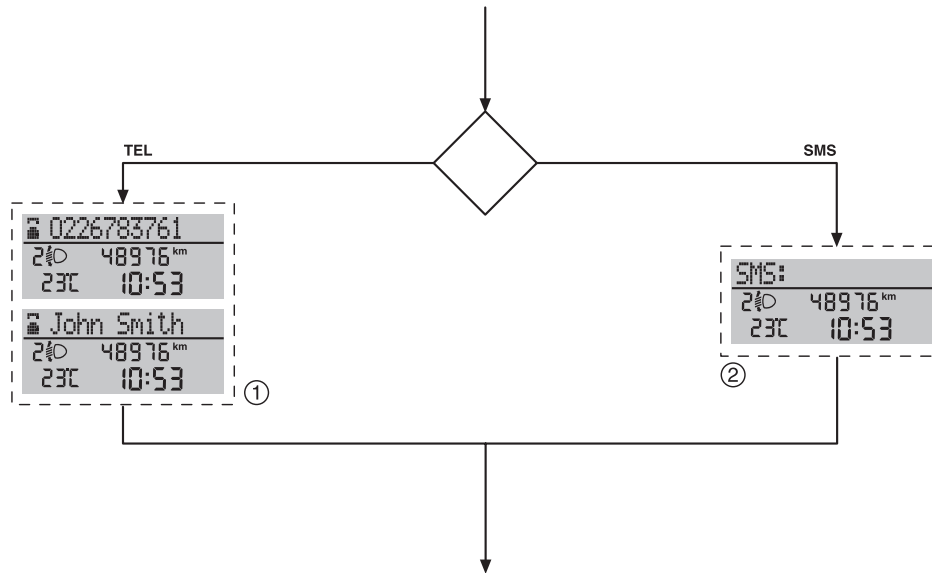

THE DRIVER'S POSITION**COMFORT version menu layout - Hands free (Bluetooth)**

1. It remains until the call is accepted or refused.
2. Five seconds or MODE button.

Not available in Australia

THE DRIVER'S POSITION

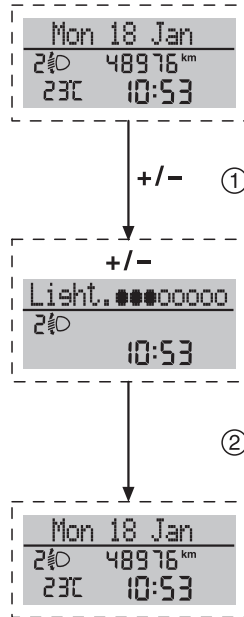

THE DRIVER'S POSITION

COMFORT version menu layout - Instrument lighting adjustment

1. The + and - buttons are used to adjust the level from minimum to maximum (not cyclically).
2. Five seconds or MODE button.



THE DRIVER'S POSITION

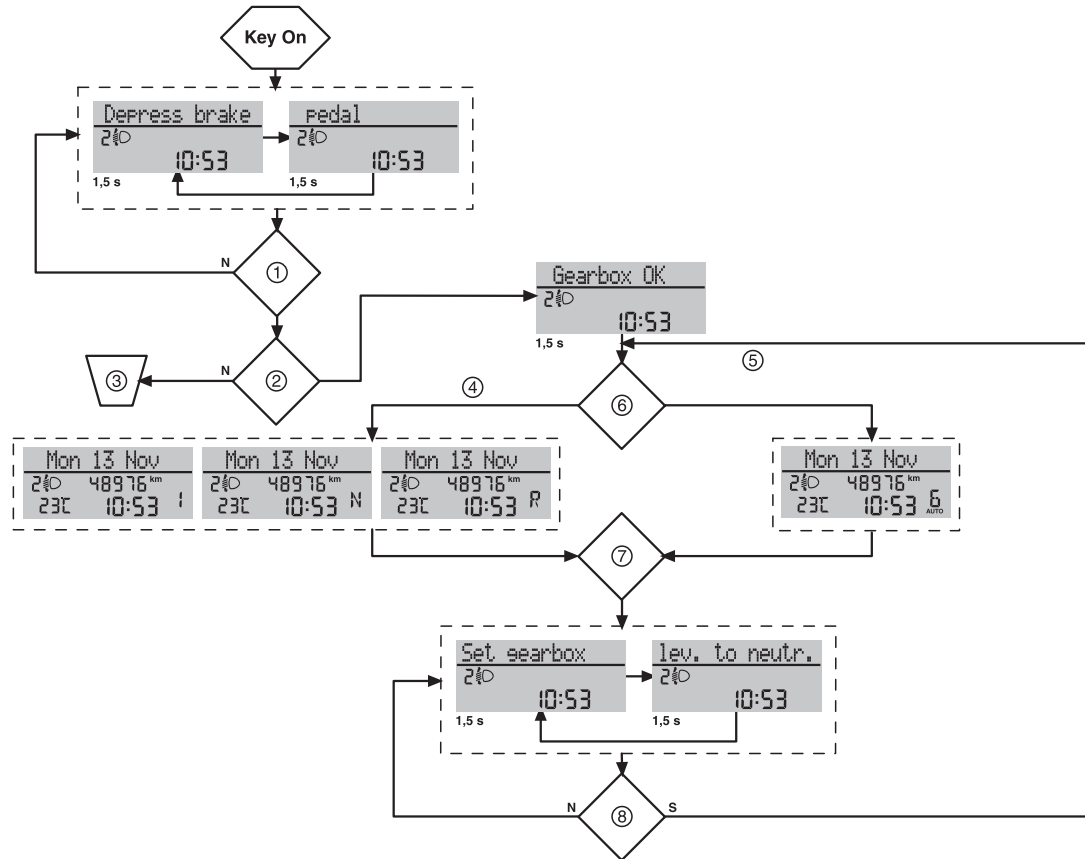

COMFORT version menu layout - Automatic transmission

(Screen visible only in presence of automatic transmission)

1. Pedal pressed?
2. Gearbox OK
3. Display of warnings
4. Manual
5. Automated
6. Manual or automated?
7. Required by neutral gear change?
8. Neutral engaged?

Daily 4x4 not available with auto transmission

THE DRIVER'S POSITION

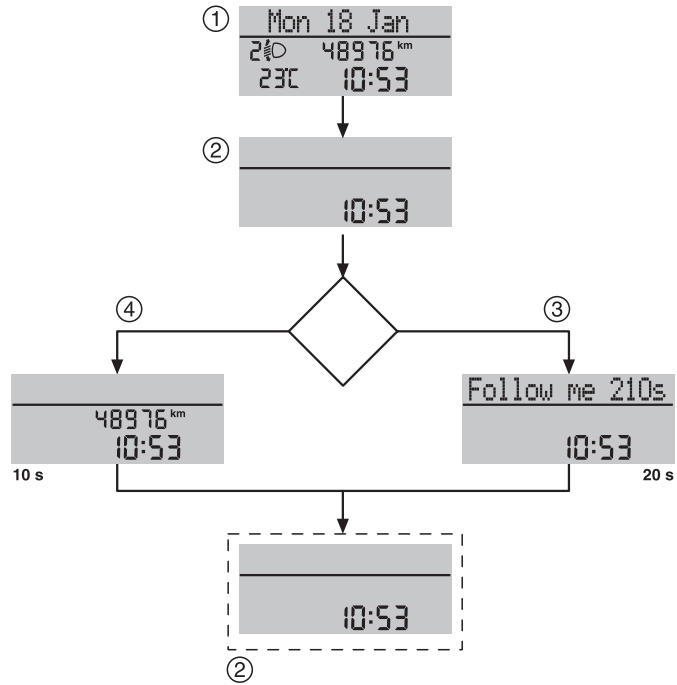

THE DRIVER'S POSITION

COMFORT version menu layout - vehicle stop (key OFF)

1. Backlighting ON.
2. Backlighting OFF.
3. High beam flashing control.
4. Doors opening.

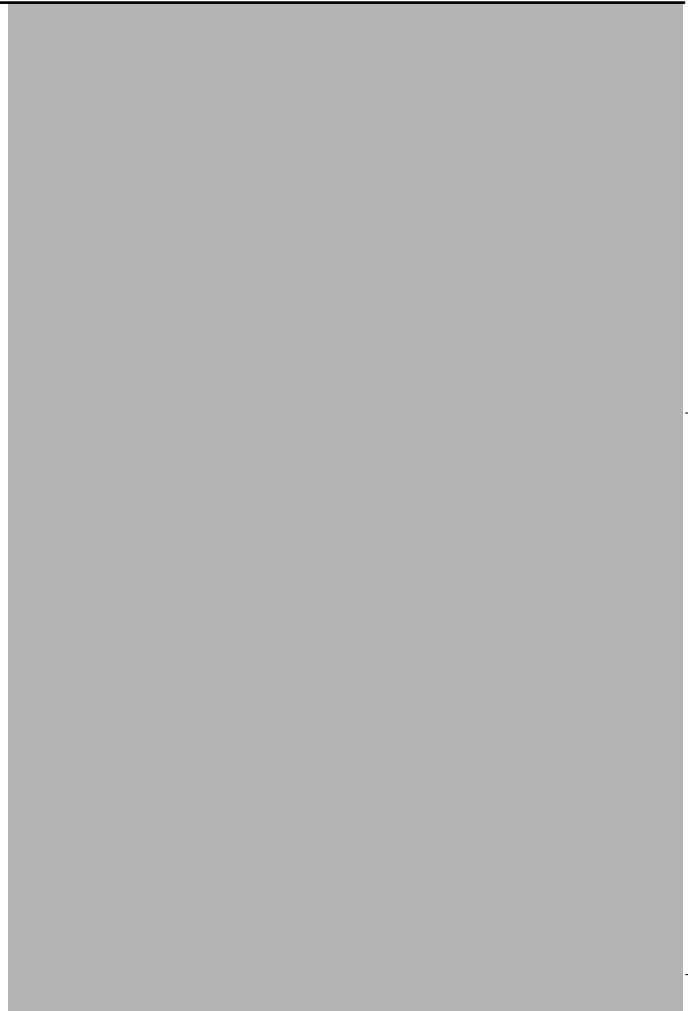

DPF (Diesel Particulate Filter)

The DPF (Diesel Particulate Filter) is a device for particulate filtering without requiring maintenance by the user. This is **done automatically by the vehicle through combustion of the particulate accumulated inside the DPF** (spontaneous regeneration).

However, there are **some uses of the vehicle (e.g. urban with frequent stops)** where the conditions for spontaneous regeneration are not possible and therefore the vehicle tries to force filter cleaning by increasing the exhaust gas temperature in a controlled way (controlled regeneration).

At the start of the controlled regeneration stage the following messages are displayed on the instrument panel:

Basic Instrument Cluster



“Rig” = Regeneration

Comfort instrument panel

(in Trip mode)



Start of pollution filter regeneration

On vehicles equipped with Comfort instrument panel, if the controlled regeneration process has not been completed, a few minutes after the message “Start of pollution filter regeneration” is displayed another message will appear on the instrument panel: “Regeneration not completed” and lighting up of the indicator.

This message indicates that the temperatures at the exhaust are too low to completely regenerate the DPF. It is advisable (compatibly with traffic conditions and the speed limits) to increase the engine speeds and keep them constant and high until the message disappears. It is very important to **not interrupt** the controlled regeneration (e.g. switching off the engine or parking the vehicle), but **possibly** keep the engine at a constant and high speed (regardless of the gear engaged), continuing to travel normally.

In fact, after three consecutive interruptions of controlled regeneration, **without even one successfully completed**, engine performance deteriorates, indicated by lighting up of the EOBD (European On Board Diagnostic)  and **clearly noticeable by the different behaviour of the vehicle** (decrease in torque/power delivered).

In this case **immediately** go to an IVECO Assistance Network garage, which will perform a “regeneration Service”, which also includes an engine oil change.

Prolonged use of the vehicle with the EOBD indicator on could make complete replacement of the DPF necessary.

In case of an interruption of controlled regeneration, it is advisable to use the vehicle on routes where the engine can be easily kept at a high and constant speed (e.g. motorways and bypasses) so that the controlled regeneration can be completed.

THE DRIVER'S POSITION

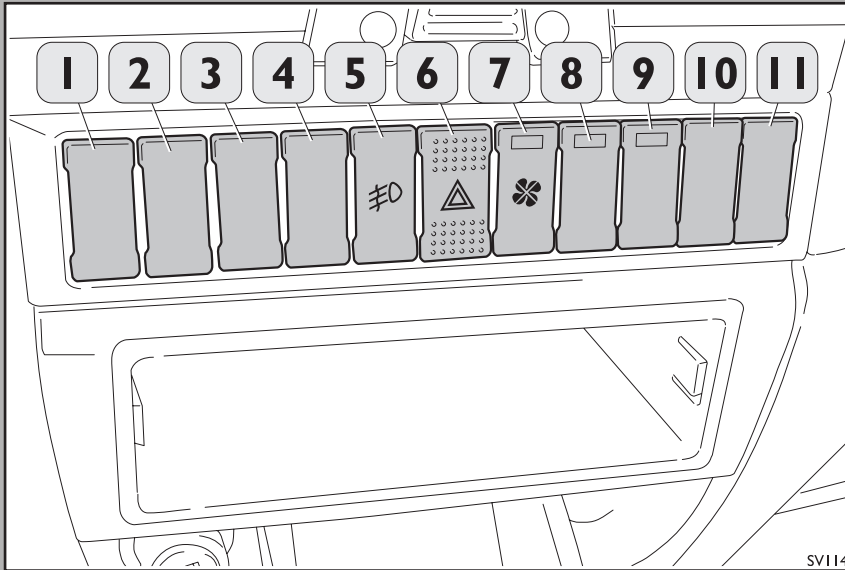
**Middle dashboard (lower part)**

1. Spare.
2. Spare.
3. Spare.
4. Spare.
5. FOG LAMPS.
6. HAZARD LIGHTS.
- *7. Engine radiator fan activation/deactivation.
- *8. Spare.
- *9. Spare.
10. Spare.
11. Spare.

* With built-in indicator light.

Note: The button position alters according to the version/market.

THE DRIVER'S POSITION

Middle dashboard (upper part)

1. Middle differential lock engaged indicator.
2. Middle differential lock engaged.
3. Rear differential lock engaged indicator.
4. Rear differential lock.
5. Front differential lock engaged indicator
6. Longitudinal differential lock.
7. ABS warning lamp.
8. Differential lock failure warning light
9. ABS off indicator.

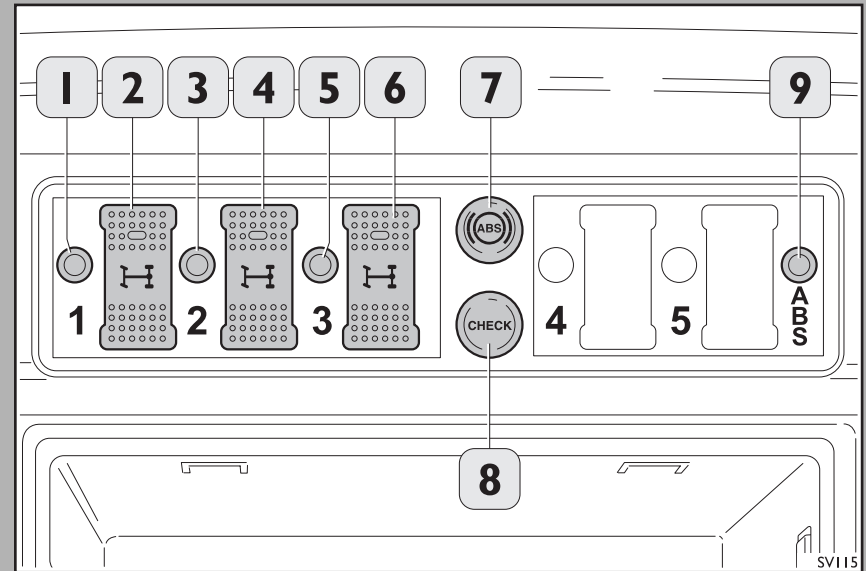

116

THE DRIVER'S POSITION

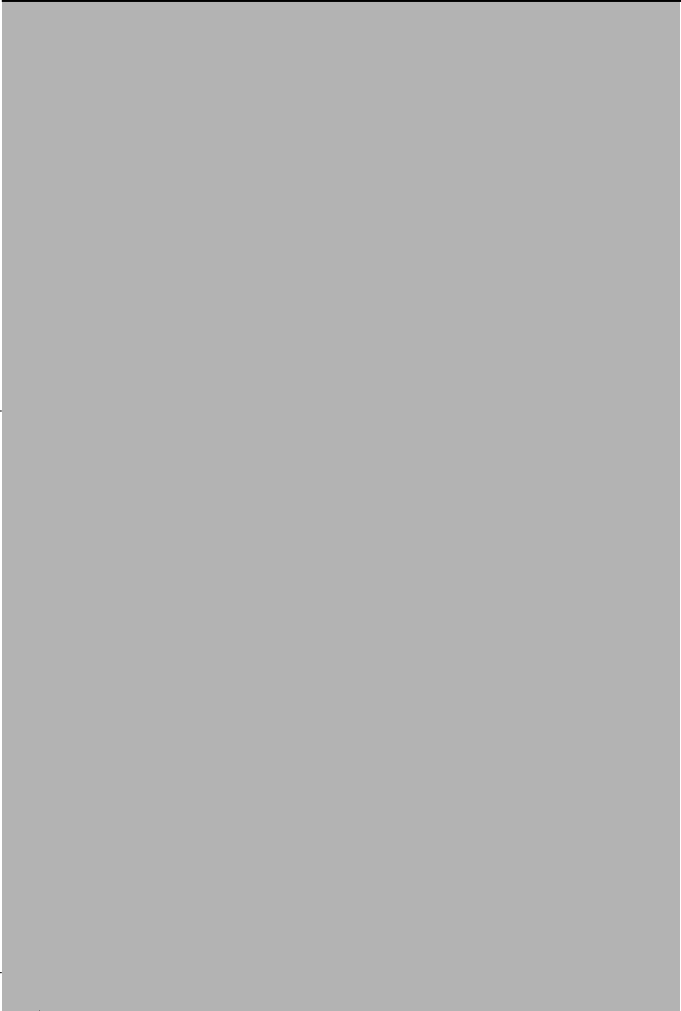

Controls and devices

This section provides instructions for using:

Seats	118
Seat belts	121
Air bag	124
Rear vision mirrors	128
Power windows	130
Multi-function steering wheel levers	132
Windscreen and headlamp washer fluid reservoir	137
Interior equipment	138
Headlight levelling	140
Tow hook	140
Heating and ventilation	141
Independent supplementary heater	145
Accessories fitted by the user	150

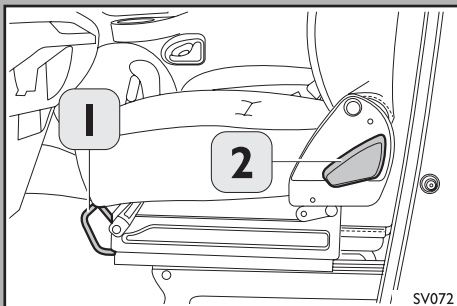

Seat with two degrees of freedom

Seat lengthwise position adjustment

Pulling the lever (1) up allows the seat to move forward or back; on releasing the lever the seat is locked in the required position.

Seat back reclining adjustment

By turning the lever (2) forward, the inclination of the seat decreases with respect to the cushion.



CAUTION!

Risk of accidents: Adjust the seats only when the vehicle is stationary. After releasing the lever (1) always make sure the seat is locked on the guides by trying to move it forward and back. If not locked, the seat could move suddenly, causing loss of control of the vehicle.



> **CAUTION!**

Risk of accidents: Adjust the seat only when the vehicle is stationary. After releasing the lever (1), always make sure the seat is locked on the guides by trying to move it forward and back. If not locked, the seat could move suddenly, causing loss of control of the vehicle. (text inside box, general danger symbol)

Seat with three degrees of freedom

Seat lengthwise position adjustment

Pulling the lever (1) up allows the seat to move forward or back; on releasing the lever, the seat is locked in the required position.

Seat back reclining adjustment

By turning the lever (2) forward, the inclination of the seat decreases with respect to the cushion.

Adjustment of upright position and the cushion position

Use the handles (3) and (4) to raise the seat (without driver's weight) or to lower it (with all or part of the driver's weight on it); release handle to lock the seat at the required height; to change the cushion inclination use one handle only.

CONTROLS AND DEVICES

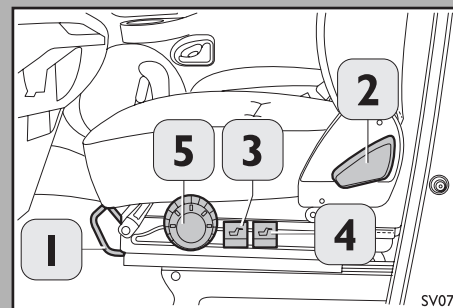

CONTROLS AND DEVICES

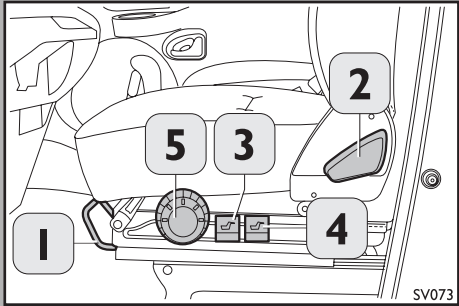
**Springing adjustment** (if provided)

Before climbing into the vehicle the driver must preset the seat springing by turning the handwheel (5) clockwise or anticlockwise, matching the reference pointer with the numerical indication of his own body weight; then, when driving, optimum setting of springing must be obtained as required with further small adjustments using the handwheel.

Seat belts

To fasten the seat belt, grip the hooking tongue and insert it into the buckle until it clicks. To release belt, press special button at the top end of the buckle. Accompany the belt during rewinding, to prevent it from twisting. The belt does not need to be manually adjusted: The belt automatically adjusts to the right length for the driver, allowing full freedom of movement, provided that none of these are sudden. The mechanism is sensitive to changes in the vehicle position, therefore the belt may lock in the following cases: braking or a sudden acceleration, vehicle on a slope or in a bend.

Important:

- Bring the back to an almost upright position; seat positions that compromise the correct movement of the belt represent a risk for persons and should therefore be avoided.
- Adjust the height only when the vehicle is stationary, by means of the slider (1). The belt must pass between the neck and the upper arm.

NOTE: The seats of your vehicle are not suitable for children: the belt is designed for use by persons of adult height.

- The belt must not be twisted and must fit comfortably on the lap but not over the abdomen, to avoid the risk of slipping forward.
- From time to time, check that the anchoring screws are tight and that the belt is not cut or frayed.
- In the event of a significant accident, replace the belt, even if it does not appear to be damaged: also replace it when it has cuts or signs of wear (have the belts fitted by the *Service Network*).

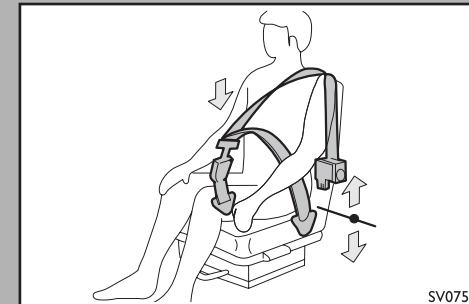
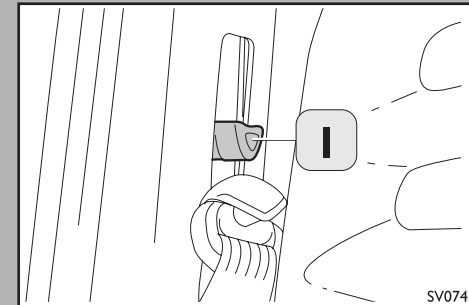

CONTROLS AND DEVICES

- Do not make any modifications that could reduce seat belt functionality.
- To clean the seat belts, hand wash with water and neutral soap, rinse and leave to dry in the shade. Do not use strong detergents, bleaches, dyes, or any other chemical substance that could weaken the fibres. Avoid wetting the reels: their correct operation is guaranteed only if water does not enter them.



CAUTION!

<

Always fasten the belts:
Travelling without the seat belts fastened increases the risk of injury in case of a collision.
Do not press the release button when driving.

Pretensioners **Not present in Daily 4x4**

In order to ensure airbag efficiency, the seat belts of this vehicle are fitted with pyrotechnic pretensioners.

These devices are controlled by the air bag module, which sends a signal that activates the pyrotechnic charge and retracts the belt by a few centimetres when it detects a certain vehicle deceleration.

In this way they ensure that the belts fit snugly to the occupants' bodies before the restraining action starts.

Locking of the belt indicates activation of the device; there may be slight emission of smoke. This smoke is not noxious and does not indicate the start of a fire. If events of an exceptional nature (such as floods) have caused the device to be affected by water or mud, it must always be replaced without exception.

The pretensioners are controlled by the airbag warning light. If this light comes on, consult the *Service Network* immediately.

Warnings:

- the pretensioners may be used once only, and they all activate even if the seat belts are not fastened. So, once they have activated, have them replaced by the *Service Network*.
- Repairs involving knocks, vibrations or heating in the vicinity of the pretensioner may damage it.
- The pretensioner devices do not require internal greasing or maintenance. Never under any circumstances tamper with the pretensioner devices. Tampering could adversely affect their operation. If necessary, consult the *Service Network*.



Air bags + seat belts (when fitted) Airbags are not present in Daily 4x4

The vehicle may be fitted with airbags both for the driver and the passenger. The main aim of the air bag is to maximise seat belt effectiveness: it does not activate in the event of head-on collision at low speed, rear-end collision or overturning.

Description and operation

The air bag is a safety device that activates instantaneously in the event of a front-end collision. It consists of an instant-inflation cushion contained in a special recess in the centre of the steering wheel on the driver's side, and in the dashboard on the passenger side.

In the event of violent impact, the deceleration device activates the instant-inflation device for the cushion or cushions, which are interposed as a protective barrier between the occupants' bodies and the vehicle's forward structures that could cause injury. When the air bag is operated, heat is produced and a small volume of powder released.

This powder is not noxious and does not indicate the start of a fire; the surface of the released cushion and the vehicle interior may also be covered with a powdery residue: this powder may irritate the skin and eyes.

In the event of exposure, wash with neutral soap and water. Remember that, with the key inserted and turned, the air bag may be activated even when the vehicle is stationary, if it is hit at the front by a vehicle travelling fast enough.



> **Important**

The air bag does not substitute, but merely complements the use of the seat belts. Air bag inflation without the restraining action exerted by the seat belts may cause injury, even of a serious nature.

In collisions against very deformable or movable objects (such as road sign poles, piles of ice or snow, parked vehicles, etc.), rear-end collisions (i.e. being hit from behind by another vehicle), or when the vehicle is wedged under other vehicles or protective barriers the air bags may not be activated, because in these situations they offer no additional protection to the seat belts therefore their activation would be pointless.

Their failure to activate in these circumstances is not an indicator of system malfunction.

The front air bags could be activated if the vehicle suffers a major impact or is involved in an accident affecting the under-body area, such as violent impact against steps, pavements or ridges in the ground, or the vehicle falling into large holes or road subsidence.

When the starter key is turned, warning light 7 on page 38-10 comes on, but it should go out after about four seconds.

If the warning light does not come on or stays on whilst driving, consult the *Service Network* immediately.

CONTROLS AND DEVICES

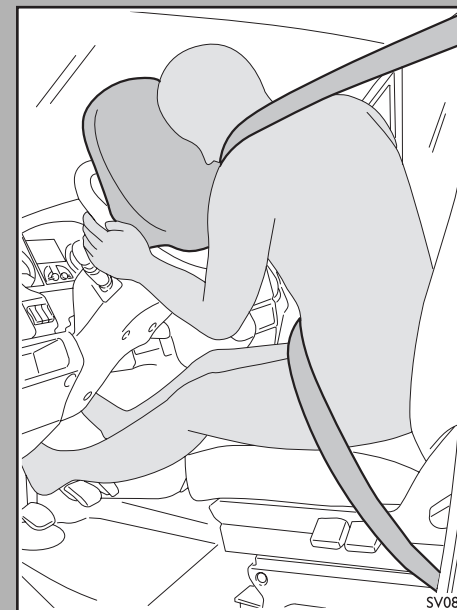

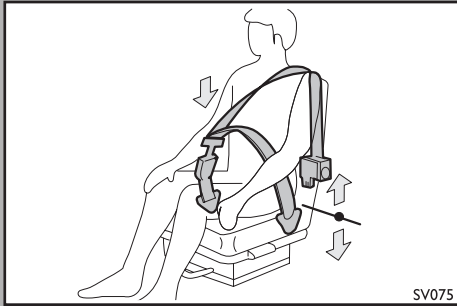

- Do not travel with items on your lap, in front of your chest or hold a pipe, pencil, etc. between your lips. In an accident triggering the airbag they could cause injury.
- The air bag system does not require any maintenance; however, the efficiency of the device should be checked periodically, in accordance with the requirements of current legislation. These checks should be carried out by the *Service Network* . All air bag diagnosis, repair and replacement work should be carried out only by the *Service Network* . The durability of the airbag is limited and is normally equivalent to 10 years. For reasons of safety it is recommended to have the airbag changed after 10 years at the latest by the *Service Network* .
- If the warning light comes on whilst driving (indicating an anomaly), have it repaired without delay by the *Service Network* .
- Remember that when the vehicle is stationary and is hit by another moving vehicle, the air bags may activate, even when the engine is off, if the starter key is inserted and turned. Therefore, even with the vehicle stationary, children must never be allowed on the front seat. On the other hand, remember that when the vehicle is stationary without the key inserted and turned, the air bags will not be activated in case of a collision; therefore, in these cases, non-activation of the air bags cannot be considered as an indicator of system malfunction.
- Do not apply adhesives or other items over the steering wheel or the passenger air bag recess.
- Always drive with your hands over the crown of the steering wheel, so that if the air bag activates it can inflate without encountering obstacles that could cause serious damage. Do not drive with the body bent forwards, but keep the seat back in an erect position so that the spine is well supported.

- Activation of the air bag occurs at the same time as the pretensioners.
- If the vehicle has been involved in a theft or attempted theft, or has suffered acts of vandalism or floods, have the system checked by the *Service Network* .
- If the vehicle has been involved in an accident resulting in air bag activation, it is necessary to have the air bags, seat belts and pretensioner replaced by the *Service Network* .
- If the vehicle is scrapped, the *Service Network* must be consulted to deactivate the system.
- If the vehicle changes ownership, it is essential that the new owner be informed of the methods of use and the warnings indicated above, and be given this booklet.

Air bag passenger side

Babies or children secured with means deemed to comply with EEC standards (children's seats or cots) cannot be carried in the passenger seat with the air bag active because, on inflating, it could cause even mortal injury regardless of the seriousness of the accident causing its activation.

It can be deactivated with the display menu of page 18-46.

Make sure to immediately reactivate the airbag as soon as carrying children is no longer necessary.

Window bag

If there is a window bag, do not hang clothes or any other items on the handles.

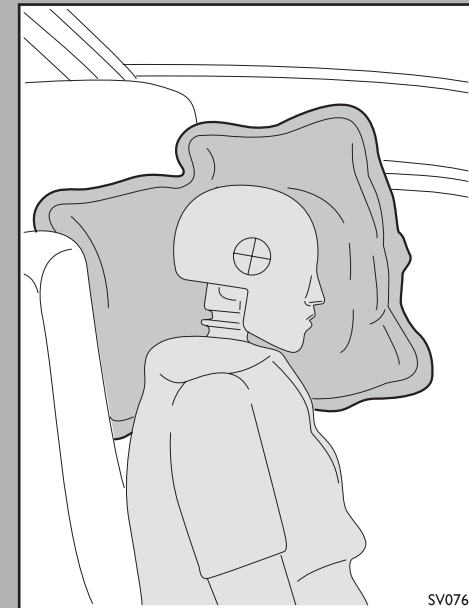

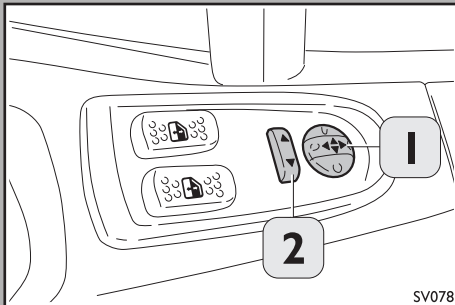
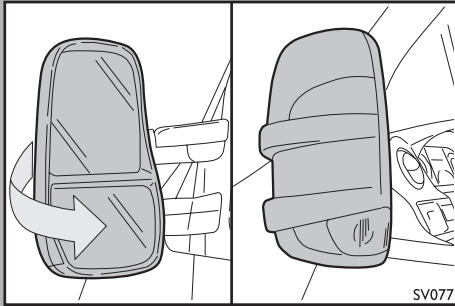

Rear vision mirrors

They are adjusted by operating on the sides of the reflecting surface: they can also be folded by hand.

Electric rear vision mirror control (if provided)

Located on the driver's side.

1. Control knob for horizontal or vertical mirror adjustment in the directions indicated by arrows stamped on it.
2. Switch to select the mirror to adjust: right or left.

Electric mirrors standard on Daily 4x4

Long arm - std

Short arm - optional



CAUTION!

The distance shown by the mirrors is approximate. Carefully judge the distance before every manoeuvre and/or lane change.

CONTROLS AND DEVICES**Inside mirror** (if fitted)

By operating the lever (1) it can be adjusted in two positions:

- normal;
- anti-glare.

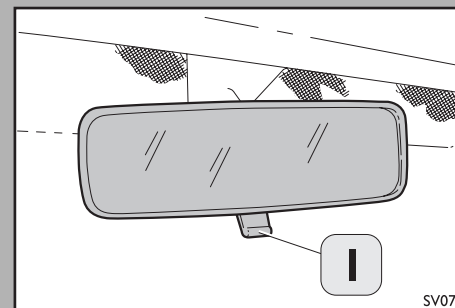

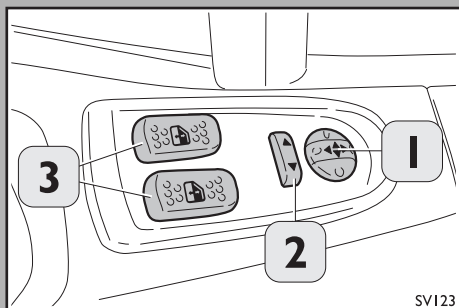
CONTROLS AND DEVICES**Electric windows control** (if fitted)

Located on the driver's side (two) and on the passenger's side (one): they have a safety system able to identify an obstacle during automatic window closing; if an obstacle is detected, the system stops and immediately reverses the movement of the window.

Pressing one of the two buttons 3, provides a "jerking" motion of the window when closing or "continuous automatic" operation is activated, when coming down. The window stops in the required position when the relevant button is pressed again. Automatic operation when moving up is restored after approximately 15 seconds of taking no more action on the control.

"Autoclose/open" function

This function allows fully opening or closing the windows by holding down the relevant remote control button (for at least two seconds).



> **CAUTION!**

Risk of injury: Incorrect operation of electric windows may be dangerous. Before and during operation, check that people, animals and objects are not exposed to the risk of injuries caused by windows movement, or by personal items being trapped in or hit by windows. When getting out of the vehicle always remove the ignition key to prevent the power windows, operated inadvertently, from being a danger for anyone in the vehicle.

Important:

If the battery is disconnected it is necessary to re-initialize the anti-pinching system by carrying out the following procedure:

- Press and hold down the control, causing "continuous automatic" operation, until the window is completely open, holding the button down for 4-5 seconds.
- Cause the window to move in "jerks" with brief presses until it is completely closed.

When closed, keep the control operated for at least another second.

When the procedure is correctly concluded, both automatic operation for closing the windows and the "Autoclose/Open" function will be active again.

CONTROLS AND DEVICES

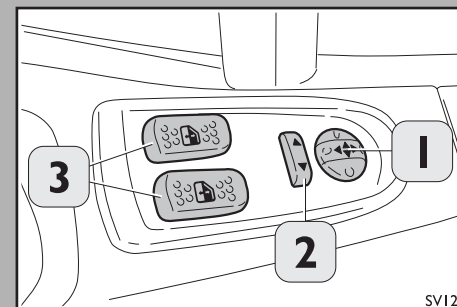

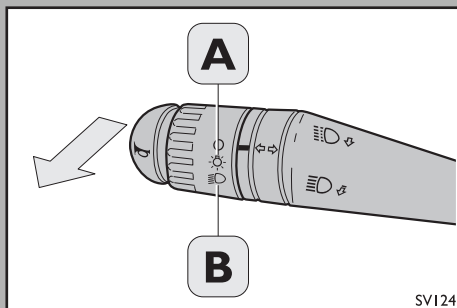

SV124

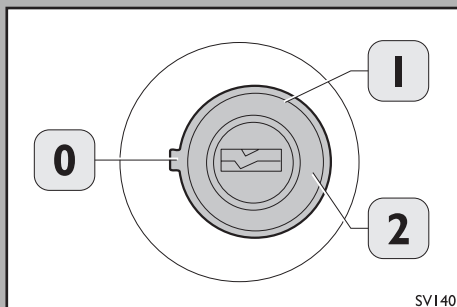

SV140

Multi-function steering wheel levers

Left lever

The left lever gathers the controls of the exterior lights, direction indicators and horn.

The exterior lighting only works with the ignition key in position 'I'.

When the exterior lights are switched on, the instrument panel and the various controls on the dashboard light up.

Lights OFF

Ring turned to 0.

Exterior, side lights

Turn the ring to position (A).

Low beam

Turn the ring to position (B).

High beam

With the ring in position (B) pull the lever towards the steering wheel (2nd unstable position).

To switch off high beam, pull the lever towards the steering wheel (low beam switches on again).

Headlight flashing

Pull the lever towards the steering wheel (1st unstable position) regardless of the position of the ring.

CONTROLS AND DEVICES**Direction indicators**

Bring the lever to the stable position:

- up (position 1): activation of right direction indicator, the indicator light (22) of page 10 comes on blinking;
- down (position 2): activation of right direction indicator, the indicator light (9) of page 10 comes on blinking;

The direction indicators switch off automatically when the vehicle returns to travelling in a straight line.

Horn

Press the button on the end of the lever.

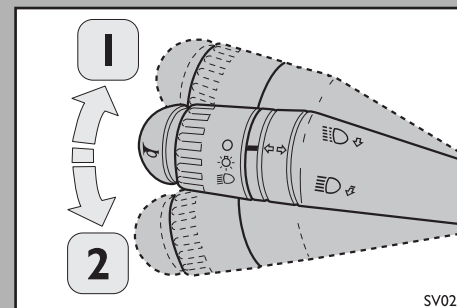

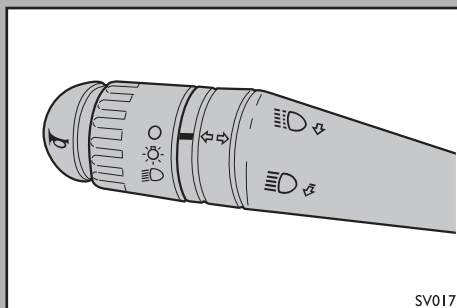

Follow me home” function

This function allows operation of the dipped beam headlights for a set length of time after turning the ignition key OFF or removing it. The command is inhibited if the high beam headlights are switched on with the drive control system.

The function is on if it is switched on within the maximum time of two minutes from turning the key OFF or taking it out. With each single operation of the lever the lights will stay on for an extra 30 seconds up to a maximum of 210 seconds.

To switch off the function, keep the lever pulled towards the steering wheel for longer than two seconds.

Parking lights function

The function is switched on by leaving the parking lights switched on with the drive control system. The buzzer will sound until the doors are closed to warn the driver that the parking lights function is on.

On opening a door the buzzer sounds to remind the driver of the function activated.

CONTROLS AND DEVICES

Right lever

The right lever gathers the controls for the rear fog lights, window cleaning, headlight washer (if provided), and 'TRIP' for browsing the pages of the display (axial pressure).

Rear fog lamps

Turn the ring (A) with low beam on.

windscreen washer

Activated only with the ignition key turned to position (I). To activate the windscreen washer, shift the lever down according to the arrow stamped on it.

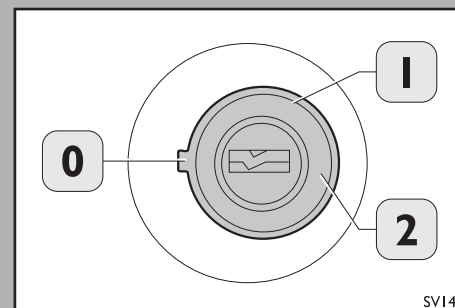

SV140

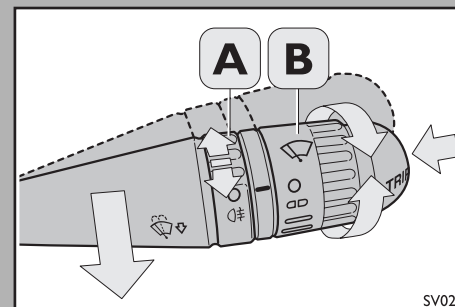

SV021

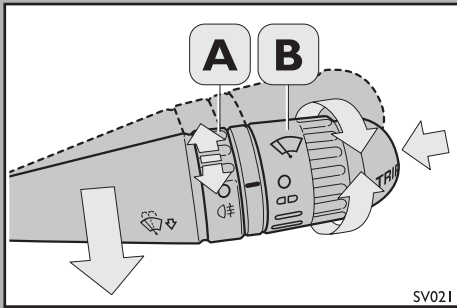

SV021

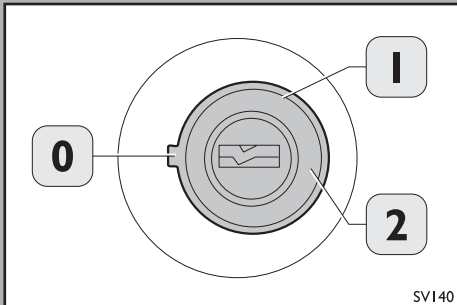

SV140

Windscreen wipers

Activated only with the ignition key turned to position (I).

The right lever has 4 different positions:

- windscreen wiper stopped.
- ▣ intermittent operation.
- slow continuous operation.
- fast continuous operation.

By shifting the lever up (unstable position), operation is limited to the time the lever is manually kept in that position. On releasing it, the lever returns to its position, automatically stopping the windscreen wiper.



CAUTION!

Do not use the windscreen wipers to remove any ice or snow that has accumulated. In these conditions the windscreen wiper undergoes excessive force.

Windscreen and headlamp washer fluid reservoir

The reservoir is located in the engine compartment. It is recommended that you use a special anti-freeze detergent **Tutela Professional SC 35** mixed with water in the following proportions:

OUTSIDE TEMPERATURE	-35°C	-20°C	-10°C	0°C	SUMMER
Tutela Professional SC 35 (in parts)	1	1	1	1	1
Water (in parts)	-	1	2	6	10

Headlamp washers not present on
Daily 4x4 in Australia

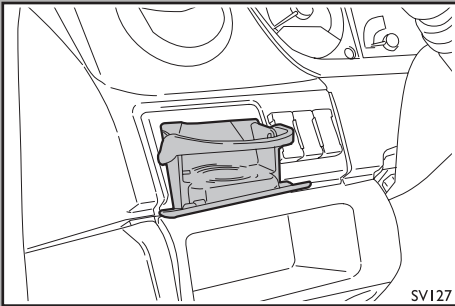
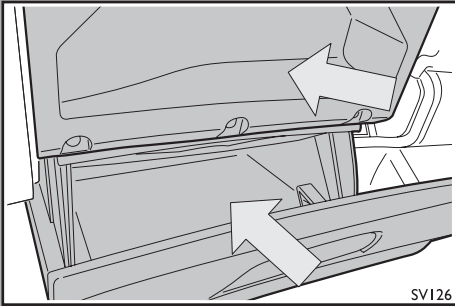

Interior equipment

At the top of the dashboard on the passenger side there is an open compartment to hold papers, documents, etc. (except on vehicles with a passenger side airbag).

Underneath there is a twin glove compartment (the top one is refrigerated on vehicles equipped with air conditioning).

At the sides of the dashboard there are two removable cup holders.

Note:

If there is a shelf above the windscreen, place items on it correctly so they do not come off when driving.

CONTROLS AND DEVICES

The sunblinds can be flipped and adjusted sideways, including pockets for documents and a courtesy mirror on the passenger side.

At the back of the cab there is a clothes hook (cab versions only).

At the front in the middle there is a courtesy light and an adjustable spotlight.

Courtesy mirror unavailable in Australia

Twin seat equipment (if provided for the version / Market)

Underneath the twin seats there may be two drawers 1 and 2 (maximum load of 1.5 kg each) that can be opened by pulling the handles forwards. In addition there is a small work table 3 (for a PC for instance). The table can be used by initially pulling on the knob and then pushing the table top. With the vehicle running, the table must remain in its rest position. .

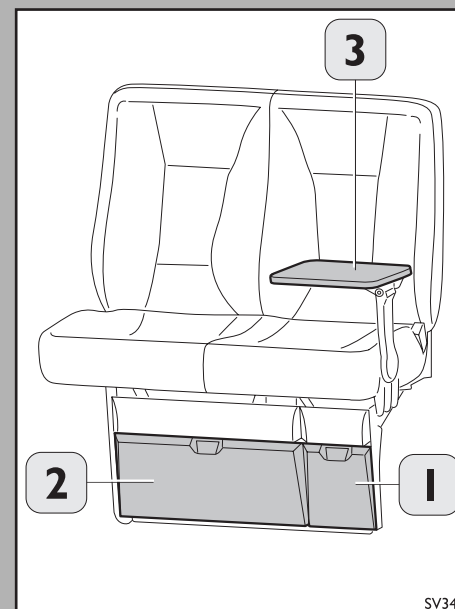

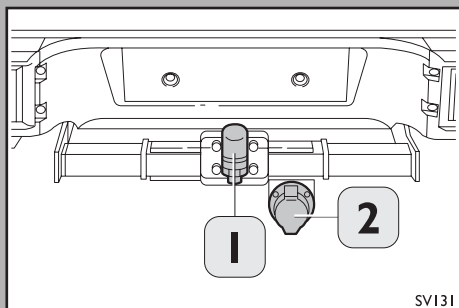
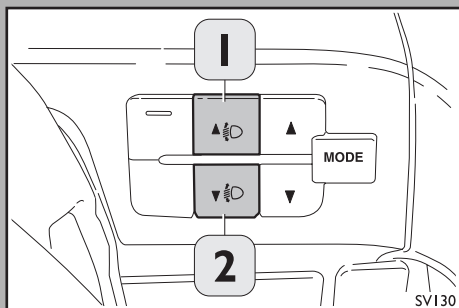

Headlight levelling (if provided)

Correct headlight levelling is all-important for the safety not only of the driver but for everyone; it is also a precise rule of the Highway Code. The headlights must be correctly levelled to ensure optimum visibility conditions for the driver and others when driving with the headlights on. When the vehicle is loaded, it inclines backward and the beam rises: it is then necessary to realign it correctly, using button 1 to raise the beam and button 2 to lower it. The more the vehicle is loaded and the higher the value must be on the display. Check beam alignment whenever there is a change in the weight of the load carried.

For possible manual adjustment and control, contact the Service Network. The headlight alignment device can have four positions: rest position 0 and 3 correction positions.

Enquire with your local dealer regarding towing devices

Tow hook (if provided)

For trailers with inertia braking.

1. Ball tow hook.
2. Coupling with 13 poles (12V) for lighting system.

If the tow hook is fitted externally, as well as installing the structure and hook correctly (both type-approved), the IVECO requirements relating to the electrical system (paragraph 2.19.14 Directives for Outfitters) must be respected. Do not overload the vehicle light supplies with trailer lights. Otherwise the control unit can inhibit operation of the lights (signalled on the instrument panel).

Follow the additional instructions, if any, of the hook manufacturer.

Heating and ventilation

Standard system

1. Air temperature control (warm/cold air mix).
2. Knob for activating the fan at the relevant operating speed.
3. Slider to turn on the recirculation function: to prevent outside air from entering.
4. Air distribution control as follows:
 - face vents.
 - face and feet vents.
 - Air supply foot area.
 - windscreen area and feet area air.
 - screen vents.

Standard system not available in Australia

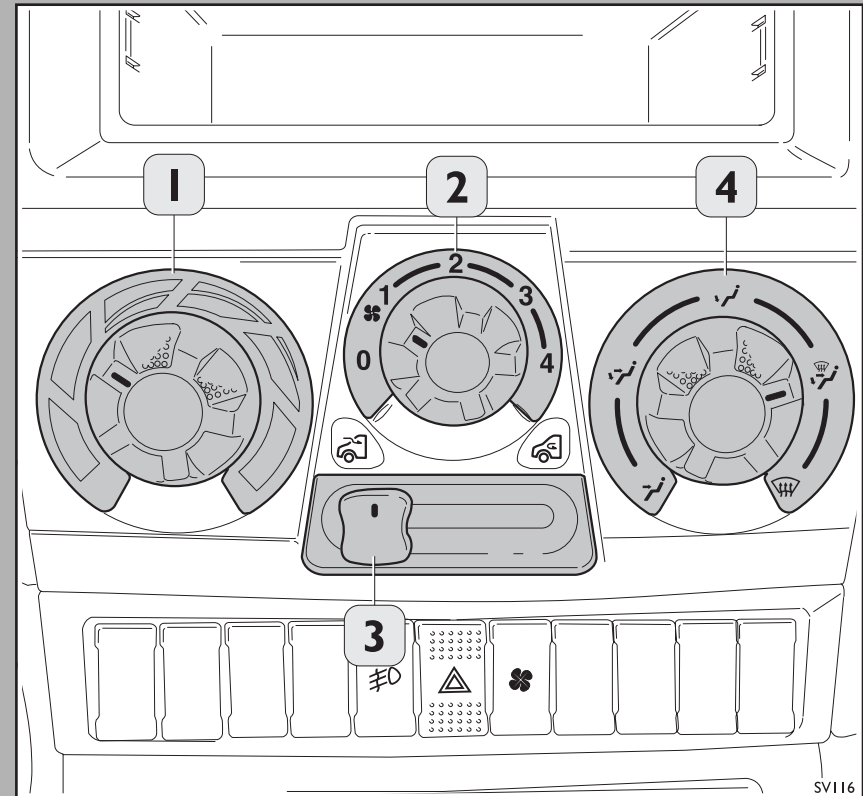

CONTROLS AND DEVICES

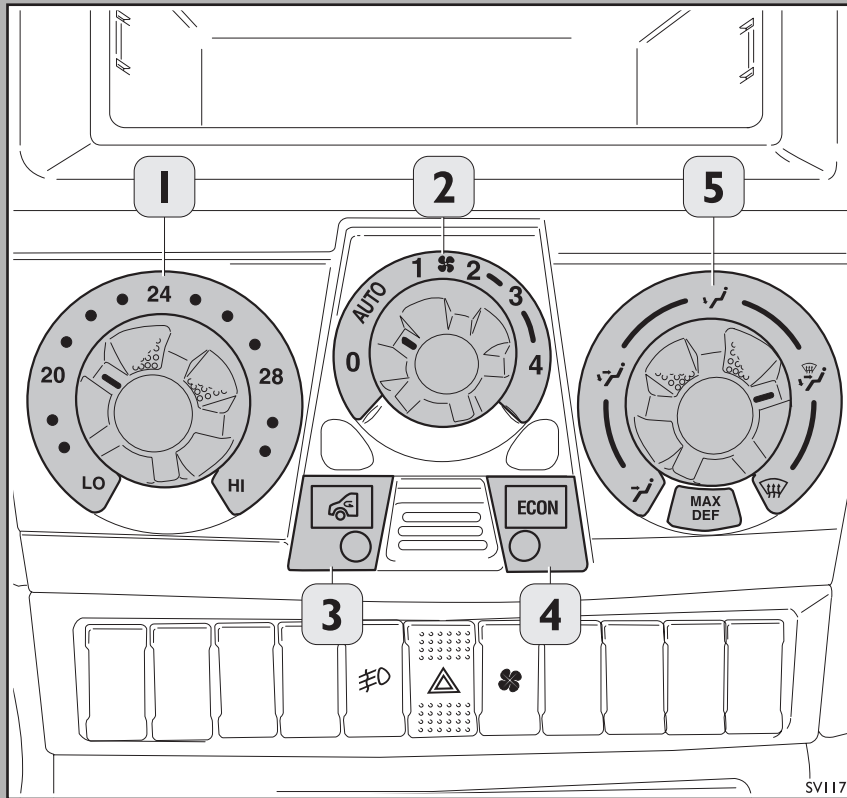
**Automatic climate control** (if provided)

1. Air temperature control knob with extreme positions for activating the HI and LO functions (max. and min. air temperature).

2. Electric fan knob with operating speed and manual/automatic/off mode selection.

3. Air recirculation switch: to prevent outside air from entering.

4. Air conditioner switch. The system is equipped with a pollen filter to clean the intake air: change it after approximately 20,000 kilometres or one year of use.

5. Air distribution control:

- face vents.
- face and feet vents.
- Air supply foot area.
- windscreen area and feet area air.
- screen vents.
- MAX/DEF position: the system prepares for defrosting/demisting.

Automatic system standard in Australian version Daily 4x4



- > Do not tamper with the conditioner circuit, risk of injury: the cryogenic liquid is pressurised and may cause freezer-burn if it comes into contact with the skin.

Warnings:

- One of the key functions of the air conditioner is air dehumidification. It is advisable to use it to avoid possible misting.

The system uses R134a coolant which is environmentally friendly in case of leaks.

Never, under any circumstances, use R12 fluid (or other fluids) incompatible with the system components, and containing CFCs (chlorofluorocarbons).

- During the winter the air conditioning system must be operated at least once a month for 10 minutes.
- The air conditioner automatically starts as soon as the engine is started: if you do not want it on, turn it off with the ECO button.

Recirculation function

This function is particularly useful in case of heavy pollution conditions (in a queue, inside a tunnel, etc.), and when quicker heating is required for the cab. Extended use is therefore not recommended, in particular with a passenger on board. Note: Do not use the recirculation function rainy/cold weather, otherwise the windows could fog up.

External temperature lower than 24°C (normally in external air intake)

The recirculation button with LED off indicates that the system is on external air intake.

To obtain manual recirculation it is necessary to press the button for less than 2 seconds. This condition is signalled with the LED of the button in blinking mode. To turn off manual recirculation it is sufficient to press the button again or wait for 30 minutes, after which the system will automatically go back into the condition of external air intake.

External air temperature higher than 28°C (normally on automatic recirculation)

Within 2 minutes of reaching the temperature of 28°C, the system goes onto automatic recirculation with the LED on steady (automatic recirculation comprises a cycle of 7 minutes on recirculation and 30 seconds on outside air intake). To obtain manual recirculation it is necessary to press the button for less than 2 seconds. This condition is signalled with the LED of the button in blinking mode. To turn off manual recirculation it is sufficient to press the button again or wait for 30 minutes, after which the system will automatically go back into the condition of automatic recirculation (LED on steady). To obtain external air intake it is necessary to press the button for longer than 2 seconds. This condition is signalled with the LED of the button off. From this state it is possible to pass from the condition of manual recirculation (LED on blinking) by pressing the button for less than 2 seconds or waiting 60 minutes and the system will automatically go back into the condition of automatic recirculation (LED on steady). If the ignition key is turned OFF and then ON the system will automatically go back into the condition of automatic recirculation (LED on steady).

NB: With the temperature between 24°C and 28°C, the control unit will manage one of the two described logics. It is anyhow possible to activate one of the two logic elements manually as directed in the above section.

Independent supplementary heater (if provided)

General Information Not available in Australia

The vehicle can have an additional heater, which can be selected accurately from 1 minute to 24 hours.

It is possible to program three different times for turning on, of which however only one can be activated each time. The duration of the operation can be selected between 10 and 60 minutes.

Control

When using the clock controls, remember that when the symbols are blinking fast you are in adjustment mode. If no button is pressed for five seconds the displayed time is saved. If buttons 8 or 3 are pressed for longer than two seconds, fast back/forward mode is on.

To apply it

Manual: by operating the immediate heating button 6.

The display will show the duration and the symbol for the heating mode 9. The duration stops being displayed after 10 seconds.

Automatic: at the time of activation of programmed heating or ventilation (if provided). The display shows the program number and the symbol for the heating mode 9 or ventilation 2 (if provided).

Turning off

Manual: by operating the immediate heating button 6.

Automatic: with the programmed limitation on operation duration. At the end of the duration, the display goes off.

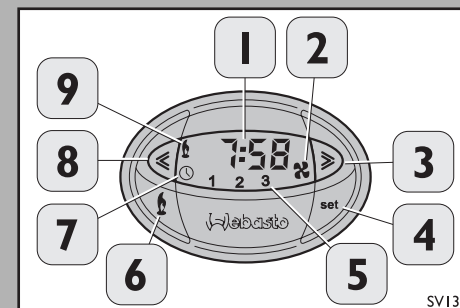

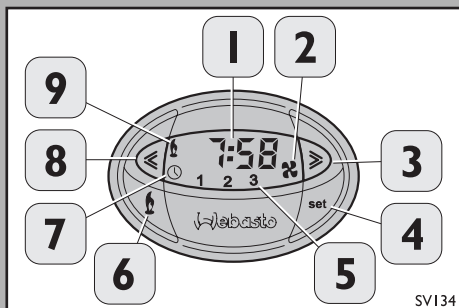

Time setting

This function is not available with heating mode on.

Keep button 4 pressed: at the same time, operate button 3 (Forwards) or 8 (Back).

Release button 4.

The time is displayed and the clock symbol 7 blinks.

Set the time with button 3 (Forwards) or 8 (Back).

The set time is saved with the display turning off or by pressing button 4.

Questioning the set time

Operate button 3 (Forwards) or 8 (Back).

With the heating mode on, the remaining operating time is displayed.

Change mode (if provided on the version)

Operate key (4).

Operate button 4 a second time and keep it pressed.

The last mode selected (heating 9 or ventilation 2 - if provided) is displayed.

Programming start of heating

Operate key (4). Within ten seconds operate button (3) (Forward) or (8) (Back), until the required time for starting heating is shown on the display. If you want another program number, press button 4 within ten seconds.

Factory settings:

Pre-selected time 1: 06:00

Pre-selected time 2: 16:00

Pre-selected time 3: 22:00

Important: The factory settings are cancelled with a new entry. The pre-selected times remain in memory until they are next changed. If the clock is disconnected (e.g.: when disconnecting the battery), the factory settings will be restored.

Turning off the pre-selected time

Briefly press button 4.

Selecting and activating the pre-selected time

Press button 4 within 10 seconds, until the program number with the required pre-selected time is displayed.

The pre-selected time you have chosen to set is automatically activated after approximately 10 seconds, with no need for additional confirmation by pressing another button.

The active mode (heating 9) and the program number blink until the heater starts working.

Important: Activate the pre-selected time taking account of the safety rules for heating with the vehicle parked that are stated in the specific box.

Heating when parked anyhow comes on at the activated pre-selected time, whether the vehicle is parked or running.

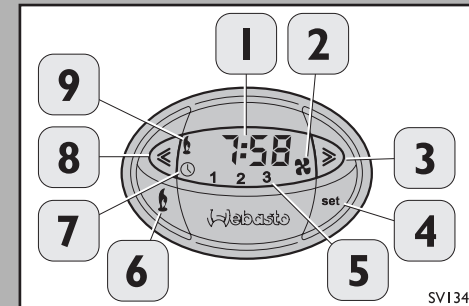

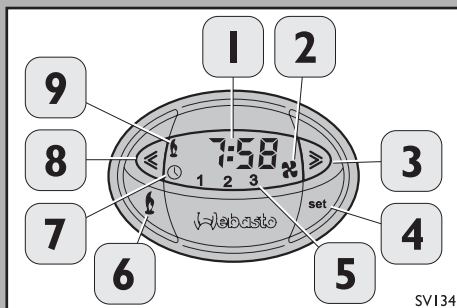

Setting the duration

Keep button 4 pressed. Press at the same time button 3 (Forwards) or 8 (Back).

Release button 4: the time and the clock symbol 7 are displayed.

Keep button 4 pressed again. At the same time press button 3 (Forwards) or 8 (Back).

Release button 4: the set duration is displayed and the heating symbol 9 blinks.

Set the duration with button 3 (Forwards) or 8 (Back).

The set duration is saved with the display turning off or by pressing button 4.

Setting the remaining operating time

In heating mode the remaining operating time can be modified for a variable duration of between 10 and 60 minutes with buttons 3 (Forwards) and 8 (Back).



CONTROLS AND DEVICES

> CAUTION!

- Pay attention to the summer/standard time setting.
- Even though to a lesser extent, the heater burns fuel just like the engine, so to avoid any possible intoxication and asphyxia the additional heater must never be turned on, not even for short periods, in closed places such as garages or workshops that are not equipped with exhaust gas extractors, even with remote time selection systems.
- Always switch off the heater when filling up with fuel and in the vicinity of service stations, to avoid risk of explosion or fire. Switch it off moreover in places subject to the formation of vapours or combustible dust (for instance, deposits of flammable material, coal, sawdust or cereals).
- Never park the vehicle over flammable material such as paper, grass or dry leaves: risk of fire!
- The temperature near the heater must not exceed 120°C (e.g. during paint baking in a body shop). Higher temperatures could damage the electronic module components.
- During operation with the engine off, the heater draws power from the battery; it should therefore be operated for a sufficient period with the engine running, in order to restore the battery's correct charge.
- For maintenance and repairs, only turn to the Service Network and use only original spare parts.

Supplementary heater suction

- To avoid vehicle stops due to lack of fuel, supplementary heater suction is inhibited when the tank is near reserve.

Maintenance

Have the additionally heater checked periodically (anyhow at the start of each winter) by the *Service Network*. This will ensure safe and economic operation of the heater and also its long life.

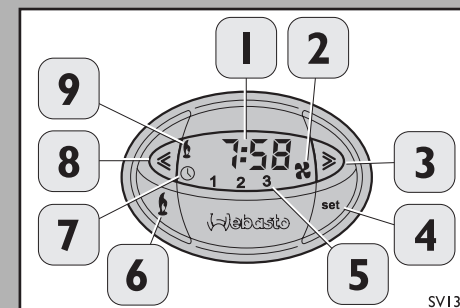

Accessories fitted by the user

Regarding the line of high quality products offered by the Iveco shop, please comply with the following advice:

- In case of additional drilling (e.g. hole for radio aerial) on the cab panelling, suitably protect the part concerned, to prevent early oxidation on internal or external surfaces.
- Take care when fitting (knocks by screwdriver, interference, etc.), to avoid permanent damage to the paintwork.

Attention: Disconnect the battery negative pole and then the positive before carrying out any work on the vehicle.

Self-adhesive decals

The removal or application of self-adhesive decals must not be done with sharp tools (e.g. blades, knives, etc.) as they could cause deep scratches on the paintwork, resulting in early corrosion under the film.

Radio transmitters and mobile phones

Mobile phones and other radio-transmitter devices (e.g. CB) cannot be used inside the vehicle unless a separate antenna is fitted on the outside of the vehicle. The use of mobile phones, CB transmitters or similar equipment in the driver cab (without an external antenna) generates electromagnetic fields at radio frequency that, when amplified by the effects of resonance inside the cab, may be harmful to health and can impair the operation of the electronic systems installed on the vehicle, including the engine control units, the ABS unit, etc. This can impact negatively on safety of both the vehicle and the driver.

Also, the transmission and reception efficiency of these devices may be degraded by the shielding effect of the coachwork.

Installation of additional electrical equipment

Do not install additional electrical/electronic equipment not provided for by IVECO or illegal (e.g. C.B. equipment. with powers above the legal limit of 5 W, which could cause noise or electromagnetic interference.



Installation of accessories, < additions and modifications to the vehicle must be carried out in compliance with the IVECO assembly directives (the specific publication "Directives for conversion and setups" is available from the Service Network workshops). IVECO authorisation is required for any exception to the assembly directives. Failure to comply with the above prescriptions will invalidate the warranty.

Starting and driving

To ensure that you get the best results out of your vehicle and that it runs efficiently for many years, we recommend that you do not run the engine at maximum power for the first 1,500 km. This section provides information on how to carry out the following operations as well as details about the related devices:

Vehicle keys	152
Immobilizer	153
Key switch positions	156
Starting the engine	159
Starting the engine at low temperature	162
EDC indicator light (fault diagnosis)	163
Central locking	164
Centralised locking + electronic alarm	165
Service brake - parking brake	170
Changing gear	172
Reduction unit - Transfer gear	173
Differential lock	174
ABS	176
speed programmer (Cruise Control)	178
Power take-off	182
Safe driving	183
Off-road driving conditions	189
Economical, environmentally-friendly driving	190

STARTING AND DRIVING

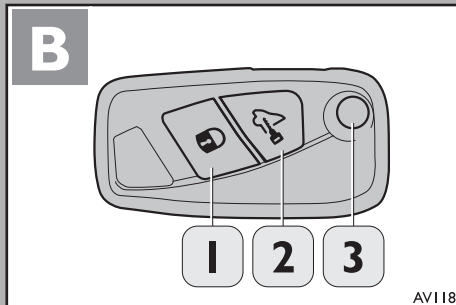
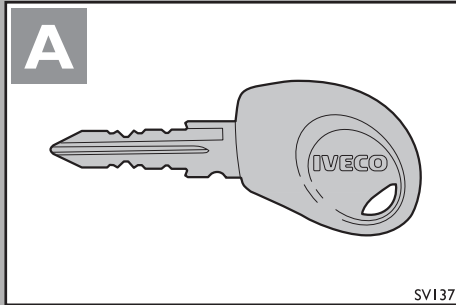
**Vehicle keys**

- A. Versions without central locking.
 B. Versions with central locking.
1. Total locking.
 2. Opening front doors.

The key has a metal insert that can be removed with the servo-assisted operation of the button (3).

To refit the metal insert in the key grip, keep the button (3) pressed and turn it until it clicks in place.. Release the button (3) after locking.

Version B

Central locking system standard in Australia



- Press button 3 only with < the key held away from the body, the eyes in particular; and from items liable to be damaged (such as clothing). Never leave the key unattended, to prevent anyone, particularly children, from tampering with it and inadvertently pressing the button.

STARTING AND DRIVING

Immobilizer (if present)

To improve protection against thieves, the vehicle is equipped with an electronic engine immobiliser. In fact the ignition keys are equipped with an electronic device that transmits a coded signal to the immobiliser control centre.

Vehicle keys

The keys are supplied in pairs and form part of a set (keys+EDC).

Code Card

A code card containing the following information is supplied with all the keys:

- a.** the electronic code for emergency starting. Contact the *Service Network* to activate the code.
- b.** the mechanical code of the keys;

users are advised to carry the electronic code recorded on the code card with them at all times in case the need for an emergency start-up should arise.

Immobiliser system standard in Australia

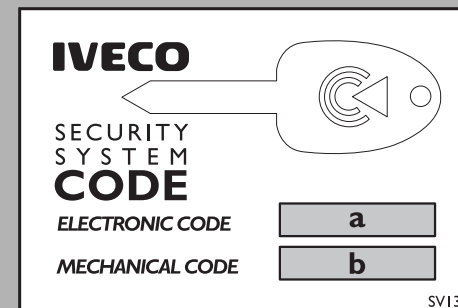

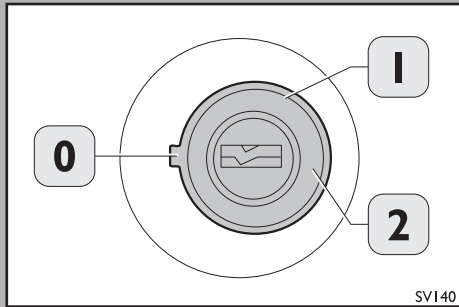

SVI40

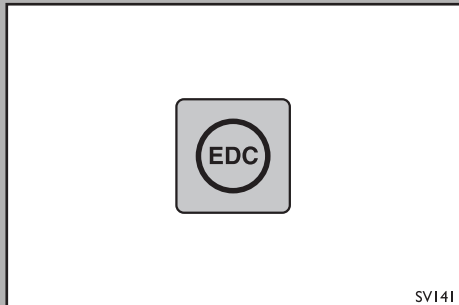

SVI41

Emergency start-up

It allows starting the engine when the key cannot be recognised or the Immobilizer control unit has a failure. Starting is possible by entering the electronic code with the accelerator pedal by carrying out the following procedure:

- key in position (1).
- EDC warning light begins to flash after 2 seconds.
- Press the accelerator pedal fully down for 5 to 12 seconds.
- The warning light begins to flash at a lower frequency.
- When the number of flashes corresponds to the first digit of the electronic code, press the accelerator pedal fully down and release it (the warning light remains off while the pedal is pressed); continue reading and operating the accelerator pedal for the remaining numbers of the electronic code.
- If the code entered is correct, the warning light stops blinking, otherwise repeat the procedure. In any case, contact the *service network* as soon as possible for verification of the system.

STARTING AND DRIVING**NB:**

Each key supplied has a common mechanical code and a unique electronic code, which must be stored on the control centre of the system. When additional keys are requested, remember that the code is recorded on all the keys, including those already in your possession. Contact the *Service Network* directly and be prepared to produce all the keys in your possession and the Code Card. The codes of keys not presented during the new memorisation process are erased from the memory; this ensures that any lost keys will no longer be able to start the engine.

NB:

- The Code Card is an essential and unique element associated with each vehicle; it is thus recommended to keep it in a safe place. It is therefore advisable to note down the codes and to avoid leaving it in the vehicle and to move it frequently in order to avoid risk of loss.
- If vehicle ownership changes, it is essential that all the keys and the code card are handed over to the new owner.

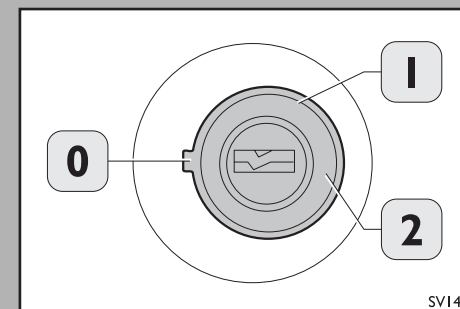

STARTING AND DRIVING

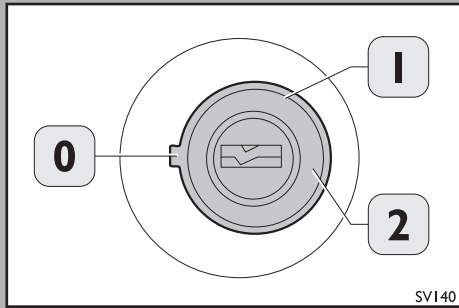
**Key switch positions**

- 0. = Insertion and extraction of the key - engine off - steering lock, Immobilizer on.
- 1. = Predisposition for engine starting - various indicators, Immobilizer off.
- 2. = Starting the engine.



Risk of accident: In case of tampering with the ignition switch (e.g. attempted theft) it is advisable to have the device checked by the *Service Network*: risk of locking the steering wheel while driving.

STARTING AND DRIVING**Immobilizer recognition**

Turning the ignition key to position (1) deactivates the immobilizer only if the protection system recognises the code transmitted by the key.

If the code is valid, the control centre of the protection system sends an appropriate codified signal to the electronic control unit of the engine enabling the starting of the engine.

Warning light 3 on = no key recognition.

Warning light 3 off = key recognised.

Now return the key to position (0) and then turn to position (1) again; if the immobiliser is still active, try again using the other key supplied.

If you are still unable to start the engine, contact the *Service network*.

Enabling immobiliser system

It is activated when the ignition key is turned to position (0):
engine stopped, key can be removed.

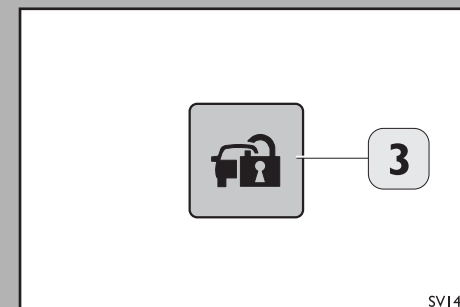
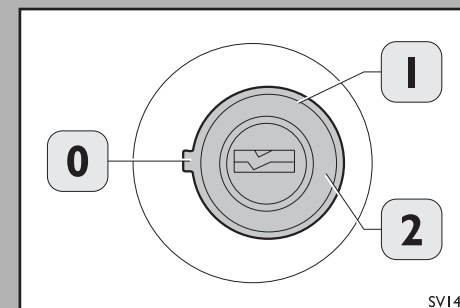

STARTING AND DRIVING

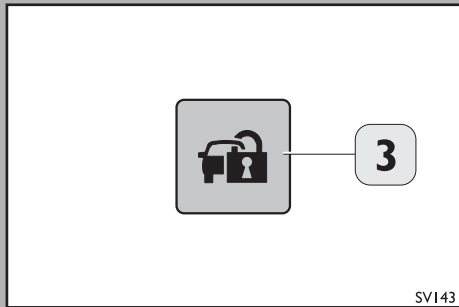
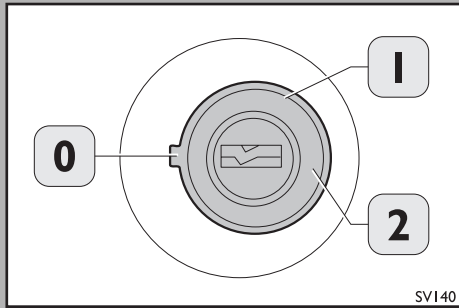

The warning light (3) coming on approximately two seconds after starting the vehicle does not necessarily mean there is a fault with the system, but in certain cases it highlights a situation that can be interpreted as attempted tampering by a thief, or a particularly low battery charge status.

If this occurs, in order to do a system test it is necessary to stop the vehicle, switch off the engine and turn the key to position (0); turn the key to position (1) again; the warning light (3) will come on and must go off after approx. 1 second.

Should it remain on after this last procedure, repeat the operation, waiting in position (0) for more than 30 seconds. If after this attempt the warning light stays permanently on when the key is in position (1), immediately contact the *Service Network*.

Follow the directions/warnings related to the Immobilizer system, which are shown on the display (where applicable).



> Before starting the engine in closed premises, make sure that they are adequately ventilated, since the exhaust gases are toxic.

Starting the engine

- Insert the key in the ignition switch and turn it clockwise to the position (1).
- If the vehicle has manual transmission, make sure the gearbox is in neutral or press down the clutch pedal.
- Then turn the key to the position (2) and release it as soon as the engine starts, **without pressing the accelerator pedal**. (If this is not done, a puff of black smoke when starting is considered normal).
- If the engine fails to start immediately, do not operate the starter motor for more than 30 seconds. After starting the engine, drive slowly with the engine at medium rpm to allow it to reach the optimum running temperature.

In this way, you achieve:

- a continuous and regular flow of oil in the entire lubrication circuit.
- exhaust emissions maintained with specified limits.
- fuel consumption kept low.

STARTING AND DRIVING

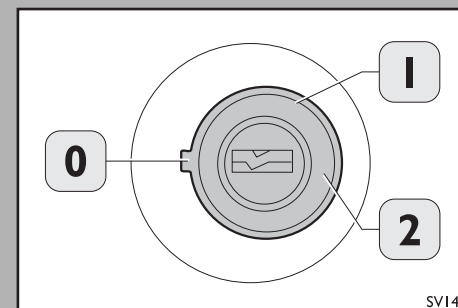

STARTING AND DRIVING

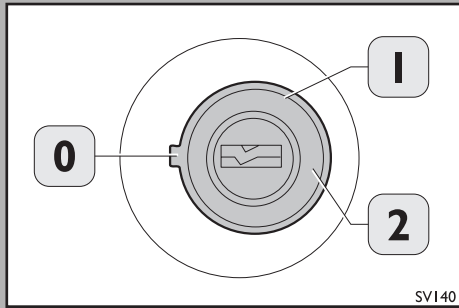
**Key switch positions**

- 0. = Insertion and extraction of the key, engine stop, steering wheel lock.
- 1. = Preparation for engine start - various signalling.
- 2. = Starting the engine.

**CAUTION!**

- To reduce harmful emissions, avoid leaving the engine idling, hot or cold, for long periods.
- Act immediately in case of excessive smoke from the exhaust, as it can cause damage to the environment and the engine. A first step is to change the fuel filter cartridge. If necessary, have the fuel injection system checked by specialised personnel. To obtain maximum benefits from these operations, use original Iveco cartridges for replacement; for work on the injection system contact the *Service Network*.
- Never in any case exceed the engine speed of 4500 rpm.



- > • **Risk of accident:** extract the key from the ignition lock only when the vehicle is stopped. Never leave the vehicle without applying the parking brake.

Engine stop

To stop the engine turn the key to 0.

STARTING AND DRIVING

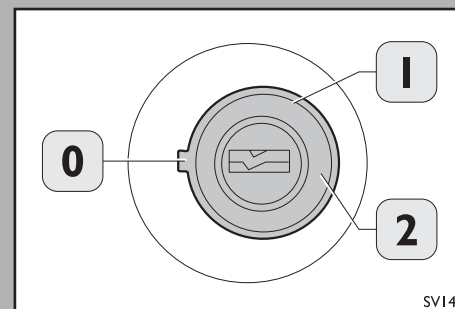

STARTING AND DRIVING

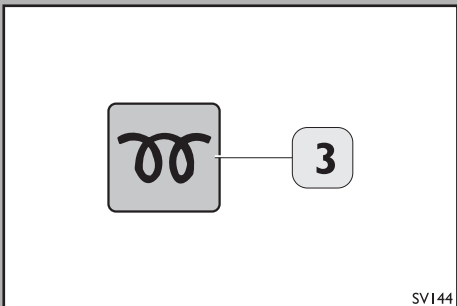
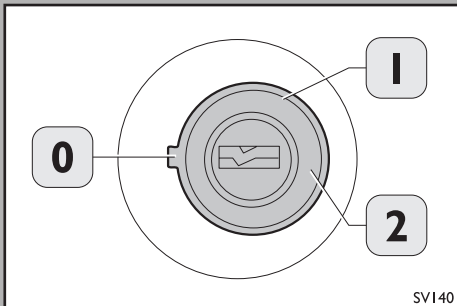
**Starting the engine at low temperature**

- Insert the key in the ignition switch and turn it clockwise to the position (1).
- Fully depress the clutch pedal.
- Wait for the warning light 3 (glow plug preheating) on the dashboard to go out.
- Start up by turning the key to position (2), **without pressing the accelerator pedal.**

Checking faults by means of EDC warning light (diagnostics)

It is possible to get information regarding faults and load on the fuel injection system by means of the EDC warning light(1). If the warning light comes on during the normal operation of the vehicle, it indicates the possible occurrence of a fault:

Warning light off	Normal operation	
Indicator on fixed	Serious fault Functional deterioration of the system.	Drive carefully to the nearest <i>Service Network</i> repair shop.
Light blinking	Very serious fault Functional deterioration of the system. Loss of one or more safety functions, and possibly engine STOP.	<ol style="list-style-type: none"> 1. Park the vehicle by the side of the road. 2. Contact the dealer or, outside opening hours, call the toll-free number for the Customer Center (24 hours service), 3. Take the vehicle to a <i>Service Network</i> repair shop.

On some versions the EOBD warning light (2) may come on at the same time as the EDC warning light (1).

This warning light comes on to signal malfunctioning of parts of the engine or exhaust system that affect emissions directly. The same requirements/warnings already mentioned for the EDC warning light apply to this warning light too.

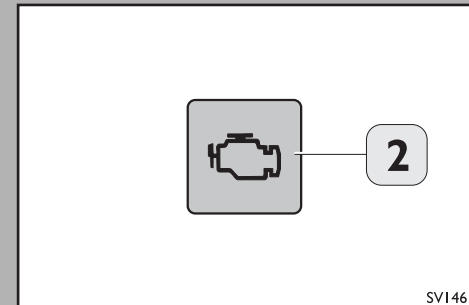
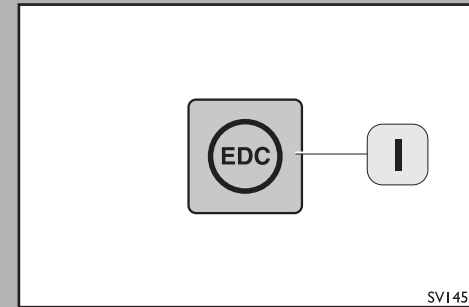

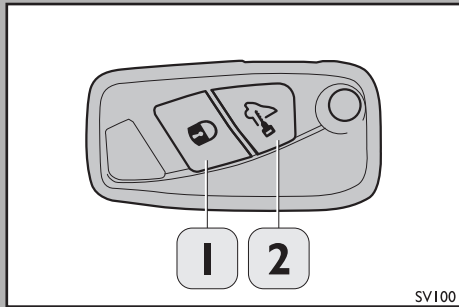

Central locking (if provided)

Briefly press button 1 in the key, pointing it in the direction of the vehicle: the direction indicators will flash once to signal that all the doors have been locked.

Always point the key towards the vehicle and press button (2) to unlock the doors; the direction indicators will flash twice to signal that all doors have been unlocked.

- Central locking can only be activated with the remote control.
- unlocking or locking the doors with a key does not bring the central locking into operation.
- Repeatedly using the remote control at close range inhibits its operation for another 30 seconds in order to prevent the system actuators from overheating.

1. Total locking.
2. Opening front doors.

Centralised locking + electronic alarm (if provided)

In combination with central locking, the vehicle can be equipped with an electronic alarm performing the following functions:

- remote operation of centralised door locking/unlocking (see previous page).
- Perimeter surveillance, signalling of any opening of doors, and bonnet.

When the system is turned on, the electronic alarm triggers if:

1. One of the doors or the bonnet is opened.
2. The battery is disconnected or the alarm power supply leads are cut.

The system is composed of:

- a system control unit (located in the area of the heater controls under the dashboard).
- A microswitch on each door of the vehicle and on the bonnet to signal opening.
- A self-powered siren located in the engine compartment.

**Electronic alarm system available as option for Daily 4x4;
only in conjunction with central locking system**

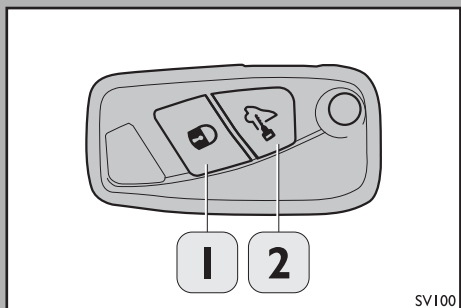
STARTING AND DRIVING

To turn on the alarm, briefly press button 1 in the key, pointing it in the direction of the vehicle: the indicators will flash once to signal that all the doors have locked and the alarm system has been turned on.

To switch off the alarm, press the button (2), always pointing the key towards the vehicle: the indicators will flash twice to signal that the doors are locked and the alarm system has been deactivated.

STARTING AND DRIVING

- The alarm system is connected to the vehicle's Immobilizer system.
- If the siren inadvertently started, it can be silenced not only by operating the remote control again, but also by turning the ignition key onto position (1). Therefore bear in mind that the electronic code on your Code Card applies not only for the Immobilizer; but also to manage problems concerning the alarm in the *Service Network*. For the Code Card the same recommendations therefore apply as found in the paragraph on the Immobilizer.
- Repeatedly using the remote control at close range inhibits its operation for another 30 seconds in order to prevent the system actuators from overheating.

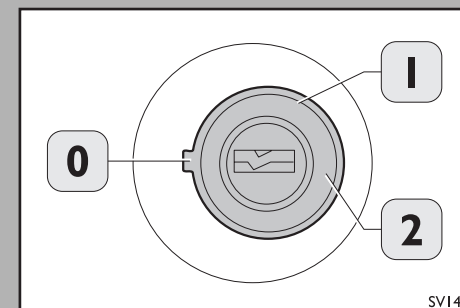

STARTING AND DRIVING

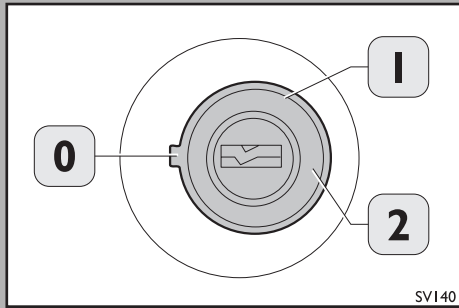

Changing vehicle battery (procedure only for vehicles equipped with electronic alarm)

- Open the bonnet and prepare the battery positive lead for disconnection, BUT WITHOUT DISCONNECTING IT.
- Get back into the cab, turn the ignition key to position (0) and IMMEDIATELY turn it to position (1).
- **From now on you have 15 seconds to disconnect the vehicle battery positive cable.**
- If disconnection occurs more than 15 seconds after the operation described above (0) - (1) - (0) performed with the key in the ignition, the siren will sound since it is self-powered with its own backup battery. In this event, reconnect the battery positive cable and repeat the entire operation.



The batteries contain substances that are very hazardous for the environment. To replace batteries, it is advisable to contact the Service Network which is equipped for battery disposal in respect for the environment and in compliance with the regulations.



> A flat key remote control battery is harmful for the environment. It must be disposed of in specific containers, as prescribed by the law. Or it can be sent to the *service network*, which will dispose of it properly.

Replacing the key remote control battery

To change the battery, proceed as follows:

- Press button 3 and move metallic insert 4 to opening position.
- Turn screw 5 using a fine-tipped screwdriver.
- Remove the battery box 6 and change the battery 7 respecting the polarities;
- Fit the battery box 6 back into the key and lock it by turning the screw 5.

STARTING AND DRIVING

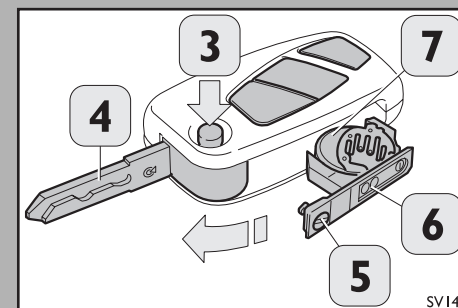

STARTING AND DRIVING**Main brake**

- With the engine switched off, no servo-assistance is supplied to the braking system, to brake it is therefore necessary to exert a greater force on the brake pedal.
- In the event of trouble with a braking circuit, the pedal travel will lengthen and it is necessary to apply a greater force on the brake pedal: Caution: The stopping distances are greater, have the system checked immediately by a garage in the *Service Network*.
- Respect the vehicle's maximum capacity and the value of the maximum permissible loads on the single front and rear axles in order to avoid abnormal stress with negative effects on the brakes.

STARTING AND DRIVING**Parking brake**

- To apply the parking brake, pull the lever upwards so as to give the device the necessary capacity according to the gradient of the ground and the load. (With the ignition key in position I the related warning light in the dashboard lights up).
- When an increase is noticed in the number of clicks for being able to park the vehicle correctly, have the system checked immediately at a garage in the *Service Network*.
- To disengage the parking brake, pull the lever slightly upwards, press the button and lower the lever completely, into the rest position (warning light off).
- Uphill or downhill, with a particular steep gradient, put a wedge (check) respectively either behind or in front of the wheels of the most laden axle (normally behind or in front of the rear wheels with the vehicle loaded, the front wheels with the vehicle unladen).

Note:

Use the parking brake only when the vehicle is stationary.

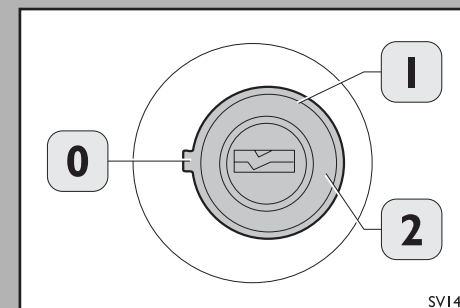

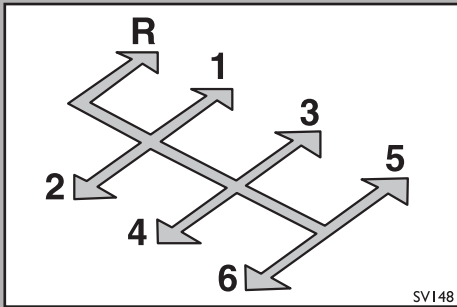

SVI48

Changing gear

Starting the engine

- Press the clutch pedal down and shift the lever into first gear.
 - Release the parking brake.
 - Slowly release the clutch pedal and gradually accelerate.
 - Proceed to engage the following gears.
- The engine must never exceed the rpm corresponding to maximum speeds, even downhill.

Stopping the vehicle

- Release the accelerator pedal and gradually press the brake pedal.
- When the vehicle is about to stop, disengage the clutch and shift the gear lever to neutral.
- With the vehicle stopped, apply the parking brake.

Attention: Avoid using the parking brake when the vehicle is moving.

To engage reverse gear from neutral, raise the ring under the grip (using the fingers of the same hand gripping the lever) and move the lever to the left and then forwards.



CAUTION!

Start the vehicle forwards always in first gear. Using any gear other than first, regardless of the vehicle load, considerably reduces the life of the clutch plate and related components. Do not rest your foot on the clutch pedal while driving, except when changing gear.



> **CAUTION!**

The vehicle must be stationary when engaging low gears.

Reduction unit - Transfer gear

Using low gears

The low gears must only be used when maximum power is required for step slopes, sandy or snow-covered ground or for the use of particular setups requiring slow speeds.

To engage the low gears shift the lever (1) in the direction of the arrow.

'Half gears'

When to use the 'half gears'

The half gears are useful when, with the vehicle moving, to maintain the required speed on engaging the lower gear the engine speed increases excessively, whereas on engaging a higher gear the engine speed decreases, with lower torque.

The half gears are useful when driving uphill with many bends or on rough roads with full load.

Use of 'half gears'

The half gears can be used with the normal gears and with the low gears. This obtains 24 ratios (6+6 ratios with the normal gears and 6+6 with the low gears).

The half gears are engaged with the vehicle moving by pressing the clutch pedal and shifting the lever (2) in the direction indicated by the arrow.

STARTING AND DRIVING

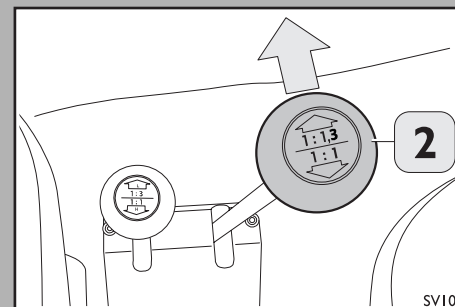
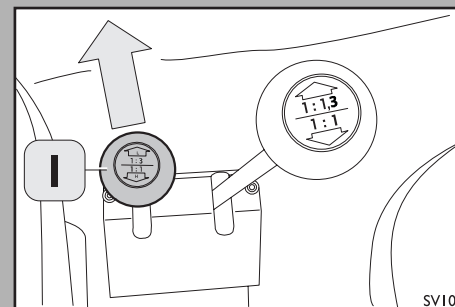

STARTING AND DRIVING

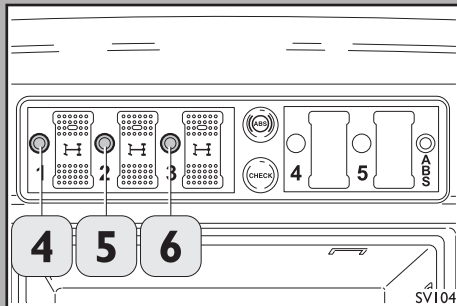
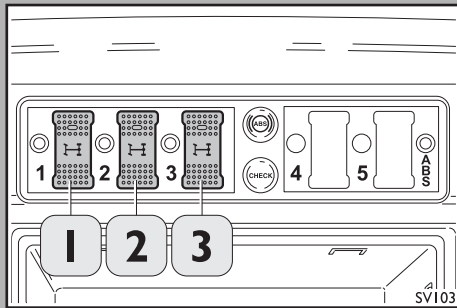
**Differential lock****Engagement logic**

To correctly engage the differential lock, press the buttons in the order indicated:

- Middle: 1;
- Rear: 2;
- Front: 3.

Lock engagement is signalled by the indicators:

4. middle lock;
5. rear lock;
6. front lock.

NOTE:

A warning alarm sounds only when all 3 differential locks are engaged.

**CAUTION!**

- Do not use the differential locks on routes with sudden bends or on asphalt.
- The differential lock must only be used off the road or on slippery terrain (mud, snow, etc.) and only for the time needed to get out of the emergency situation.
- In muddy and slippery conditions do not let the wheels slip when differential lock is not engaged: a few seconds are sufficient to cause serious damage.
- Do not engage the differential lock while a wheel is slipping; do not drive on pavement or on cobbled surfaces with the differential lock engaged: this could seriously damage the gears.
- Risk of accident: vehicle handling is limited with the differential lock engaged.



STARTING AND DRIVING

> **CAUTION!**

If the differential lock fails to disengage immediately, vary the driving direction in order to eliminate any stress.

To correctly engage the differential locks, proceed as follows

- Go to the locking position when the vehicle is stationary or at low speed.
- Proceed with caution.

For correct disengaging of the locks, once the negative road conditions have been overcome, proceed as follows:

- Pass to the unlocking position maintaining the speed of the vehicle.
- Take your foot off the accelerator pedal briefly.
- Resume the safe speed.

ABS Antilock Braking System (if provided)

Comply with the following:

- during the braking action, the brake pedal may be subjected to light pulsations due to the ABS system.
- The performance of the system, in terms of active safety, must not lead the driver to take pointless or unnecessary risks.
- Driving must in any case take into account the weather conditions, visibility and traffic.
- Maximum possible deceleration in any case always depends on the grip between the tyres and road surface. Bear in mind that in the event of snow or ice, the grip is greatly reduced and therefore, in these conditions, stopping distances remain high even with the ABS system.
- Lighting up of the ABS indicators + indicator (I) with the engine running indicates a system fault. In this case, hard braking can lock the wheels, with risk of the vehicle skidding. In all cases, drive the vehicle, avoiding sudden braking, to the nearest *Service Network* point for a system check-up.



Risk of accident: A failure of the ABS device modifies the braking behaviour of the vehicle.

Contact the *Service Network* as soon as possible, and drive with extreme caution.

STARTING AND DRIVING**ABS - Vehicles with rear differential lock**

Use of the differential lock is allowed within the speed limit of 15 km/h and only on straight stretches.

Warnings:

- The rear differential lock must only be used when really necessary on straight stretches and at speeds under 15 km/h. Improper use of this device can compromise the stability of the vehicle and cause mechanical damage.
- In particular road conditions, simultaneous use of the brakes and the differential lock can reduce the stability of the vehicle even in the presence of ABS.
- The differential locking device does not have automatic disengagement: follow the instructions for disengagement. Therefore to restore standard operating conditions it is necessary to stop the vehicle and release the button.
- If lock fails to disengage immediately on releasing the relevant button, vary the driving direction to eliminate any stress. Make sure the differential is unlocked before restarting.

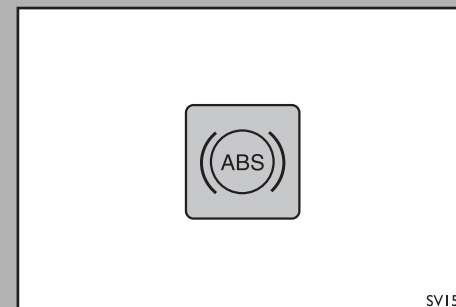

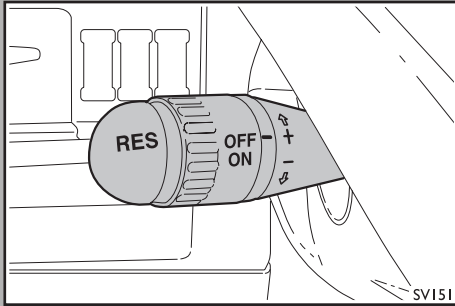
**Speed programmer** (Cruise Control-if provided)

The system automatically keeps the vehicle speed without using the accelerator pedal.

WARNING: The speed programmer function is active only if the clutch pedal is pressed once after starting the engine.

The Cruise Control must not be used in heavy traffic or when it is important to control the speed continuously (e.g. on hills).

It can be enabled when the following conditions are met:

- vehicle moving with gear engaged (1st gear excluded);
- vehicle speed higher than 30 km/h;
- brake pedal not pressed;
- clutch pedal not pressed.

[Cruise control standard on Daily 4x4](#)

STARTING AND DRIVING

The control is deactivated if the brake or clutch pedal are pressed. The same occurs if the minimum speed required is not reached. The maximum speed limit is stored in the program within the electronic control module and cannot be changed.

SELECTED POSITION	VEHICLE SPEED CONTROL
+	Speed increase
-	Speed decrease
RESUME	Selection of the last speed stored
ON/OFF	System activation

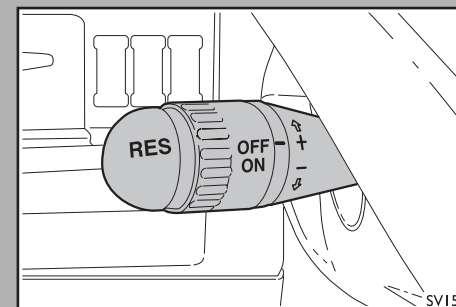

STARTING AND DRIVING

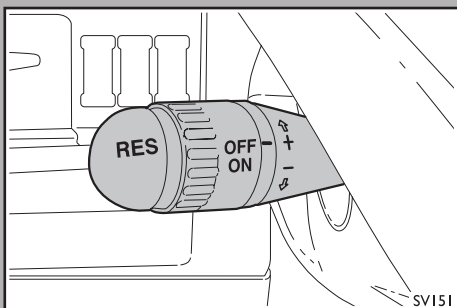

0. The position ON/OFF enables/disables the following functions:

1. The position + performs the following function:

a) selected just once, it activates the function and keeps the speed set by the current accelerator pedal position.

It is then possible to release the accelerator pedal; the vehicle will keep the cruise speed as set.

b) when the function already activated, the ON + switch serves to increase the vehicle speed without using the accelerator pedal.

2. The position - performs the following function:

a) selected just once, it activates the function and keeps the speed set by the current accelerator pedal position

b) when the function is active, it is used to decrease the vehicle speed.

3. The RESUME position has the following function:

enables the function and automatically adjusts the speed of the vehicle to the last saved value after the engine was started (last value set before switching off, compatible with the selected gear).

5. Tip Function

By briefly selecting the position + or - the vehicle speed changes by 1 km/h (for example, with a speed of 60 km/h, selecting position + three times obtains 63 km/h; selecting position - three times obtains 57 km/h): it is necessary to reach the first set speed before performing this operation. .

STARTING AND DRIVING**Turning off**

The system is disengaged:

- **manually** and permanently by selecting OFF
- Automatically **and permanently by pressing the brake or clutch pedal.**
- **Automatically** and permanently by pressing the accelerator pedal (thus requesting a higher speed) for more than 3 minutes if the Cruise function is enabled (ON position).

After switching off, it is possible to bring the vehicle back to the cruise speed set previously by simply selecting the RESUME position. The system is temporarily disabled with the accelerator pedal (for no longer than 10 seconds), when a speed greater than the set limit is required. As soon as you release the accelerator pedal, the function automatically resumes the last saved speed.

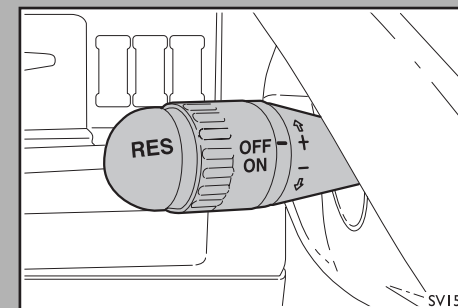

STARTING AND DRIVING

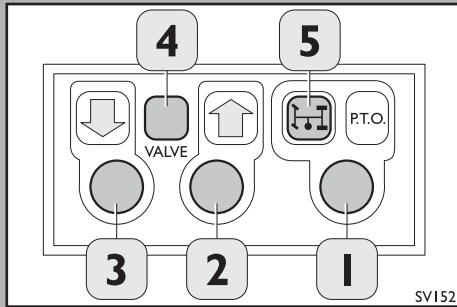

Up to 5 different PTO solutions are optionally available for Daily 4x4; enquire with your dealer

PTO (if provided)

For optimal use of the power take-off it is necessary:

- With the vehicle stationary, bring the engine speed to idling, **enable Cruise ON, press the clutch pedal**, wait 4-5 seconds, after which operate the engagement command with button (1). LED 5 comes on to signal engagement.
- **Release the clutch pedal very slowly.** The engine speed automatically goes to a value of 1100/1200 rpm. Then bring the engine speed to the correct value to use the system with the + and - buttons of the cruise control so as to increase/decrease the engine speed or use the RESUME button to retrieve the last saved engine speed, ensuring that the user is not working.
- To disengage the PTO, press the clutch pedal.

CAUTION! The engagement controls using the pushbuttons are delayed to ensure operation is on purpose.

1. PTO engagement button.
2. Dump body up button.
3. Dump body down button.
4. LED signalling body moving.
5. LED signalling PTO engaged.

STARTING AND DRIVING

> **CAUTION!**

Risk of accident: Do not leave objects in the vehicle that could shift and hinder the controls or strike the occupants in case of a collision.

Safe driving

Before starting

- Adjust the seat and rear vision mirrors to obtain a correct driving position.
- Check that nothing is obstructing the movement of the pedals (the brake pedal in particular).
- Check horn operation.
- Check the external lighting and, if necessary, clean the lenses.
- Check that beam alignment is set correctly, particularly for night driving.
- Check for any leaks of oil or other fluids under the vehicle.
- Check that the possible load is correctly stowed.
- Lastly, check that the handbrake is released and that the warning lights on the dashboard are not indicating any faults. Release the handbrake with the brake pedal pressed to prevent the vehicle from moving accidentally.
- Fasten the seat belts correctly.

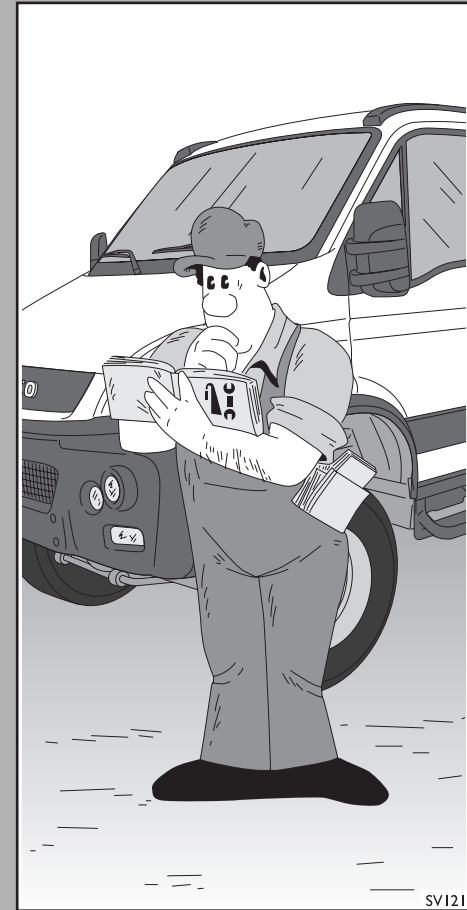

SV121

STARTING AND DRIVING**Driving**

- Long journeys should be undertaken only when the driver is in optimum form.
- A light meal, based on easily digested food, will help keep reflexes ready and ensure the concentration necessary for safe driving.
- Abuse of alcohol, drugs and/or certain medicines is very dangerous. Never drive under the influence of alcohol or the effect of drugs or narcotics.
- Careful driving also means being in a position to predict the careless or incorrect behaviour of others, keeping to the speed limits and using the correct lane when on the motorway.
- Use the indicators when changing direction.
- Keep a safe distance from the vehicle ahead; this distance varies depending on speed, weather conditions and traffic and road conditions.
- Do not drive with a hand on the gear lever; the unintentional force (if even light) applied will cause pointless wear on the parts inside the gearbox.
- Do not drive with the gearbox in neutral.
- Do not drive with a foot on the clutch pedal; this habit can cause early wear of the clutch components.
- Do not drive for too long without a break; stop at regular intervals to stretch legs and freshen up.

STARTING AND DRIVING

- Use the many settings of the heating and ventilation or climate control system to ensure a constant air change.
- To drive downhill, proceed as follows: in these conditions the power-assisted braking and the braking effect supplied by the engine are not available, and a greater force is required in pressing the brake pedal: use low gears so as not to overheat the brakes.
- In case of stopping due to breakdown, park the vehicle off the road, switch on the emergency lights and arrange the triangle to signal the presence of the vehicle. Always comply with the current road regulations.
- Do not apply decals or other stickers on the windows: they may distract or obstruct vision.
- Throwing burning objects such as cigarette ends out of the windows when the vehicle is moving could be dangerous for persons, for other vehicles, for the surrounding environment and for the goods being carried. It could also be hazardous for the vehicle itself.

Parking

When leaving the parked vehicle, proceed as follows:

- Switch off the engine.
- Engage the parking brake.
- Engage first gear if the vehicle is on an upward slope or reverse if on a downward slope.
- With the engine off, do not leave the ignition key in the position (I), to avoid unnecessary current absorption from flattening the battery.

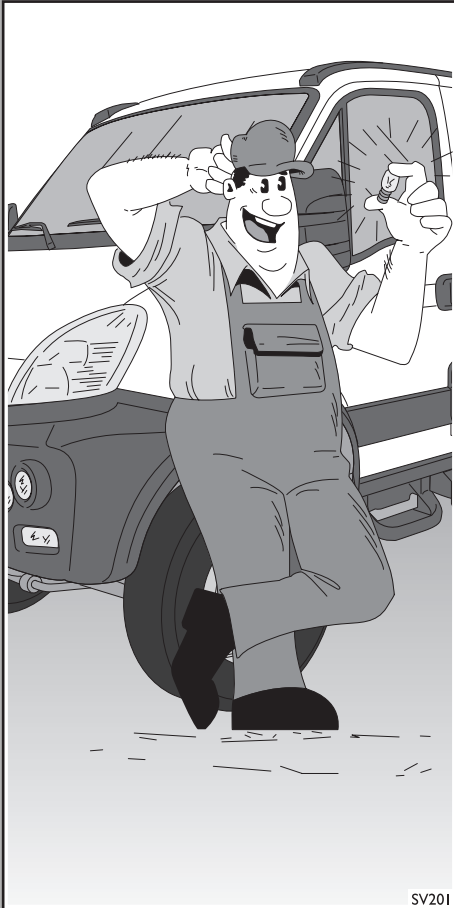

Night driving

- Drive with particular care, when necessary reducing the speed, in particular on unlit roads.
- Keep a longer safety distance compared to daytime driving: in fact, it is more difficult to judge the speed of a vehicle when seeing only the lights.
- Stop and rest at the first signs of sleepiness: to continue would be dangerous for you and for others.
- Only use high beam outside built-up areas and when you are sure that it will not disturb other motorists.
- Switch from high beam to low beam when crossing other vehicles.

Driving in rain, fog and snow

- If the road is wet, wheel grip on the road surface is considerably reduced, therefore stopping distances increase and road holding in bends decreases: reduce the speed and keep a greater distance from the vehicles ahead.
- Heavy rain and fog reduce visibility; in compliance with the current local regulations, switch on the low beams even during the day to make the vehicle more visible.
- Do not drive through puddles or sections of flooded road at high speed; aquaplaning can cause loss of control of the vehicle: mainly use the engine brake and avoid sudden braking.
- If outside visibility is reduced, position the ventilation controls as shown in the special section, to ensure efficient demisting of the windows.

STARTING AND DRIVING

- Before starting out, check the windscreen wiper blades; if the temperature drops below 0°C, or in case of snow, make sure the blades are not stuck to the windscreen.
- In case of fog, drive very carefully, limiting the speed and possibly avoiding overtaking.
- Make sure the detergent liquid contained in the windscreen/headlight washer reservoir has antifreeze and antiscaling properties.
- During winter periods, even apparently dry roads may have icy sections: in particular, where not very exposed to the sun or flanked by trees or rocks.

TYRES

The tyres fitted to the vehicle are the “tubeless” type. You are advised to comply with the following requirements in order to achieve maximum driving comfort, safety and long tyre life:

- With new tyres, do not drive at maximum speed during the first 100 km.
- Before tight bends, reduce the speed even if vehicle performance allows otherwise.
- avoid sudden acceleration or over-abrupt braking.
- Do not drive for long periods at high and constant speed, especially on rough ground.
- Make sure the wheels are correctly balanced and aligned.
- Avoid knocking the sides of the tyres (for example, when parking).
- do not tamper with the inflation valve.
- Do not attempt to insert tools between the tyre and rim.
- replace the rim in case of any warping.
- in case of an anomalous decrease in pressure, replace the wheel and have its tightness checked.



- Tyre pressure, including the spare wheel, must be that specified in the special section of this handbook.
- Do not use worn tyres, of unknown origin or more than 6 years old.
- Inner tubes must never be used with tubeless tyres.
- Avoid leaving the vehicle parked for long periods on the edge of a step or other uneven parts of the road surface.
- Check the tyre tread regularly, respecting the minimum amount required by the law. Some types of tyres have wear indicators; and must be replaced as soon as they become visible on the tread. Tread wear increases the risk of aquaplaning.
- Regularly check the tyres for uneven tread wear; if necessary, contact the *Service Network*.

Snow chains

- The use of snow chains is subject to current legislation applying in each country.
- The chains must be fitted to the drive wheels only.
- To prevent tyre damage, do not drive on roads that are not covered with snow with the chains fitted. In extreme circumstances (for example, in tunnels), proceed very slowly and remove the chains as soon as possible. With the chains fitted, keep to a moderate speed, avoid holes in the road and do not mount steps or pavements.
- For some types of chains, the tension has to be re-checked after travelling a few dozen metres.
- Before buying or using snow chains, consult the *Service Network*, which may be able to provide you with more information on how to choose and use the products available on the market for coping with snow.



> **CAUTION!**

To prevent serious damage to the vehicle:

before crossing a ford, switch off the engine radiator fan by pressing the button (1). A warning buzzer will signal this operation. After crossing the ford, switch the fan on again by pressing the button (1).

Activation is signalled by the buzzer going off.

Off-road driving conditions

- Pay attention during off-road driving and avoid dangerous areas.
- Do not drive crosswise along steep slopes. Follow a straight line downwards.
- Reduce the speed in case of strong cross-winds.

Rules to follow for fords

Before entering the water to cross a ford or flooded zone, take these precautions:

- Make sure the ground is even, firm and free of obstacles.
- If the current is strong, cross diagonally with the current.
- Engage the differential lock and first or second low gear, keeping the engine at medium speed.
- After crossing a stream, ford or muddy stretch, press the brake pedal gently several times at low speed to eliminate any moisture present.

STARTING AND DRIVING

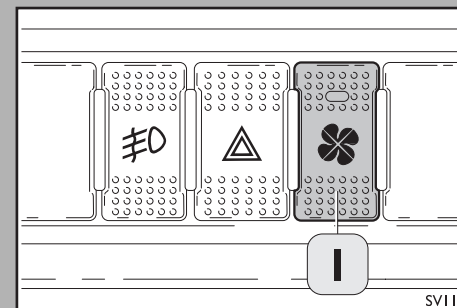

Standard on Daily 4x4

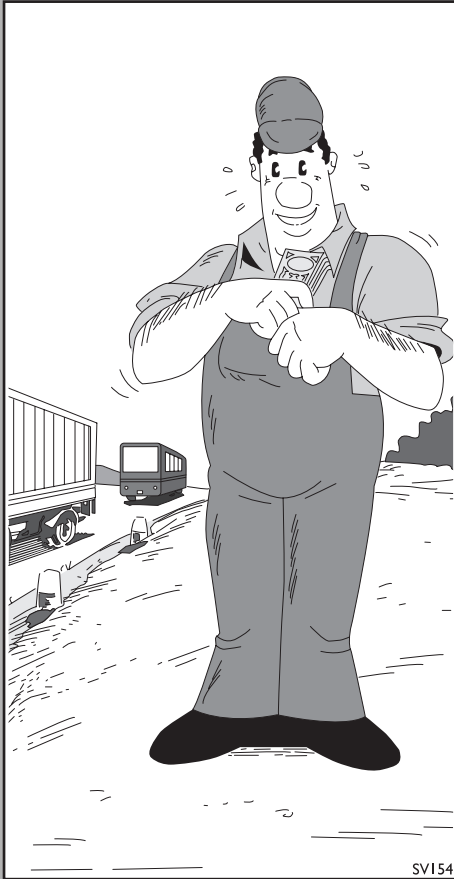

Economical, environmentally-friendly driving

- Never demand maximum vehicle performance with the engine cold.
- Do not rev the engine needlessly during stops.
- When possible, do not drive with the side windows down; it is preferable to use the ventilation and air conditioning system rationally to obtain the required ambient conditions inside the vehicle.
- When traffic and road conditions allow, use a high gear.
- In slow urban traffic or when driving in a line at low speed, it is advisable to limit the use of devices with high energy absorption (interior ventilation at max. speed).
- "Reving" the engine when changing gear and before stopping is unnecessary and must be avoided.



The conditions of use and driving behaviour have a direct effect on fuel consumption and environmental impact. By following a few simple rules, without forgoing "bright" driving, the driver can avoid damage to the environment, and at the same time reduce fuel consumption.

STARTING AND DRIVING

- Carry out with maximum care and regularity the maintenance and tuning operations prescribed by IVECO; This is an essential condition to guarantee better service life of the mechanical parts and substantial fuel savings.

Safeguarding the devices that reduce emissions

Correct working of the antipollution devices not only ensures respect for the environment but also positively affects vehicle performance. Keeping these devices in a good condition is therefore the first rule for economical and ecological driving.

Particulate filter (if fitted)

- The DPF (Diesel Particulate Filter) is a filter for the fine particles emitted by combustion. It is not subject to maintenance since the engine control unit periodically "commands" the particle combustion process to clean it (reconditioning) by emitting more diesel. During the process of particle combustion in the filter, the gas reaches a temperature of 650° C, overheating the filter. Even during normal operation there is brief "natural" reconditioning that involves overheating the exhaust line. **Therefore, it is recommended not to park the vehicle on easily flammable materials (dry grass and leaves, paper, flammable liquids, etc.) Follow the plan of scheduled maintenance scrupulously:** regular maintenance is the best guarantee for safe operation and for keeping operating costs as low as possible. Such operations are compulsory during the warranty period. Failure to carry them out will invalidate the warranty.

STARTING AND DRIVING

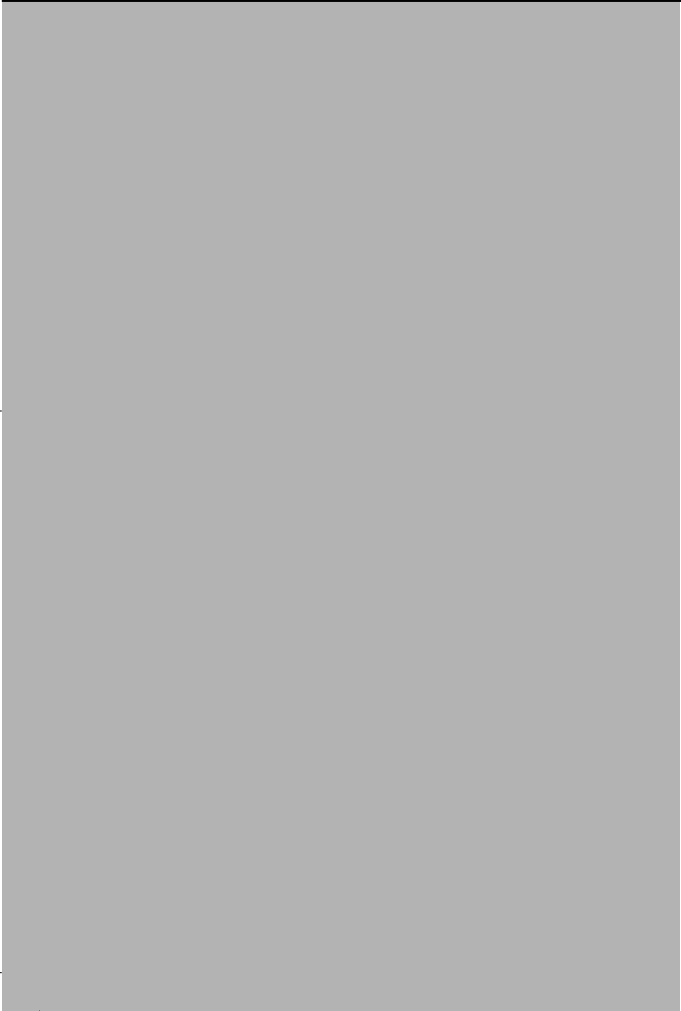

ON BOARD EQUIPMENT

> **CAUTION!**

Risk of accident: Do not leave objects in the cab that could shift and hinder the controls or strike the occupants in case of a collision.

On board equipment

Every vehicle is supplied with spanners and tools so that the customer can carry out normal use and maintenance operations.

ON BOARD EQUIPMENT

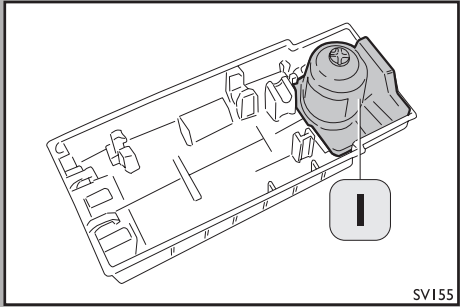

The tools and accessories in the container under the driver's seat are to be placed after each use by following this procedure only: (some of the accessories may not be provided on your vehicle)

I - Jack

ON BOARD EQUIPMENT

- 2 - Rod for jack
- 3 - Rod for extension
- 4 - Two chocks
- 5 - Wrench for stud pins
- 6 - Tool bag
- 7 - Hazard warning triangle

The vehicle can be provided with 2 types of blades for windscreen cleaning: one for removing dirt or rain and one for removing ice or snow.

These blades have a telescopic arm allowing the windscreen to be easily reached from the ground.

If your vehicle is fitted with a first aid box/emergency lamp, these accessories are located in the box underneath the passenger seat.

Note:

The content of the tool bag may vary according to the version.

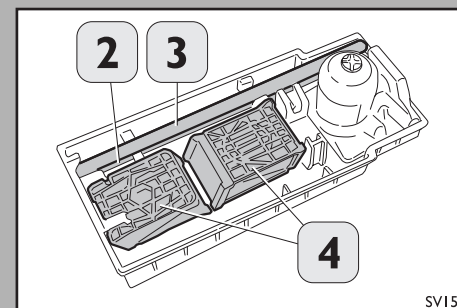

SV156

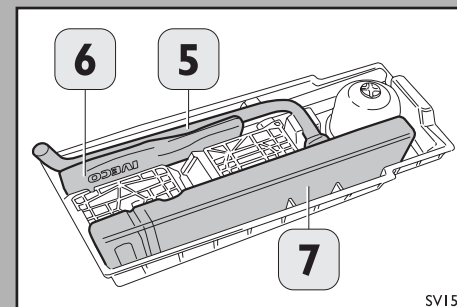

SV157

ON BOARD EQUIPMENT

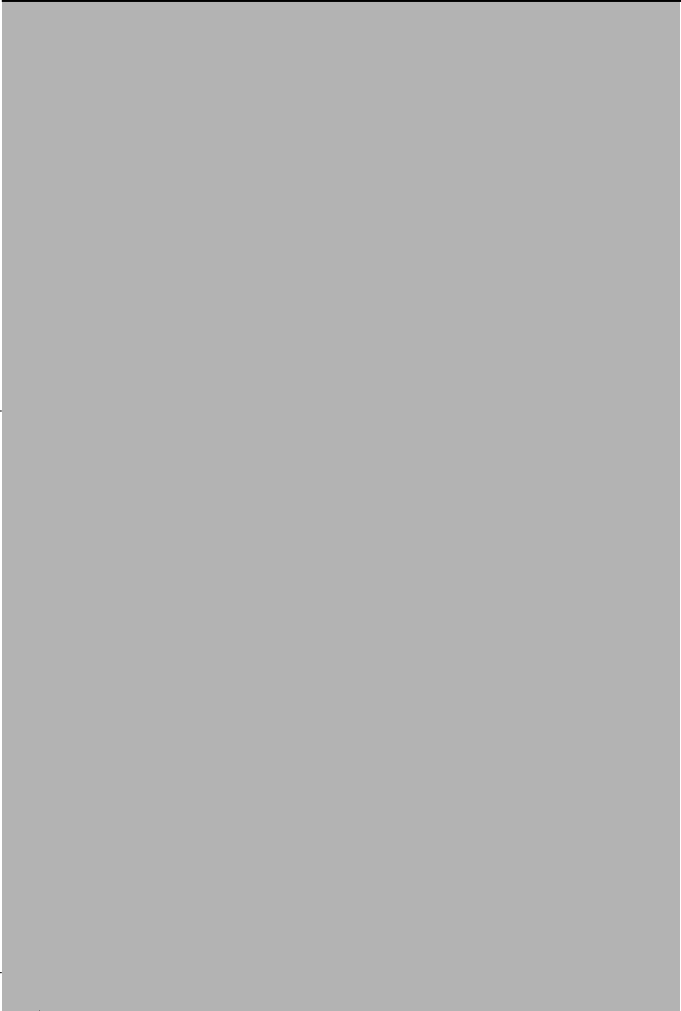

Quick intervention

This chapter provides information for resolving the minor problems that can occur when using your vehicle:

Spare wheel	198
Changing wheels	199
Replacing lamps	200
ECU's	201
Battery	208
Towing the vehicle	213
Quick troubleshooting guide	214

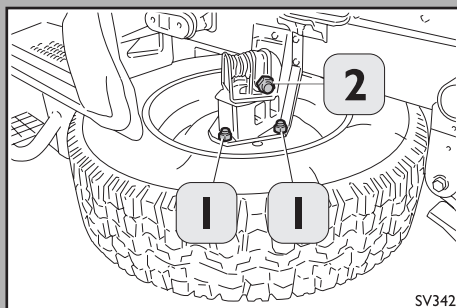
QUICK INTERVENTION**Spare wheel**

To remove the spare wheel, located on the left side of the vehicle:

- Undo the fixing nuts (1).
- Insert the special wrench in the seat (2).
- Turn the wrench clockwise until the wheel is arranged on the ground.

**CAUTION!**

When refitting the new wheel, fully tighten the device 3 on the spare wheel holder. For reasons of safety periodically check that the spare wheel is correctly fastened.



> **Important!**

For correct tightening only use the tools supplied with the vehicle.

Important: When the vehicle is new, and every time after the wheel has been removed, the nuts must be retightened after the first 50 km and the next 100 km.

Remember: For your safety, only use original wheels and fixing elements.

Changing wheels

Carefully clean wheel studs, nuts and supporting surfaces before fitting the wheel.

NOTE: The above suggestion may also help in future nut loosening. Tighten the fixing nuts in the order indicated in the figure, carrying out the following steps using tool provided:

- Tighten the nuts enough so that the wheel is correctly coupled to the fixing element.
- Tighten according to the sequence indicated.
- Lower the wheel to the ground and tighten down the nuts applying your body weight (approx. 70 kg) on the end of the lever. (This obtains approximately the prescribed torque value).
- Check the tyre pressure.

Wheel nut tightening torque:

Front axle 305 ÷ 375 Nm (31.09 kgm ÷ 38.23 kgm)

Rear axle 305 ÷ 375 Nm (31.09 kgm ÷ 38.23 kgm)

QUICK INTERVENTION

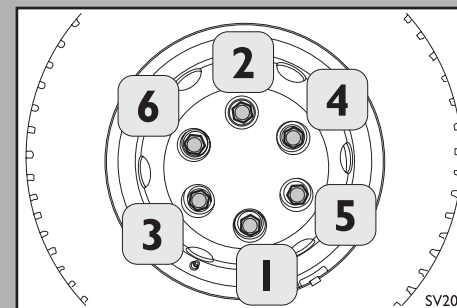

QUICK INTERVENTION

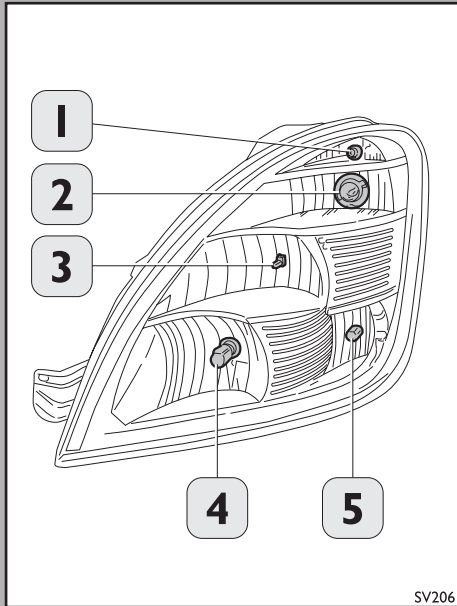

Replacing lamps (to open the engine compartment, see page. 218)

Front light cluster

The light cluster contains the lamps of the side lights, indicators, low beam, high beam and fog lights. The headlight lamps are arranged as follows:

1. Parking light.
2. Direction indicator.
3. High beam.
4. Low beam.
5. Fog light.

To access the lamps, firstly remove the rear rubber cover: after replacing them, refit the covers, ensuring their correct position.

Please note;
Lights 4 and 5 not used in Daily 4x4
These are located in the front bumper



- Do not touch the halogen lamps with fingers; protect them with tissue paper. In case of accidental contact, clean them with alcohol and leave to dry. For the lamps to work properly, it is advisable to have them replaced by the *Service Network*.
- Respect the powers indicated by IVECO, or there will be fault diagnosis signals on the instrument panel and possible switching off of the lights system to protect against overloads managed by the control unit.

QUICK INTERVENTION

View from inside after removing the covers

1. Parking light.
2. Direction indicator.
3. High beam.
4. Low beam.
5. Fog light.

Parking lights and indicators**To replace the parking lamp, proceed as follows:**

- Remove the protection cover; and remove the lamp holder (6) pulling it towards you; remove the lamp and replace it; refit the lamp holder, making sure it clicks in place; check the correct positioning of the lamp, controlling the light from the outside; refit the protection cover, pressing all around the edge.

To replace the indicator lamp, proceed as follows:

- Remove the protection cover, and turn the lamp holder (7) anticlockwise; remove the lamp by pressing lightly and turning it anticlockwise; replace the lamp, refit the lamp holder turning it clockwise and making sure it is properly in. refit the protection cover, pressing all around the edge.

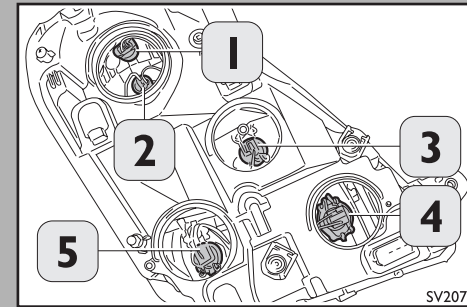

SV207

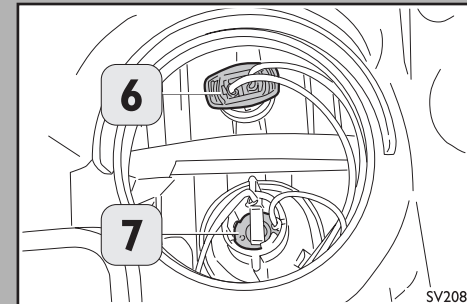

SV208

QUICK INTERVENTION

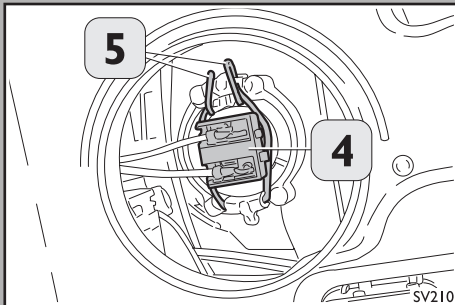
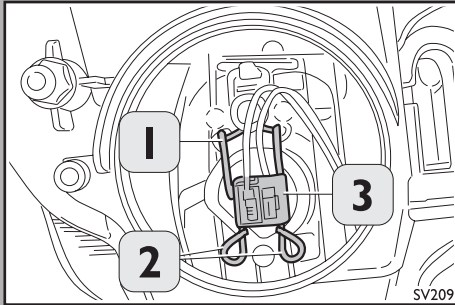

High beams

To replace a lamp, proceed as follows:

- remove the protection cover; unhook the lamp clip 1, lift its two tabs (2) towards you and widen them at the sides of the lamp, grip the connector (3) with two fingers and pull it towards you; after removing it, disconnect the lamp and replace it with a new one without touching the glass with fingers, check that connector (3) is properly fitted on its terminal, refit the connector and the lamp, making the profile and the two bumps match in the seat obtained on the reflector; hook the lamp holder clip back on by lifting and pulling the two tabs towards you, positioning them both on the cup of the lamp, check that the lamp is positioned correctly from outside the light; refit the protection cover, pressing all around the edge.

Low beams

To replace a lamp, proceed as follows:

- remove the protection cover; disconnect the electrical connector (4) from the lamp; unhook the lamp holder clip (5) by pressing on the eyelets and widening them, turn the clip downwards, remove the lamp, replace it with a new one without touching the glass with fingers, making the shape of the metal part match the grooved seat obtained on the reflector; rehook the lamp holder clip, refit the electrical connector (4), check that the lamp is positioned correctly from outside the light; refit the protection cover by pressing all around the edge.

QUICK INTERVENTION

FOG LAMPS

To replace a lamp, act as follows:

- remove the protection cover; unhook the lamp clip (1), lift its two tabs (2) towards you and widen them at the sides of the lamp, grip the connector (3) with two fingers and pull it towards you; after removing it, disconnect the lamp and replace it with a new one without touching the glass with fingers, check that connector (3) is properly fitted on its terminal, refit the connector and the lamp, making the profile and the two bumps match in the seat obtained on the reflector; rehook the lamp holder clip, lifting and pulling the two tabs towards you, positioning both on the cup of the lamp, check that the lamp is positioned correctly from outside the light; refit the protection cover by pressing all around the edge.

Side direction indicators

- Remove the wide-angle reflector with a tug (the mirror looks as in the photo), then remove the safety screw (1).

Using a screwdriver, slightly lower the upper clip of the indicator 2. The indicator will unhook from its seat and be easily removed.

If necessary, do it on the lower clip too.

After changing the lamp, fit the indicator back in its seat with the two rear references, then click the indicator body back in place, put the screw 1 back in its seat and press the wide-angle reflector back on.

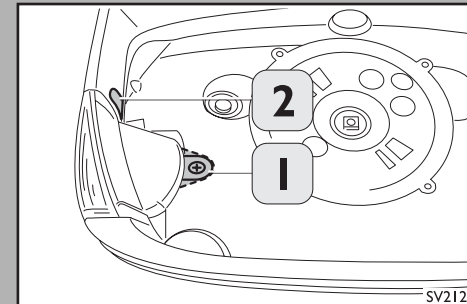
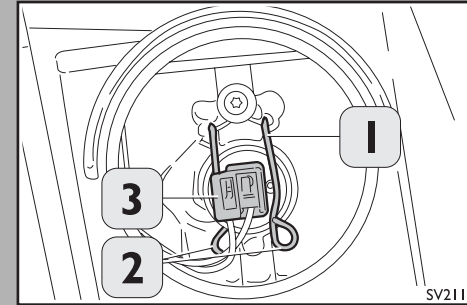

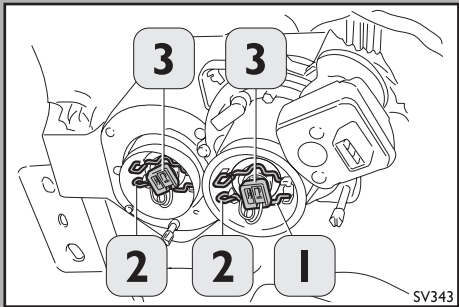
QUICK INTERVENTION**Supplementary front lights: low beam and fog lights**

To replace the lamps, proceed as follows:

remove the protection cover; unhook the lamp clip (1), lift its two tabs (2) towards you and widen them at the sides of the lamp, grip the connector (3) with two fingers and pull it towards you; after removing it, disconnect the lamp and replace it with a new one without touching the glass with fingers, check that connector (3) is properly fitted on its terminal. Refit the connector and the lamp, making the profile and the two bumps match in the seat obtained on the reflector; rehook the lamp holder clip, lifting and pulling the two tabs towards you, positioning both on the cup of the lamp, check that the lamp is positioned correctly from outside the light; refit the protection cover by pressing all around the edge.

QUICK INTERVENTION

Rear lights

To replace a lamp in the rear light cluster, proceed as follows:

- unscrew the fixing screws (1) of the transparent cover.
 - Remove the transparent cover.
2. Parking light and brake light.
 3. Direction indicator.
 4. Reversing light.
 5. REAR FOG LAMP.
 6. Reflector.

- Refit the transparent cover.
- Retighten the transparent cover fixing screws (1).

To replace the lamps of the number plate light, proceed as follows:

- Unscrew the fixing screws (1).
- Remove the support.
- Replace the light lamp (7).
- Fit the support back on.
- Retighten the fixing screws (1).

All lamps can be removed by means of a standard bayonet fitting.

Note: The rear light cluster and the number plate lights of the vans are described and illustrated in the specific chapter.

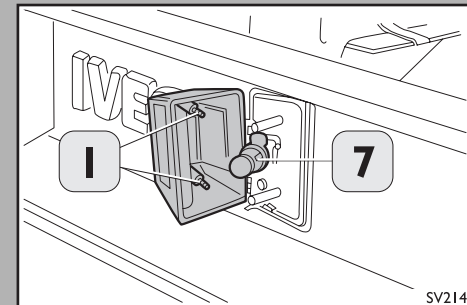
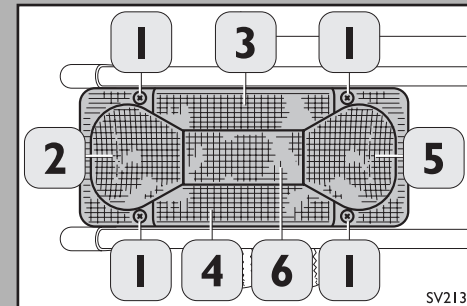

QUICK INTERVENTION

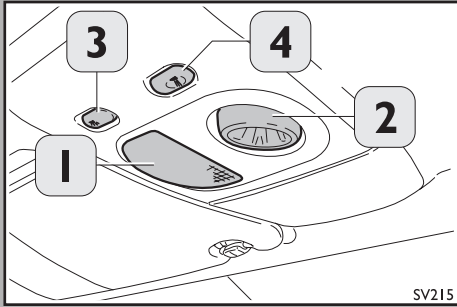
**Interior lights**

To replace the lamps, proceed as follows:

- Work on the ceiling lighting fixture that is fixed by being pressed on.
The lamps are arranged as follows:
 1. Two cylindrical lamps. **Actually only one. 42 mm long.**
 2. Tube lamp (adjustable light beam). **W5W pigtail type.**
- Refit the courtesy light.
 3. Fixed light switch.
 4. Adjustable light switch.

Precautions to be taken with ECU's installed

To avoid incorrect operations which could permanently damage or negatively affect the operation of the electronic control units fitted on the vehicle, comply with the following:

- In case of any work on the chassis requiring arc welding: disconnect the batter positive terminal and connect it to the chassis ground; detach the connector from the control units; for welding near the control unit, remove it from the chassis; carry out welding with direct current; ground the welder as close as possible to the place of welding; do not arrange the battery cables parallel to the vehicle's electrical cables.
- Do not detach and/or connect the connectors from the control units with the engine running or with powered control units.
- After any maintenance requiring battery disconnection, make sure the terminals are properly connected to the poles when reconnecting it.
- Do not disconnect the battery with the engine running.
- Do not use a battery charger to start the engine.
- Disconnect the battery from the on-board system in case of charging.
- Remove the ECU's whenever particular operations require temperatures above 80°C.

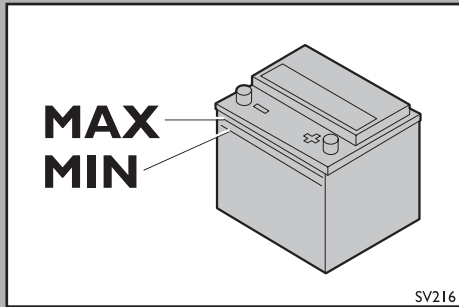
QUICK INTERVENTION**Mandatory operating precautions**

Before performing any repair operation on electrical system ECUs, and specifically before replacing engine start-up contactor if required, strictly comply with following prescriptions to prevent short circuiting:

- Before removing the remote control switch from the control unit, disconnect the main current switch or detach the battery connection terminals.
- Fit a new remote control switch if the plastic protection is accidentally detached or the remote control switch was opened for any reason when being removed from the control unit.
- Do not expose at over 100°C (sparks, welding, etc.) in the immediate vicinity of pretensioners and airbags.

Battery

The battery provided is a low maintenance type and, therefore, under normal conditions of use, does not need to be topped up with electrolyte. A routine inspection is however recommended to check if electrolyte level is still between MIN and MAX levels on the battery.

QUICK INTERVENTION**Warnings for preventing accidents when handling batteries**

1. Do not smoke or handle fires and naked flames. Do not create sparks. Prevent the creation of sparks when connecting devices or measuring instruments directly to the batteries. Before disconnecting batteries, disconnect fed devices (tachograph, interior lights, etc.) by removing the corresponding fuse in the ECU. Firstly disconnect the ground. Avoid short circuits caused by inverted connections or handling with wrenches. Do not remove the caps from the terminals if not necessary.

During connection, fit the ground cable last.

2. Wear protection glasses or masks!
3. Keep acids and batteries out of the reach of children!
4. The battery contains acid. Wear protective gloves and clothing. Do not tilt or overturn battery: acid could spill out of the breather holes.
5. Comply with the indications given in the instructions for use and in the documentation supplied by the battery manufacturer.
6. Risk of explosion! Pay special attention after charging the battery or after long trips. During recharge, explosive gas is produced (mixture of hydrogen and oxygen). Ensure proper ventilation.

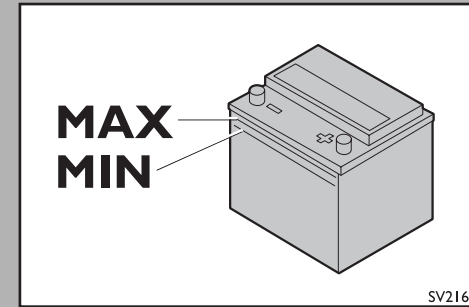

QUICK INTERVENTION

**Warnings:**

- The batteries contain substances that are very hazardous for the environment. To replace batteries, it is advisable to contact the *Service Network* which is equipped for battery disposal in respect for the environment and in compliance with the regulations.
- Incorrect fitting of electrical accessories can cause serious damage to the vehicle. If, after purchasing the vehicle, accessories are to be installed, contact the Iveco *Service Network* which will suggest the most suitable devices and advise on the necessity of using a battery of greater capacity.
- The liquid contained in the batteries is poisonous and corrosive. Avoid contact with the skin and the eyes. Operations must be carried out in a ventilated place and away from naked flames or possible sources of sparks (cigarettes, etc.): risk of fire and explosion.
- If battery is left at 50% of total capacity, damages may result due to sulphating, impaired start performance and greater exposure to freezing (which may already occur at -10°C).
- The starting procedure described above must be carried out by expert personnel, since incorrect actions can cause electrical discharges of substantial intensity.
- To avoid damaging the vehicle's electrical system, carefully follow the cable manufacturer's instructions. The cables must have a sufficient section and be long enough so that the two vehicles do not touch each other.
- Never use a fast battery charger for emergency starting: it could damage the electronic systems and in particular the ECU's that manage the ignition and feed functions.
- Connection and disconnection of the battery terminals generate voltages that can cause problems with the vehicle's electronic systems and control units. These operations must be carried out by expert personnel.

QUICK INTERVENTION**Useful advice**

To avoid rapidly flattening the battery and to preserve it during operation, comply with the following:

- The terminals must always be properly tightened.
- Do not keep loads (car radio, lights, etc.) switched on for long periods with the engine off.
- When the engine is turned off and the vehicle is left after correctly parking it, make sure no interior or exterior lights are left on.
- Before any operation on the electrical systems, disconnect the negative pole of the battery.

Charging

Warning: The description of the battery recharging procedure is given only for information purposes. For this operation, contact the *Service Network*.

Slow charging at low amperage for approx. 24 hours is advisable. Longer recharging or more aggressive charging could damage the battery.

Follow the procedure below for recharging:

- If the vehicle is equipped with an alarm system, deactivate the system.
- Disconnect the electrical system terminals from the battery poles.
- Connect the charger cables to the battery poles.
- Switch on the battery charger.
- After recharging, switch off the charger before disconnecting it from the battery.
- Reconnect the terminals to the battery poles, respecting the polarities.

QUICK INTERVENTION**Starting with auxiliary battery**

If the battery is flat, the engine can be started using an auxiliary battery having electrical characteristics equivalent to those of the original battery.

Starting with an auxiliary battery does not cause damage to the immobiliser system and must be done according to the following procedure:

- Disconnect all electrical devices that are not strictly necessary.
- Connect the positive terminals of the two batteries (+ sign next to terminal) using an ancillary cable.
- Connect a second cable from the negative terminal of the charged battery to the ground of the vehicle with the flat battery.
- Start the engine.
- When the engine has started, keep the cables connected for at least 10 minutes.
- Remove the cables in reverse order to that of the connection procedure.
- If the motor does not start after several attempts, do not persist; contact the *Service Network*.



> **Risk of accident:** with the engine stopped there is no assisted power for brakes and steering. This requires a considerably greater effort when braking and steering. .

Tow the vehicle (with an approved tow bar: comply with the current regulations on towing)

Use the screwable hook included in the vehicle's outfit and insert it at the point located under the cover as directed.

When having to tow the vehicle for long stretches, disconnect the transmission shaft from the axle flange.

If the engine fails to start (e.g. battery flat or very low temperatures) use an auxiliary battery with equivalent electrical characteristics (refer to the section on batteries).

Push starting is not recommended.

However, if push or pull starting is necessary; proceed as follows:

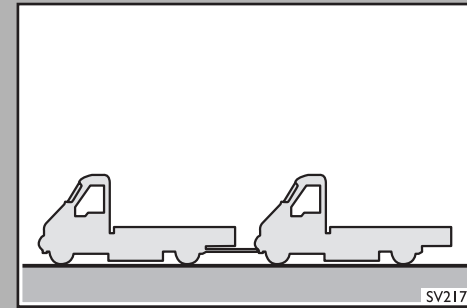

- engage a high gear (e.g. 3rd, 4th),
- moderate the speed (even when downhill),
- release the clutch pedal gradually.

QUICK INTERVENTION





QUICK INTERVENTION

Quick troubleshooting guide

WARNING LIGHT ON	TROUBLE	REMEDY
	Water in fuel filter.	Drain the water. If the indicator remains on, change the filter.
	Low engine oil pressure.	With the engine cold, check the level and top up if necessary. If the fault persists, contact the Service Network.
	ABS fault.	Contact the <i>Service Network</i> as soon as possible.

QUICK INTERVENTION

WARNING LIGHT ON	TROUBLE	REMEDY
	Brake inefficiency worn brake pads, EBD failure.	Check the brake fluid level. If the level is low, seek assistance from the <i>Service Network</i> which should carry out a general check on the system and/or replace the brake pads. Check the EBD system.
	Insufficient battery charge	Seek assistance from the <i>Service Network</i> .
	Engine coolant level low	Check the level and top up if necessary (this operation should be carried out with the engine cold). If the fault persists, contact the <i>Service Network</i> .

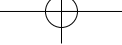

QUICK INTERVENTION

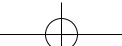
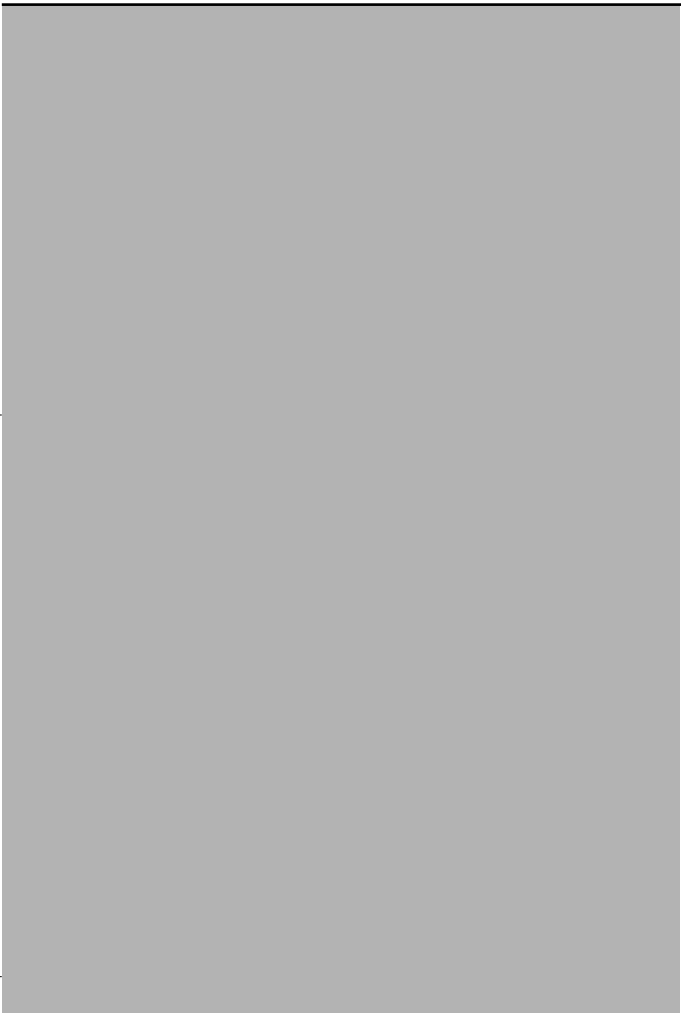

CHECKS TO BE CARRIED BY THE USER**Checks to be carried by the user**

Becoming familiar with some simple control and verification procedures is very important. Carry out a preventive check-up of all the services required for correct replacement of tyres (positioning the jack for lifting, use of spanners, etc...). Do not consider these operations as mere routine; the perfect efficiency of your vehicle depends to a large extent on them.

Good preventive maintenance on your part is all-important for supporting the scheduled maintenance provided for by the Service Network, saving you time and problems.

CAUTION!

In the event of abnormal smoke emission at the exhaust or unusual engine noises, go to an IVECO service location.

Engine compartment opening**Before each trip****Every week****Vehicle care**

218

221

226

230

CHECKS TO BE CARRIED BY THE USER

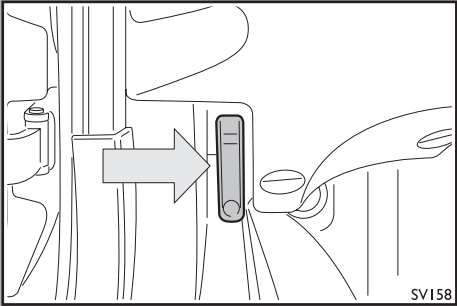

Engine compartment opening

Lift the bonnet after unlocking it from inside by pulling the control as illustrated.

Free the hook (1) by pressing it and lift the bonnet.

Insert the rod (2) in the special slot, making sure it is properly inserted.



- > **Risk of injury:** When the engine bonnet is open there is risk of burns due to very hot engine parts. When the engine is running there is risk of injury due to rotating engine parts. Pay attention to scarves or loose clothing; they could get caught in the moving parts.

CHECKS TO BE CARRIED BY THE USER

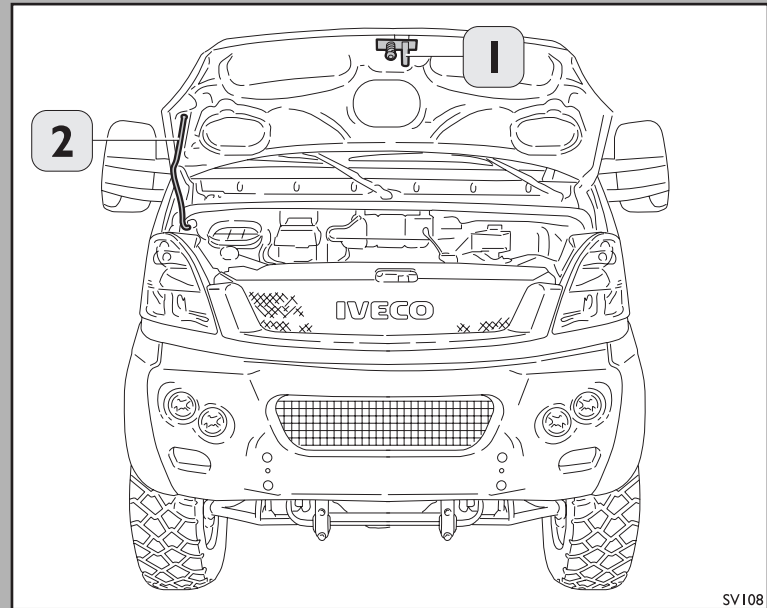

SV108

CHECKS TO BE CARRIED BY THE USER

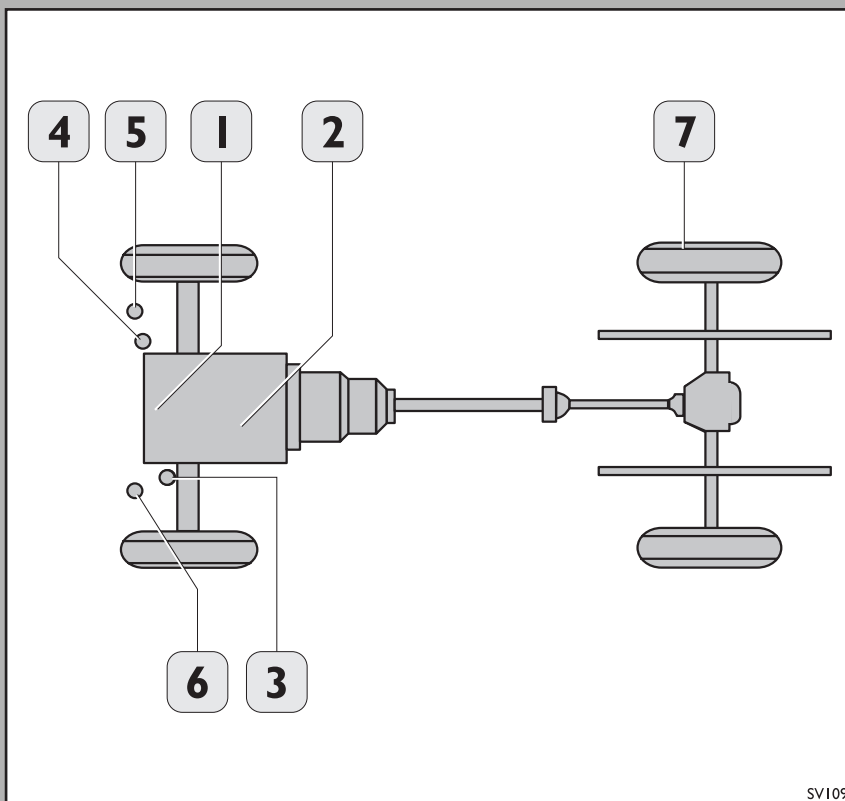

SV109

• Before each trip

1. Engine oil.
2. Engine coolant.
3. Brake fluid.
4. Windscreen wiper liquid.

• Every week

5. Power steering.
6. Fuel filter.
7. Tyres.



- > • **Risk of accident:** after topping up, close the filler 2 properly to prevent dangerous oil leaks while driving.
- Do not exceed the maximum level when topping-up oil.

Before each trip

1. Check the engine oil level with the dipstick (1).
Top up if necessary through the filler (2).

Notes:

- Wait at least 15 minutes after the engine stops before checking the level.
- On engines equipped with a particulate trap the oil must be changed at authorized garages only.

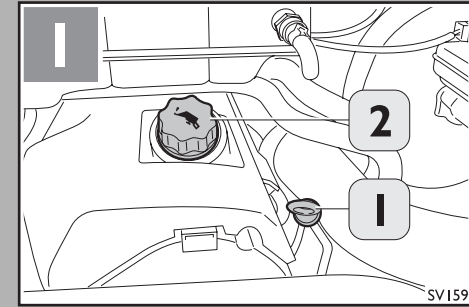

SV159

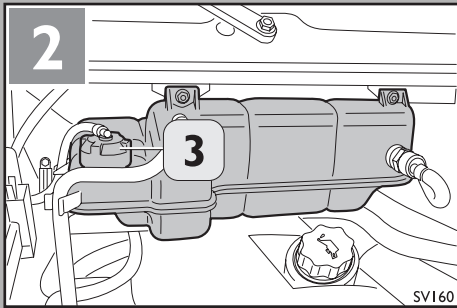
CHECKS TO BE CARRIED BY THE USER

2. Check the coolant level.

It should never go below the MIN level. Top up if necessary through the filler (3).

**CAUTION!**

Carry out the check only with the engine off and sufficiently cold; otherwise opening the cap can result in very hot liquid spurting out.



> **CAUTION!**

The brake fluid is toxic and corrosive: in case of accidental contact, immediately wash with water and neutral soap.

3. Check the brake fluid level. If the level is low, contact the Service Network.

CHECKS TO BE CARRIED BY THE USER

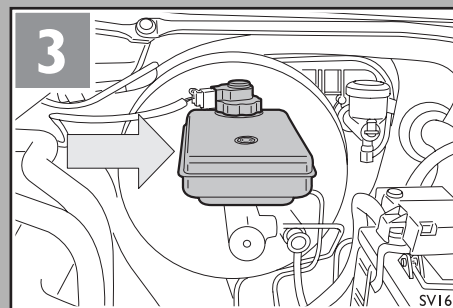

CHECKS TO BE CARRIED BY THE USER

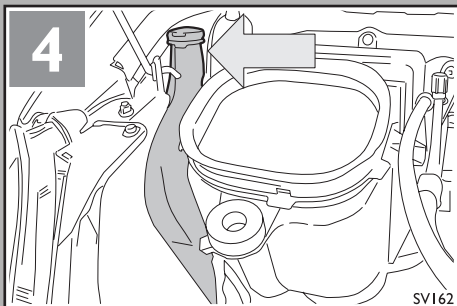

4. Check the fluid level in the screen washer reservoir: should a top-up be necessary, we recommend a mixture of water and **Tutela Professional SC 35** fluid.

Also make sure the pipes are not obstructed; if necessary, clean the spray nozzles with a pin.



CAUTION!

Some commercial wind-screen washing additives are flammable: pay attention to contact with hot engine parts.

CHECKS TO BE CARRIED BY THE USER

Then, check:

- The condition of the battery terminal connection cables.
- Operation of the service and parking brakes.
- Operation of the lights, warning lights, horn and windscreen wipers.

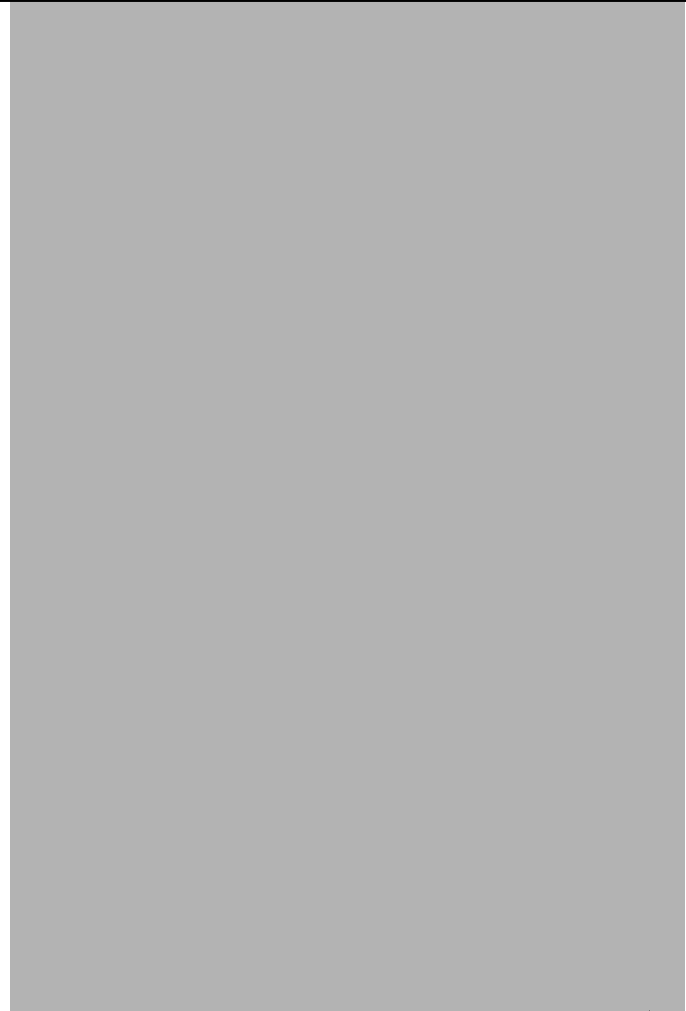

CHECKS TO BE CARRIED BY THE USER

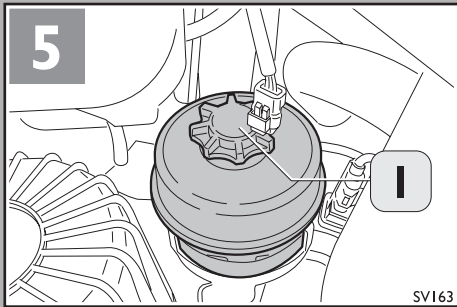

Every week

5. Remove power steering reservoir cap (I) and check the fluid level.
If necessary, remove the cover and top-up the level.

CHECKS TO BE CARRIED BY THE USER

6. If the indicator on the instrument panel lights up (if provided for by the version) drain the condensation water by turning the cock on the bottom end of the fuel filter. If the indicator remains on, change the filter.

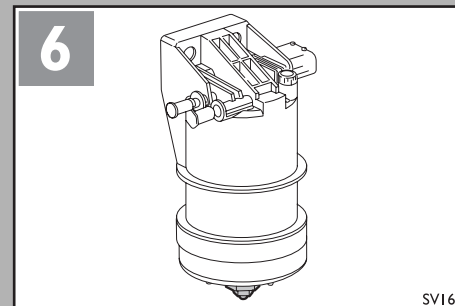

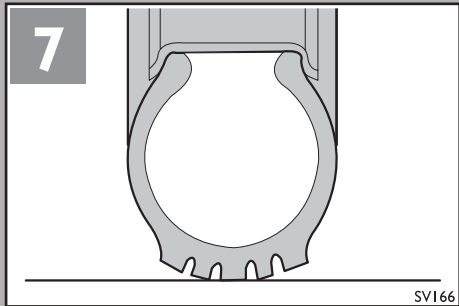
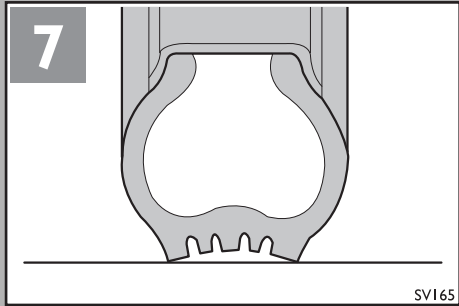
CHECKS TO BE CARRIED BY THE USER

7. Check the tyre wear and pressure (including spare wheel). If the pressure is low, tyres tend to wear on the outer part of the tread when driving. If the pressure is too high, tyres tend to wear in the middle part of the tread when driving. In case of abnormal wear on the front tyres (on the inner or outer part of the tread) have the front wheel alignment checked. Never exceed the maximum weight per axle (with vehicle fully loaded). Replace the pair of tyres on the axle when continuous bands extending over the entire width of the tyre are visible due to worn tread blocks. The tyres also have tread wear indicators: change the tyres when the tread wear reaches these indicators.

CHECKS TO BE CARRIED BY THE USER**> CAUTION!**

- On vehicles fitted with a hydraulically controlled clutch, the reservoir cover must not be removed: the assembly is maintenance free.
- In some conditions the particulate trap can generate high exhaust gas temperatures. Therefore do not park the vehicle on flammable material such as grass, dry leaves, pine needles, etc., fire hazard.

Then, check:

- The exhaust gas system.

The devices that can be used to reduce the emissions of diesel engines are the particulate trap and the exhaust gas recirculation system (E.G.R.).

Important;
Please take note of the cautionary advice regarding the clutch system

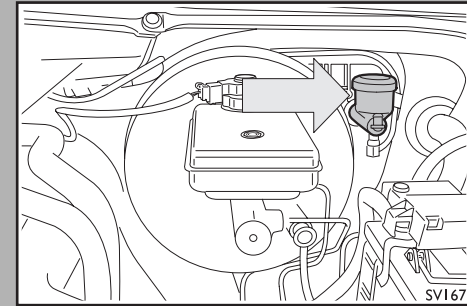

CHECKS TO BE CARRIED BY THE USER



SV119

Vehicle care**Coachwork maintenance**

Periodically wash the vehicle with neutral products and water.

The frequency of washing depends on the following factors:

- Areas with high air pollution.
- Travelling on roads treated with ice melting salt.
- Parking under trees that produce resinous substances.
- To prevent deep scratches and dulling of the paintwork, do not use brushes with hard fibres or dirty cloths.
- Dry thoroughly to completely remove any water pockets.
- Do not wash the vehicle after prolonged exposure to the sun, otherwise the paintwork may become dull.
- Do not immediately place the vehicle in a closed place, but leave it in the open to favour evaporation of the water.

**Warning!**

Detergents pollute water.
Therefore, wash the vehicle in an area equipped for collection and purification of the liquids used for washing.

CHECKS TO BE CARRIED BY THE USER**Cleaning plastic parts**

The external plastic parts must be cleaned with the same procedure used for washing the vehicle.

If there are still traces of dirt, it is advisable to use specific products, carefully following the manufacturer's instructions. The use of such products is also recommended for cleaning the plastic coverings inside (dashboard, doors, etc.). Do not use products for cleaning the paints or products containing aromatic solvents, methanol or hydrocarbons.

Window cleaning

Use specific products for cleaning; use clean cloths so as not to scratch the glass or alter its transparency.

Cleaning the interior and fabric parts

Dust on the seats and the fabric parts can be removed with the aid of a soft brush. More intensive cleaning can be carried out with dry foams and solvents in general. Use these substances with the necessary care, as they are flammable and give off vapours. Therefore ensure adequate ventilation of the cab until it they dry. Do not use chlorine solvents (trichloroethylene, hyper chlorine solutions, etc.). Do not use jets of water for interior cleaning as they can damage the electrical components installed in the underdashboard and/or under-seat compartments; take the necessary precautions to safeguard their correct operation.

Washing the engine

It is advisable to see an authorised workshop for this operation; in any case, washing must be done very carefully and with the engine cold.

This is to prevent damage to the electrical components of the system.



CHECKS TO BE CARRIED BY THE USER



Windscreen wipers, windscreen washers and headlamp washers

Periodically check the blades; if worn and dirty, visibility can be significantly reduced. Regularly clean the windows by removing grease and grime; this will considerably increase the life of the blades.

Before operating the windscreen wipers, remove any snow or ice present: in temperatures below zero, before operating the windscreen wipers make sure ice has not stuck the rubber part to the glass: if necessary, use a de-icing product. Do not operate the windscreen wipers on dry glass; if the rubber wipers are warped or have worn sections, replace the blades.

Make certain that both the spray nozzles of the windscreen and those of the headlamp washers (if provided) eject an adequate jet of liquid and are correctly aligned. If the spray nozzles do not work, make sure the feed circuits are not obstructed; if necessary, clear the outlet holes with a pin.

SCHEDULED MAINTENANCE

Scheduled maintenance

Long life and perfect operation with periodical maintenance:

Scheduled maintenance philosophy	234
Maintenance services schedule	235
Maintenance stops by kilometres	237
Maintenance stops by hours	238
Table of maintenance operations	239
Overall maintenance and lubrication plan	244

SCHEDULED MAINTENANCE

Scheduled maintenance philosophy

The following pages give the checking, inspection and adjustment operations necessary for the various parts of the vehicle at the scheduled times to ensure the perfect efficiency of your vehicle. Regular maintenance is the best guarantee for safe operation and keeping running costs at optimum levels.

Contact the service network to carry out the specified operations.

These operations are to be carried out at the given mileages.

Such operations are compulsory during the warranty period. Failure to carry them out will invalidate the warranty.

The operations must be carried out exclusively by the Service Network, which must confirm them by adding the date, stamp and signature in the special boxes provided in the overall maintenance plan.

User recommendations

Engine lubrication intervals are in relation to a percentage of sulphur in diesel fuel lower than 0.5% (according to standard EN 590).

SCHEDULED MAINTENANCE

Maintenance services schedule

For the relative kilometre distances observe the following.

ENGINE OIL	TYPE OF USE	STANDARD SERVICES				EXTRA-PLAN OPERATIONS	TIMED OPERATIONS			
		M1	M2	M3	M4	EPI	T1	T2	T3	T4
Urania Daily ACEA C2(1)	Heavy usage (mainly off road)	Every 20,000 km or every 400 hours	Every 40,000 km or every 800 hours	Every 60,000 km or every 1,200 hours	Every 120,000 km or every 2.400 hours	Every 200,000 km or every 4,000 hours	Every year at the start of spring	Every year at the start of winter	Every 2 years	Every 3 years
	Road use	Every 40,000 km or every 800 hours	Every 80,000 km or every 1,600 hours	Every 120,000 km or every 2,400 hours	Every 240,000 km or every 4,800 hours	Every 400,000 km or every 8,000 hours				

(1) IVECO recommends using URANIA Daily ACEA C2 for better fuel economy. New vehicles are already equipped by IVECO with this type of lubricant.

Notes:

- The fuel filter must be changed in any case when the clogging warning light on the instrument panel comes on.
- If fuel with a percentage of sulphur higher than 0.5% is used, the interval for the replacement of the engine oil must be halved.
- The engine oil and filter must be changed at least once a year regardless of the km covered.
- The transmission assembly, drive axle and rear axle oil must be changed in any case every 2 years.
- The transmission oil must be changed in any case every 3 years.

Important:

- Refuelling Only use diesel fuel normally available on the market (Standard EN590). Fuel additives are not recommended. The use of additives can limit the warranty services offered for the vehicle. Refuelling from drums or cans may pollute the diesel fuel and affect the fuel supply system and so, when filling in this way, possible impurities must be eliminated by filtration or sedimentation.
- Low temperature diesel fuel At low temperatures the fluidity of the diesel fuel may become insufficient due to separation of the paraffin, with clogging of the filters. Standard EN 590 specifies different classes of diesel fuel for use at low ambient temperatures. It is entirely up to the oil companies to comply with the standards according to the climatic conditions (seasons and geographical location of the countries).

SCHEDULED MAINTENANCE

Maintenance stops by kilometres

Heavy Duty Use

KM	SERVICE	KM	SERVICE	KM	SERVICE
20000	M1	100000	M1	180000	M3
40000	M2	120000	M4	200000	M2
60000	M3	140000	M1	220000	M1
80000	M2	160000	M2	240000	M4

Road use

KM	SERVICE	KM	SERVICE	KM	SERVICE
40000	M1	200000	M1	360000	M3
80000	M2	240000	M4	400000	M2
120000	M3	280000	M1	440000	M1
160000	M2	320000	M2	480000	M4

SCHEDULED MAINTENANCE

Maintenance stops by hours

Heavy Duty Use

HOURS	SERVICE	HOURS	SERVICE	HOURS	SERVICE
400	M1	2000	M1	3600	M3
800	M2	2400	M4	4000	M2
1200	M3	2800	M1	4400	M1
1600	M2	3200	M2	4800	M4

Road use

HOURS	SERVICE	HOURS	SERVICE	HOURS	SERVICE
800	M1	4000	M1	7200	M3
1600	M2	4800	M4	8000	M2
2400	M3	5600	M1	8800	M1
3200	M2	6400	M2	9600	M4

SCHEDULED MAINTENANCE

TABLE OF MAINTENANCE OPERATIONS				
	M1	M2	M3	M4
Lubrication, oil and filter change, fluids check				
Change engine oil	●	●	●	●
Change the engine oil filter	●	●	●	●
Change fuel filter cartridge (1)	●	●	●	●
Change mechanical transmission oil			●	●
Check electrohydraulic unit oil level (A.P.U.) com. differential lock	●	●	●	●
Check brake hydraulic system fluid level	●	●	●	●
General chassis greasing	●	●	●	●
Change transmission assembly oil		●		●
Change drive axle oil		●		●
Change rear axle oil		●		●
Engine compartment checks				
Check various belts	●	●		
Change alternator and coolant pump drive belt/s			●	●
Change air conditioner compressor belt			●	●
Replacement of movable alternator belt tensioner				●
Change glow plugs				●

(1) If the clogging indicator on the instrument panel lights up, the filter must be changed in any case before the normal change interval.

SCHEDULED MAINTENANCE

TABLE OF MAINTENANCE OPERATIONS				
	M1	M2	M3	M4
External checks				
Check fuel lines for leaks	●	●	●	●
Check headlight levelling			●	●
Checks underneath the vehicle				
Clean rear axle oil breather	●	●	●	●
Clean drive axle oil breather	●	●	●	●
Clean transmission assembly oil breather	●	●	●	●
Check condition of steering gaiters and sleeves	●	●	●	●
Check steering linkages and steering column	●	●	●	●
Check hydraulic brake lines for leaks	●	●	●	●
Inspection of brake disks, pads and callipers	●	●	●	●
Check tightness of engine cooling system	●	●	●	●
Mechanical units fluid seal check	●	●	●	●
Check steering box fastening			●	●
Check universal joints and propeller shaft fixing			●	●

SCHEDULED MAINTENANCE

TABLE OF MAINTENANCE OPERATIONS				
	M1	M2	M3	M4
Checks in cab				
Check parking brake travel	●	●	●	●
Fault diagnosis				
Engine EDC system check-up with E.A.SY.			●	●
Miscellaneous				
Hood opening and closing, removal and refitting engine guards	●	●	●	●
Manoeuvring operations (2)	●	●	●	●
Functional road test	●	●	●	●

(2) Vehicle and equipment handling activities in workshop.

Non-programmed/Time operations

If possible, at the same time as a maintenance service

EPI Every 200,000 km or 4,000 hours (heavy duty use)
Every 400,000 km or 8,000 hours (road use)

Replace timing primary chain, secondary chain, and chain tensioner

Replacement of timing gears with the chains removed

Replacement of exhaust system catalytic converter (vehicles equipped with a particulate filter)

T1 Every year (at the start of spring)

Remove, check and refit pollen filter

T2 Every year (at the start of winter)

Check coolant density

Change supplementary heater fuel filter

SCHEDULED MAINTENANCE

T3 every two years

Change fluid and bleed hydraulic brake system

T4 Every three years

Change cartridge and clean air filter box ⁽¹⁾

Change engine coolant⁽²⁾

(1) Early clogging of the air filter is generally due to adverse environmental conditions. For this reason it needs to be replaced when signalled by the sensor irrespective of the guidelines that anyhow have to be observed if there are no specific instructions otherwise.

(2) Parafllu I I has to be diluted 50% with water, whereas Parafllu FE is already diluted 50% with water.

SCHEDULED MAINTENANCE

OVERALL MAINTENANCE AND LUBRICATION PLAN	
Model	Chassis
License plate	Registration date
Surname	
Name	
Address	
Town	Telephone

The pages that follow give a summary description of the maintenance operations to be carried out at predefined kilometric readings, as fixed by the Maintenance Department, and, in conjunction with the latter, the specific fields in which the appropriate stamp is to be applied - validating the operations.

SCHEDULED MAINTENANCE

Overall maintenance and lubrication plan

KM X 1000	HOURS	A	B	MILEAGE (KM) DONE SERVICE VOUCHER	DATE DAY/MONTH/YEAR	VALIDATION PERFORMANCE SERVICES
20	400	M1	-	 /..... /.....	
40	800	M2	M1	 /..... /.....	
60	1200	M3	-	 /..... /.....	
80	1600	M2	M2	 /..... /.....	
100	2000	M1	-	 /..... /.....	
120	2400	M4	M3	 /..... /.....	
140	2800	M1	-	 /..... /.....	
160	3200	M2	M2	 /..... /.....	

A: Heavy duty use (mainly off-road)

B: Road use

SCHEDULED MAINTENANCE

KM X 1000	HOURS	A	B	MILEAGE (KM) DONE SERVICE VOUCHER	DATE DAY/MONTH/YEAR	VALIDATION PERFORMANCE SERVICES
180	3600	M3	-	 /..... /.....	
200	4000	M2	M1	 /..... /.....	
220	4400	M1	-	 /..... /.....	
240	4800	M4	M4	 /..... /.....	
260	5200	M1	-	 /..... /.....	
280	5600	M2	M1	 /..... /.....	
300	6000	M3	-	 /..... /.....	
320	6400	M2	M2	 /..... /.....	

SCHEDULED MAINTENANCE

KM X 1000	HOURS	A	B	MILEAGE (KM) DONE SERVICE VOUCHER	DATE DAY/MONTH/YEAR	VALIDATION PERFORMANCE SERVICES
340	6800	M1	-	 /..... /.....	
360	7200	M4	M3	 /..... /.....	
380	7600	M1	-	 /..... /.....	
400	8000	M2	M2	 /..... /.....	
420	8400	M3	-	 /..... /.....	
440	8800	M2	M1	 /..... /.....	
460	9200	M1	-	 /..... /.....	
480	9600	M4	M4	 /..... /.....	
500	10000	M1	-	 /..... /.....	

SCHEDULED MAINTENANCE

KM X 1000	HOURS	A	B	MILEAGE (KM) DONE SERVICE VOUCHER	DATE DAY/MONTH/YEAR	VALIDATION PERFORMANCE SERVICES
520	10400	M2	M1	 /..... /.....	
540	10800	M3	-	 /..... /.....	
560	11200	M2	M2	 /..... /.....	
580	11600	M1	-	 /..... /.....	
600	12000	M4	M3	 /..... /.....	
620	12400	M1	-	 /..... /.....	
640	12800	M2	M2	 /..... /.....	
660	13200	M3	-	 /..... /.....	
680	13600	M2	M1	 /..... /.....	

TECHNICAL CHARACTERISTICS

Technical characteristics

Identification data	251
Models	253
Engine	254
Gearbox	255
Front axle	255
Rear axle	255
Steering system	255
Suspension	255
Braking system	256
Electrical system	256
Tyre pressures	259
Refuelling	260
Lubricants international designation	263

250

TECHNICAL CHARACTERISTICS

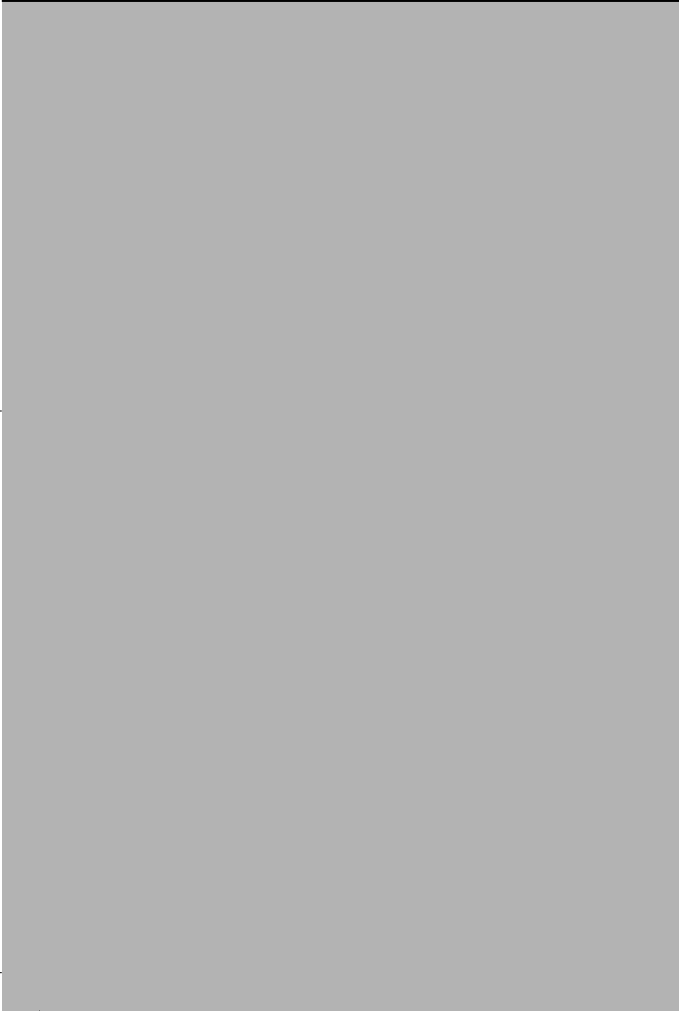

TECHNICAL CHARACTERISTICS

Vehicle identification data

The engine type and number, chassis type and number and the Manufacturer's name plate are your vehicle's identification data

Manufacturer's name plate

Allows identification of the vehicle as per EU Directive.

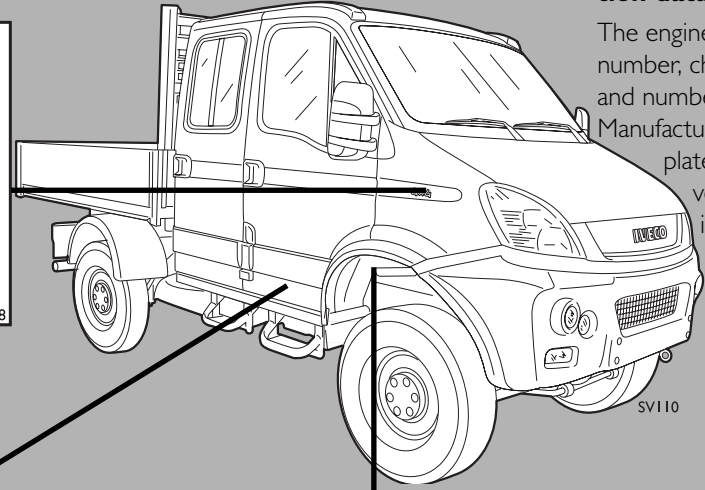
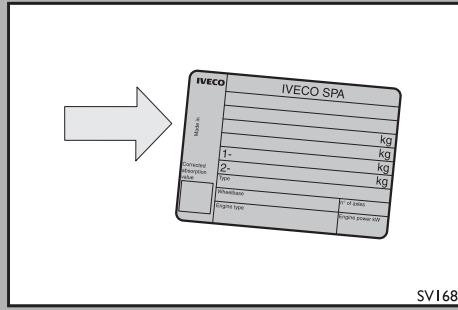

Chassis

Stamping (front of chassis right rail).

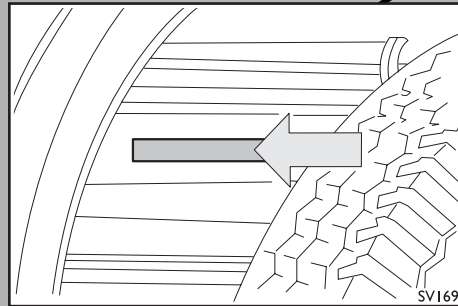

Engine

Stamped on the cylinder block/crankcase, right side.

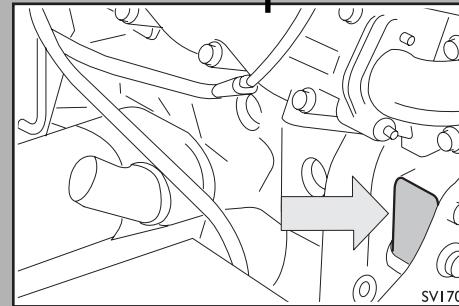

TECHNICAL CHARACTERISTICS

IVECO 12) Made in Corrected absorption value 11)	IVECO SPA	
	1)	
	2)	
	3) kg	
	4) kg	
	1-	5) kg
	2-	6) kg
	Type 7)	
	Wheelbase 8)	n° of axles 13)
	Engine type 9)	Engine power kW 10)

SV171

Vehicle identification plate

1. Type-approval number.
2. Chassis number.
3. PTT-Total weight.
4. MTC-Combined total weight.
5. Max. permissible weight on front axle.
6. Max. permissible weight on rear axle.
7. Specific type identification.
8. Wheelbase in mm.
9. Engine type.
10. Engine power.
11. Permissible smoke grade value.
12. Place of production.
13. Number of axles.

TECHNICAL CHARACTERISTICS

MODELS

MODEL	VERSION	Engine	GEARBOX	FRONT AXLE	REAR AXLE
35S17 W	Cab	FIC (170 HP)	ZF 6 S400 O.D.	HS 6.07	HS 8.09
35S17-DW	Double Cab	FIC (170 HP)	ZF 6 S400 O.D.	HS 6.07	HS 8.09
35S17-CCR W	Reduced Scudato	FIC (170 HP)	ZF 6 S400 O.D.	HS 6.07	HS 8.09
35S17-CA W	Cut Away	FIC (170 HP)	ZF 6 S400 O.D.	HS 6.07	HS 8.09
55S17 W	Cab	FIC (170 HP)	ZF 6 S400 O.D.	HS 6.07	HS 8.09
55S17 D W	Double Cab	FIC (170 HP)	ZF 6 S400 O.D.	HS 6.07	HS 8.09
55S17 CCR W	Reduced Scudato	FIC (170 HP)	ZF 6 S400 O.D.	HS 6.07	HS 8.09
55S17 CA W	Cut Away	FIC (170 HP)	ZF 6 S400 O.D.	HS 6.07	HS 8.09

35S17W model not available in
Australia

TECHNICAL CHARACTERISTICS**Engine**

ENGINE TYPE		FIC
Number of cylinders	4	
Bore	mm	95.8
Stroke	mm	104
Displacement	cm ³	2999
Max. useful power	kW (CV)	129 (170)
At speed of approx	rpm	3500
Maximum torque	Nm	400
At speed of approx	rpm	1250

TECHNICAL CHARACTERISTICS**Gearbox**

Manual, with synchromesh gears.

Type 6S 400 OD with six forward speeds (sixth Overdrive) and one reverse.

Front axle

Single reduction.

Rear axle

Single reduction.

Steering system

Standard hydraulic power steering on all versions.

Reduction gear

SCAM type reduction unit (low and half gear - third differential).

Front suspension

Mechanical. With parabolic leaf springs and double-acting hydraulic shock absorbers.

Rear suspension

Mechanical. With parabolic leaf springs and double-acting hydraulic shock absorbers.

TECHNICAL CHARACTERISTICS**Braking system**

Hydraulic with vacuum brake. Front disc brakes, rear drum brakes. Manual parking brake acting on rear wheels. ABS standard of models 55S, on request for models 35S.

Electrical system

Battery: 12V - 100Ah -760A

Starter motor: 2.2 kW

Alternator: 1260W, 14V, 90A.

140a alternator std in Australia

180a alternator available as option

TECHNICAL CHARACTERISTICS

LAMPS	TYPE	POWER WATTS
Headlights and low beam	high beam H1	55
	low beam H7	55
FOG LAMPS	halogen H1	55
Front position lights	tube W5W	5
Front indicators	spherical PY21W	21
Side indicators	spherical	16
Rear side lights	spherical	5
Rear direction indicators	spherical	21
Stop lights	spherical	21
License plate light	spherical	5
REVERSING LIGHT	spherical	21
REAR FOG LAMP	spherical	21
Interior lights cylindrical	tube W5W 10/15	5

High and low beam lights type longlife.

Note: When replacing lamps, new ones must have the same characteristics as the ones being replaced.

TECHNICAL CHARACTERISTICS



With the vehicle in running order, these tables allow the correct working pressure for the tyres to be determined according to the type of tyre fitted and the weights acting on the front and rear axle.

The pressures indicated are for cold tyres and outside temperature of 20°C.

The maximum capacity of a tyre with a smaller load index is lower.

CAUTION!

Snow chains cannot be used with front off-road tyres (255/100 R16).

<

TECHNICAL CHARACTERISTICS

Tyre pressures

Weight on front/rear axle [kg]

ROAD TYRES																				
TYRE TYPE	LOAD INDEX	INFLATION PRESSURE [ATM]																		
		4.00	4.25	4.50	4.75	5.00	5.25	5.50	5.75	6.00	6.25	6.50	6.75	7.00	7.25	7.50	7.75	8.00	8.25	8.50
9.5 R17.5	129/127	2270	2390	2510	2630	2750	2860	2980	3100	3220	3340	3460	3580	3700	-	-	-	-	-	-
9.5 R17.5	143/141	-	-	-	-	-	-	3680	3830	3980	4120	4270	4420	4570	4710	4680	5010	5160	5300	5450

OFF-ROAD TYRES							
TYRE TYPE	LOAD INDEX	INFLATION PRESSURE [ATM]					
		3.00	3.50	3.75	4.00	4.25	4.50
255/100 R16	126/124	2430	2750	2910	3080	3240	3400

TECHNICAL CHARACTERISTICS



Fuel

Use only diesel oil in accordance with EN 590 standard, which is normally commercially available.

Fuel additives are **not recommended**. The use of additives can limit the warranty services offered for the vehicle.

Refuelling from drums or jerry cans can contaminate the diesel oil, with possible feed system problems; in such cases it is necessary to carry out adequate filtering or decanting of any impurities present.

Low temperature diesel fuel

At low temperatures the fluidity of the diesel fuel may become insufficient due to separation of the paraffin, with clogging of the filters.

Standard EN 590 specifies different classes of diesel fuel for use at low ambient temperatures.

It is entirely up to the oil companies to comply with the standards according to the climatic conditions (seasons and geographical location of the countries).

Refuelling



Additives for lubricants are not necessary.

- The use of special additives may limit the right to warranty. The consumable materials are harmful for the health.
- In case of swallowing, see a doctor immediately. Keep consumable materials out of the reach of children.
- Dispose of consumable materials and parts in contact with them (e.g. filters) in accordance with the law.
- The Service Network workshops are equipped for this purpose.

TECHNICAL CHARACTERISTICS

	ORIGINAL PRODUCTS	LITRES	KG
Engine sump	(MIN level)	4.3	3.78
	(MAX level)	Urania Daily ⁽¹⁾	6.6
Oil filter		1	0.88
Gearbox 6 S400 O.D.	Tutela Truck Gearlite	2.2	1.98
Rear axle HS 8.09 and HS 6.07	Tutela W140/M-DA	3.2	2.9
	Tutela W90/M-DA ⁽²⁾		
Oil for A.P.U. electrohydraulic unit	Tutela GI/R	0.7	0.63
Transmission assembly	Tutela W90/M - DA	3	2.7

(1) IVECO recommends using *Urania Daily* for better fuel economy and to improve the efficiency of the particulate filter (on vehicles fitted with it) even in harsh conditions.

New vehicles are already equipped by IVECO with this type of lubricant. Suitable also for cold climates (minimum temperature of -30°)

(2) Specific for cold climates.

TECHNICAL CHARACTERISTICS

	ORIGINAL PRODUCTS	LITRES	KG
Power steering	Tutela GI/A	1.4	1.3
Brake circuit	Tutela TRUCK DOT SPECIAL	1.1	1
windscreen washer	Tutela Professional SC 35	5	4.5
Fuel tank	Diesel	90	-
Cooling system	Paraflu II ⁽¹⁾ Paraflu FE ⁽²⁾	9	8.1

(1) 100% Paraflu to dilute 50% with water.

(2) Paraflu already diluted 50% with water.

TECHNICAL CHARACTERISTICS

LUBRICANTS INTERNATIONAL DESIGNATION	ORIGINAL PRODUCTS
<p>Engine oil Meets specifications: • Synthetic based ACEA C2 Qualification IVECO Standard 18-1811</p>	<p>SAE 5W30 Urania Daily ⁽¹⁾</p>
<p>Oil for differential and wheel hubs Meets specifications: • API GL5 mineral base Qualification IVECO Standard 18-1805</p>	<p>SAE 80W90 SAE 85W140 Tutela W90/M-DA ⁽²⁾ Tutela W140/M-DA</p>
<p>Transmission assembly oil Meets specifications: • API GL5 mineral base Qualification IVECO Standard 18-1805</p>	<p>SAE 80W90 Tutela W90/M - DA</p>
<p>Oil for mechanical gearboxes Contains non-EP anti-wear additives Meets specifications: • API GL4 Qualification IVECO Standard 18-1807</p>	<p>SAE 75W80 Tutela Truck Gearlite</p>
<p>Oil for power steering and hydrostatic transmissions Meets specifications: • ATF DEXRON II D Qualification IVECO Standard 18-1807</p>	<p>Tutela GI/A</p>

TECHNICAL CHARACTERISTICS

LUBRICANTS INTERNATIONAL DESIGNINATION	ORIGINAL PRODUCTS
Grease for general greasing Lithium soap based; N.L.G.I. grade. n.2 Certification IVECO STANDARD 18-1810	Tutela MR 2
Fluid for hydraulic brakes and clutch control Complies with standards: <ul style="list-style-type: none"> • N.H.T.S.A. N.116 DOT 4 • ISO 4925 • Standard SAE J 1704 Qualification IVECO Standard 18-1820	Tutela TRUCK DOT SPECIAL
Windscreen wiper liquid Mixture of alcohols, water and surface active agents CUNA NC 956-II Qualification IVECO Standard 18-1802	Tutela Professional SC 35
Specific grease for bearings and wheel hubs Lithium soap based; N.L.G.I. grade. n.3 Certification IVECO STANDARD 18-1810	Tutela MR 3
Concentrated protective fluid for radiators Glycol-based, containing corrosion inhibitors, conforming to norm: Paraflu I I (3) Qualification IVECO Standard 18-1830	Paraflu I I ⁽³⁾ Paraflu FE ⁽⁴⁾
Oil for electrohydraulic unit Qualification IVECO Standard 18-1807 Class A.P.U.	Tutela GI/R
Refrigerant fluid for air conditioners Qualification IVECO Standard 18-1835	R134a



- > For vehicles with particulate filter; when changing the oil the regeneration counter must be reset at the IVECO Service Network. Otherwise regeneration could become blocked with subsequent clogging of the particulate filter, as well as reduced engine performance. Excessive filter clogging **would permanently damage it.**

Important: IVECO guarantees optimum engine performance with the use of original lubricants. If non-original products are used, lubricants with minimum ACEA performance indicated in the table are acceptable. Using products with inferior characteristics to the ACEA specifications could cause damage to the engine, and this damage is not covered by warranty.

- (1) *IVECO recommends using Urania Daily for better fuel economy and to improve the efficiency of the particulate filter (on vehicles fitted with it) even in harsh conditions. New vehicles are already equipped by IVECO with this type of lubricant. Suited for cold climates too (minimum temperature down to -30°C).*
- (2) *Specific for cold climates.*
- (3) *100% Parafllu to dilute 50% with water.*
- (4) *Parafllu already diluted 50% with water.*

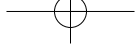

TECHNICAL CHARACTERISTICS

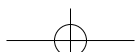
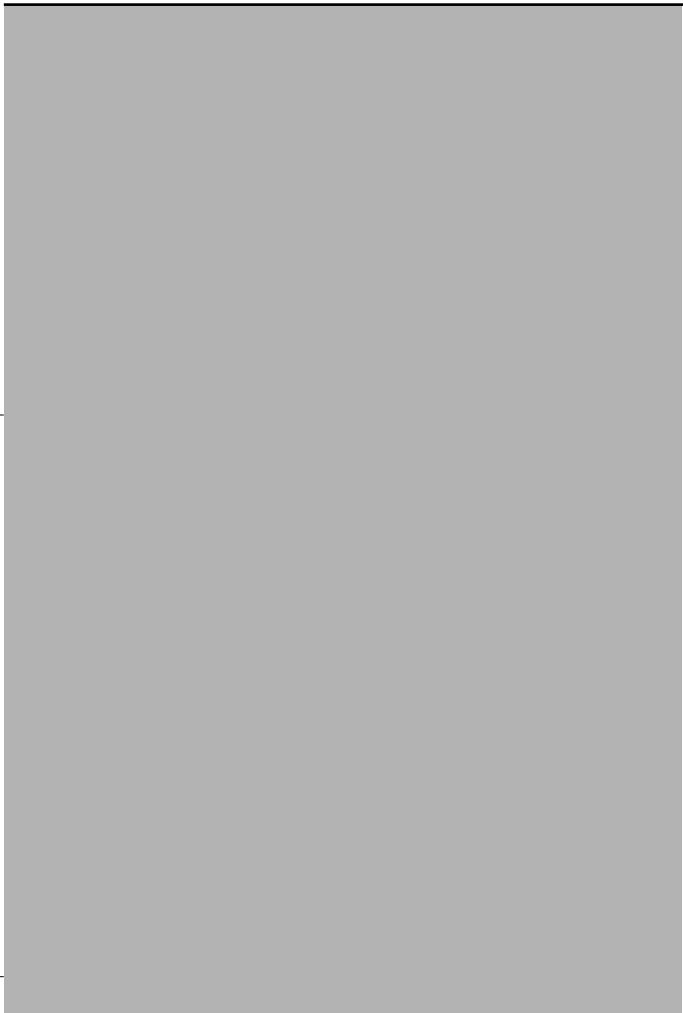

Plates

On some components of your vehicle, or near them, there are specific plates that are coloured to draw the user's attention to the precautions to observe for the component in question.

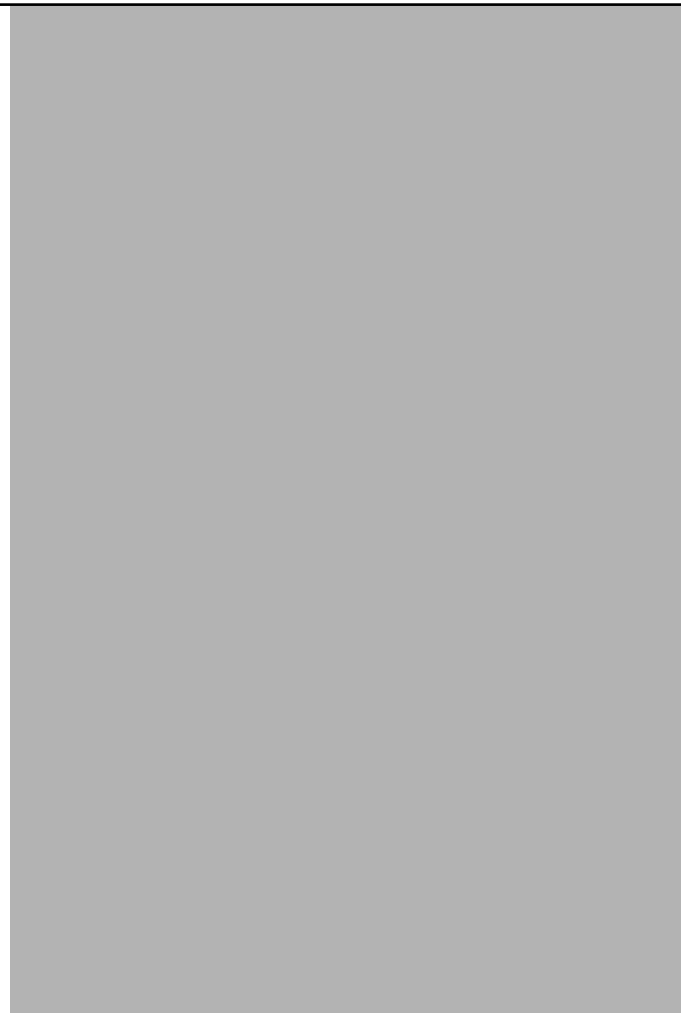

PLATES



Danger symbols

1. Battery-Corrosive liquid.
2. Battery-Explosion.
3. Expansion tank - Do not remove the cap with the coolant boiling.
4. Belts and pulleys - Moving parts: keep parts of the body or garments away.
5. Air conditioner pipes - Do not open. High pressure gas.

Prohibition symbols

6. Battery - Keep naked flames away.
7. Battery - Keep children away.
8. Heat guards/belts/pulleys/fan - Do not install baby seats on the front passenger seat.
9. Passenger side airbag - Do not install child seats on the front passenger seat.

Warning symbols

10. Power steering - Do not exceed the max. fluid level in the reservoir. Use the specified fluid.
11. Brake circuit - Do not exceed the max. fluid level in the reservoir. Use the specified fluid.
12. Windscreen wipers - Use the specified liquid.
13. Engine - Use the specified lubricant.
14. Expansion tank - Use the specified liquid.

Obligation symbols

15. Battery - Protect eyes.
16. Battery/Jack - Refer to the Use and Maintenance handbook.

PLATES

IVECO		LUBRIFICANTI E LIQUIDI ORIGINALI ORIGINAL LUBRICANTS AND FLUIDS LUBRIFIANTS ET LIQUIDES ORIGINAUX LUBRIFICANTES Y LIQUIDOS ORIGINALES ORIGINAL SCHMERSTOFFE	PETRONAS LUBRICANTS
Olio Motore Engine Oil Huile Moteur Aceite del Motor Motorenöl	Urania Motor oil	Differenziali Differential Différentiels Diferenciales Differenzials	
Radiatore Radiator Radiateur Radiator Kühler	Parafly TM	Servosterzo Power Steering Direction assistée Dirección asistida Hydrosteering	TUTELA TRANSMISSIONE
Lavacrystal Windscreen Washer Lave-glace Laventristales Scheibenwaschanlage	TUTELA PROFESSIONAL	Gruppo elettro-idraulico ausiliario * Electrohydraulic auxiliary unit * Unité électrohydraulique auxiliaire * Zusätzliche elektrohydraulische Maßeinheit *	
Cambio Gearbox Boîte de Vitesses Cambio Getriebe	TUTELA TRANSMISSIONE TRUCK	Circuito Freni Brake System Circuit Freins Sistema de Mando Frenos Bremskreis	TUTELA LUBRIFICANTI
- Utilizzare i prodotti prescritti sul libretto di uso e manutenzione - Please refer to the products specified in the owner's manual - Utiliser les produits indiqués sur la notice d'entretien		- Use el producto aconsejado en el manual de uso y mantenimiento - Benutzen Sie die produkte die in der Betriebsanleitung vorgesehen sind	
	Circuito Freni Brake System Circuit Freins	Sistema de Mando Frenos Bremskreis	* Solo veicoli 4x4 * Nur 4wd Fahrzeuge * Just 4wd vehicles * Sólo vehículos 4x4



PERICOLO: Alta tensione
DANGER: High Voltage
AKTUNG: Hochspannung
DANGER: Haute Tension
PELIGRO: Voltaje alto

PERICOLO! Vedere libretto uso e manutenzione prima di ogni operazione all'interno del vano motore!

DANGER! See user manual before every operation in the hood!

AKTUNG! Lesen sie das Kunde Handbuck früher jede Operation in der Motorraum!

DANGER! Regardez le livret de usage avant de chaque opération dans le moteur vain!

PELIGRO! Ver manual de usuario y mantenimiento antes de cualquier intervención en vano motor!

Fluids table plate

Located inside the bonnet. Indicates original lubricants

High voltage danger plate

Located inside the bonnet. Indicates the presence of high voltage electrical components.



> **CAUTION!**

- Disconnect the battery cables before doing any work on the electrical system. Avoid any tampering with the electrical system. If this is necessary, contact the Service Network. Only use fuses of the specified amperage: risk of fire. Replace the fuses only after eliminating the cause of the problem. Changes or repairs to the electrical system carried out incorrectly without taking into account the technical characteristics of the system can cause operation anomalies with risk of fire.
- Never replace the maxi-fuses. If necessary, contact the Iveco Service Network.

Fuses

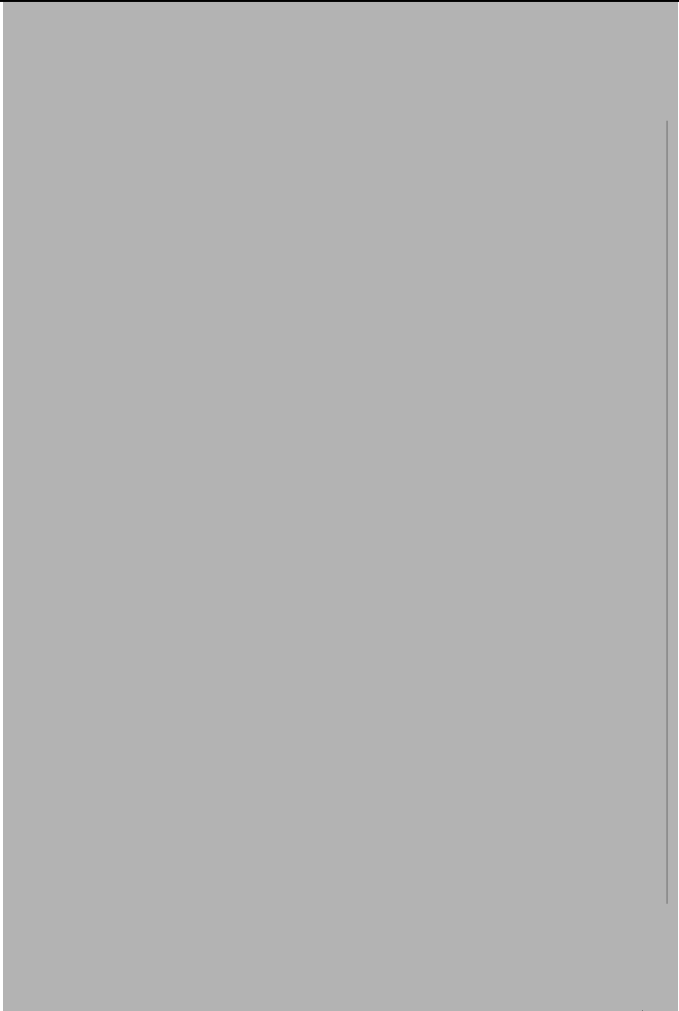

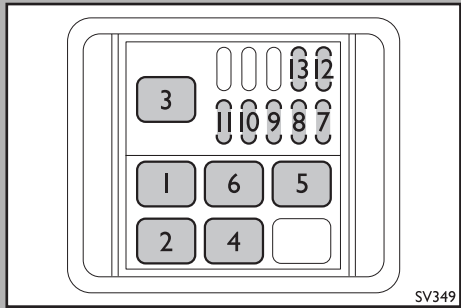

Differential lock management control unit

A control unit for management of the various differential locks and other vehicle services is located under the left seat.

N	FUNCTION	AMPERE RATING
1	A.P.U. diode container.	
2	A.P.U. diode container.	
3	A.P.U. relay.	12 V - 70 A
4	Hydraulic command logic control unit relay	12 V - 12/20 A
5	Siren relay	12 V - 12/20 A
6	ABS relay	12 V - 12/20 A
7	Front differential lock fuse	3 A
8	Middle differential lock fuse	3 A
9	Rear differential lock fuse	3 A
10	Reduction unit PTO fuse	3 A
11	Engine PTO fuse	3 A
12	Siren fuse	3 A
13	Hydraulic command logic control unit relay	3 A

FUSES**Fuse holder control unit and relay under the dashboard**

Located in a special compartment, closed by drawer held by 4 removable screws.

There is a plier next to the control unit to facilitate fuse removal.

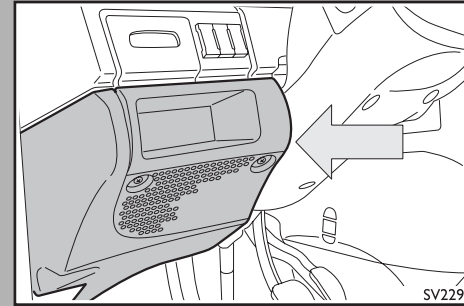

Fuse holder control unit and relay under dashboard

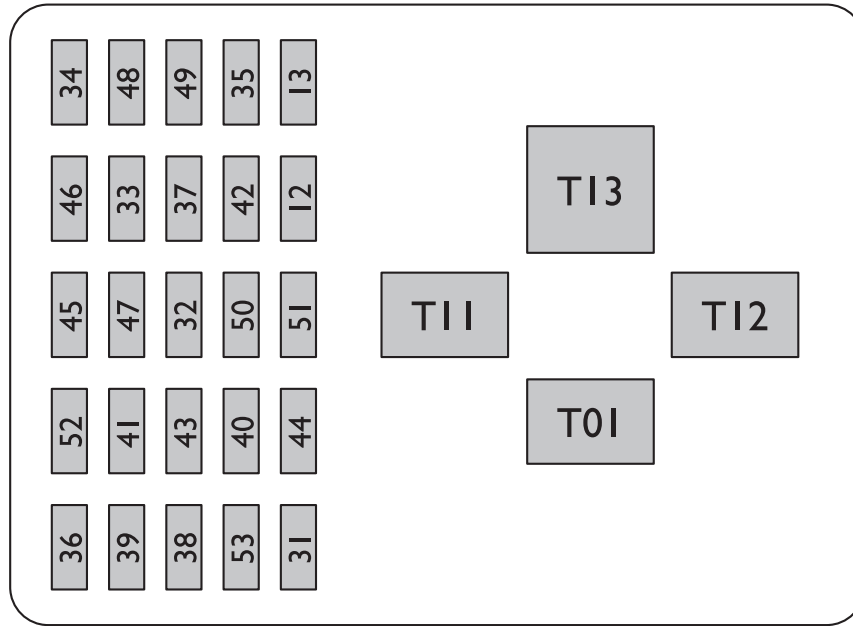

FUSES

FUSE	USE	AMPERE RATING
F 12	Right low-beam	7.5 A
F 13	Left low beam-headlight leveller	7.5 A
F 31	Relay T08-T17 in CVM and BC	3 A
F 32	available BB #1 pin 6 - Positive supply 15 A	-
F 33	Unit heater / Electric lighter	15 A
F 34	Power socket	20 A
F 35	ABS8/ASR8/ESP8	10 A
F 36	Central locking	20 A
F 37	Switch for brake lights and various loads under +15	5 A
F 38	Supply of internal relays of BC / Interior light units	10 A
F 39	Radio-chronotachograph	15 A
F 40	available	-
F 41	available	-
F 42	Reversing lights switch	5 A
F 43	Windscreen wipers	20 A
F 44	available	-
F 45	Power supply for power window switch (LP and LA) and rear vision mirror adjuster	3 A
F 46	available	-
F 47	Driver's power window	25 A
F 48	Passenger power window	25 A
F 49	Climate control ECU, radio, heated seats & BB #1 pin 11 Ign switched Supply limited to 5 A -15 A fuse	5 A
F 50	Airbags	5 A
F 51	Tachograph	5 A
F 52	AVAILABLE (+15 with exclusion of loads through T12)	-
F 53	Instrument panel, rear fog lamp	7.5 A
RELAYS	USE	AMPERE RATING
T 01	Right and left low beam headlights	-
T 11	Heated rear window	-
T 12	Windscreen wiper / washer	-
T 13	Power discharge by key	-

FUSES

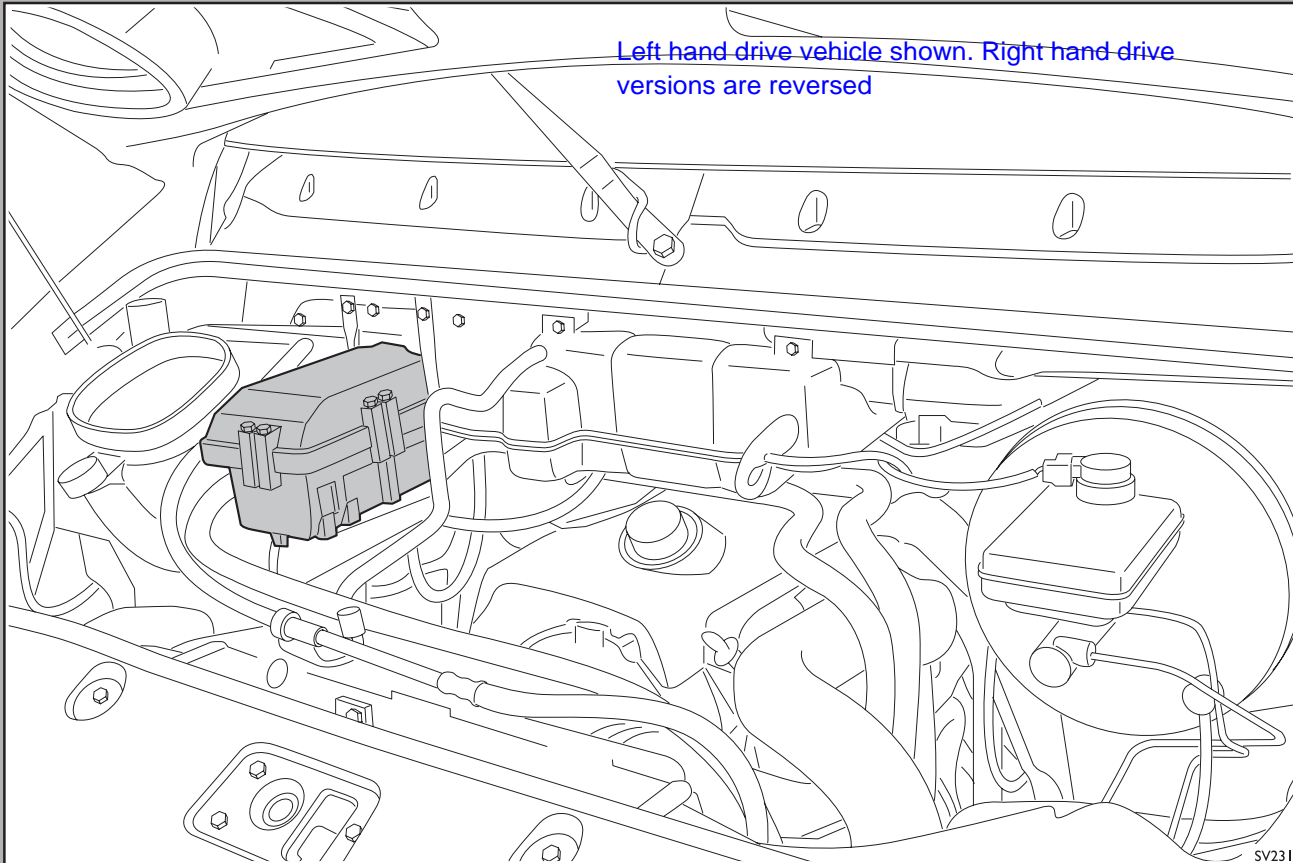
Engine compartment relay and fuse holder control unit

FUSES

Engine compartment relay and fuse holder control unit

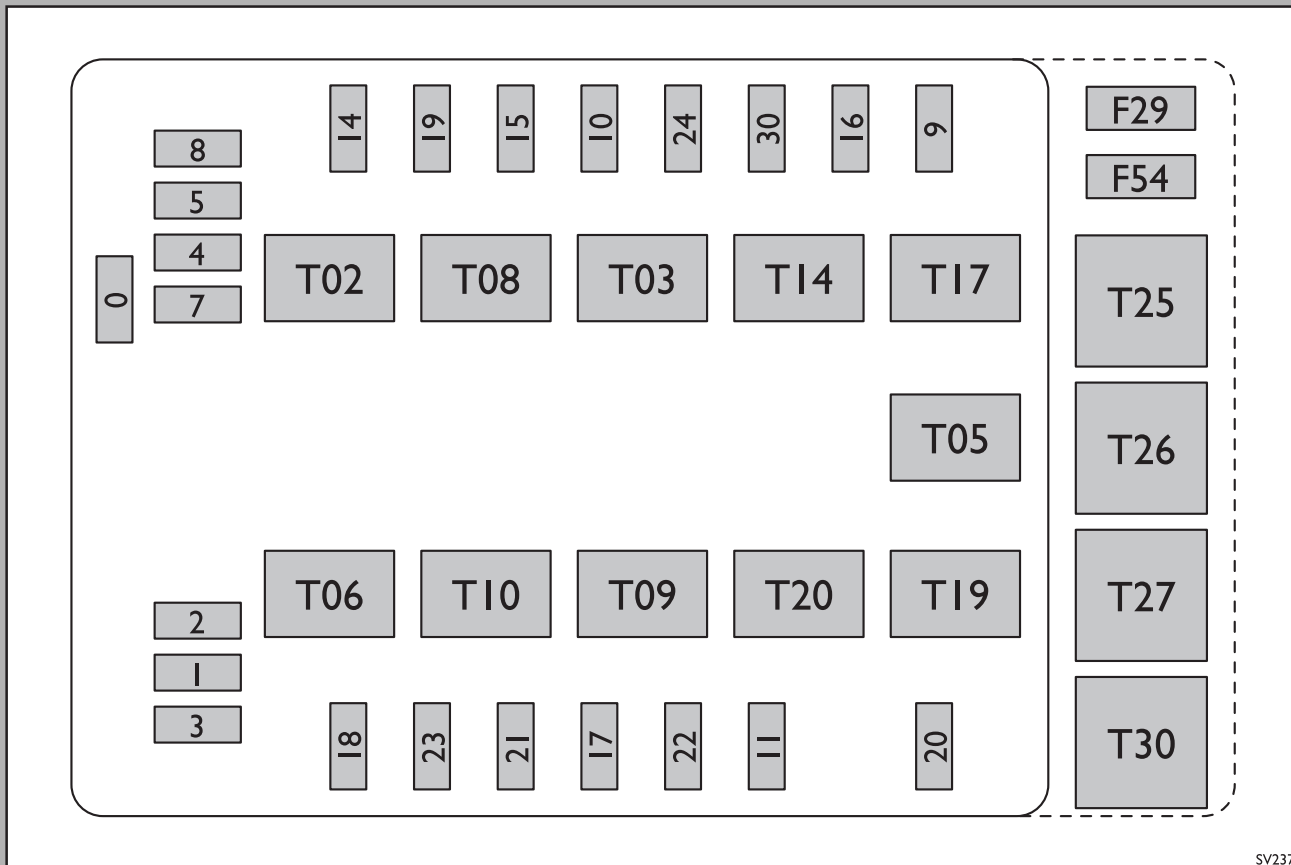

FUSES

FUSE	FUNCTION	AMPERE RATING
F 0	Glow plugs	60 A
F 1	ABS	30 A
F 2	ABS	30 A
F 3	available	20 A
F 4	available	30 A
F 5	Starter switch	30 A
F 6	available	20 A
F 7	Heated filter	20 A
F 8	Heater or climate control fans	40 A
F 9	Windscreen washer pump	20 A
F 10	Horn	7.5 A
F 11	EDC17 (secondary loads)	15 A
F 14	Right high beam	7.5 A
F 15	Left high beam	7.5 A
F 16	Trailer Socket Blow-by	5 A
F 17	EDC17 (primary loads)	10 A
F 18	available	10 A
F 19	Baruffaldi electromagnetic coupling	5 A
F 20	Fuel filter heater	25 A
F 21	Fuel pump	15 A
F 22	EDC17 (primary loads)	25 A
F 23	Heated mirrors and windscreen/B pole socket	15 A
F 24	PTO	15 A
F 30	Left and right fog lamp	15 A
in the framework outside the control unit		
F 26	available	-
F 29	available	-
F 54	available	-

FUSES

RELAY	FUNCTION
T 02	Left and right high beam
T 03	Horn
T 05	Baruffali coupling power supply from EDC17
T 06	Baruffali coupling power supply from EDC17
T 07	Heated filter
T 08	Heater or climate control fans
T 09	EDC17 (Main relay)
T 10	Fuel pump
T 14	Left and right fog lamp
T 17	Windscreen washer pump
T 19	Fuel filter heater
T 20	Diagnosis (power supply +15 forced)

in the framework outside the control unit

T 25	Windscreen wipers on / off
T 26	Windscreen wipers 1st / 2nd speed
T 27	Heating of heated rear view mirrors / heated windscreen
T 30	Available

FUSES

Optional fuse carrier box (engine compartment)

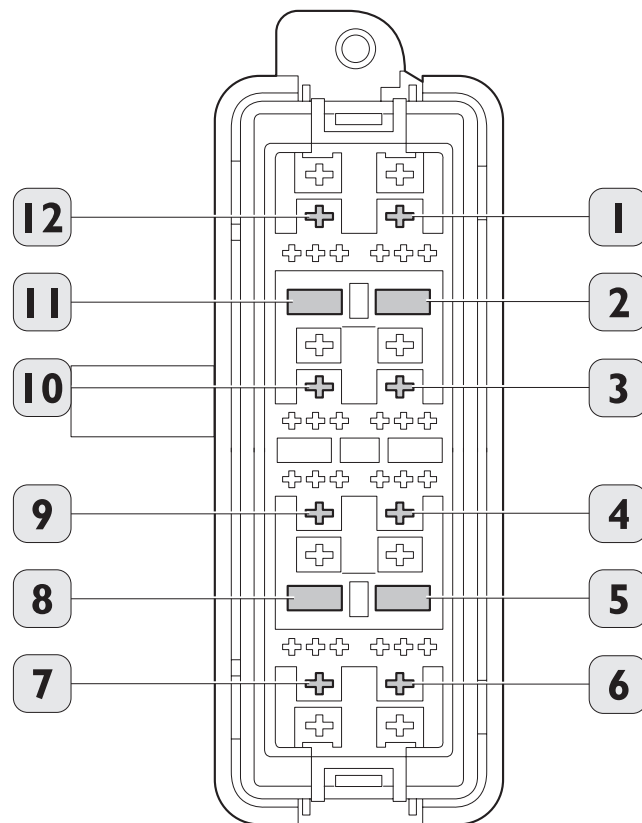

FUSES

REFERENCE	REFERENCE DRAWING	USE	AMPERE RATING
1	T4	Available	-
2	F55	Supplementary climate control unit fuse	30 A
3	T15	Heater unit	-
4	T22	Available	-
5	F25	Climate control unit (timer, control unit and heater)	30 A 10 A
6	T18	Available	-
7	T24	PTO enabling contactor	-
8	F28	Positive fuse for differential lock control unit	- 30 A
9	T23	Air conditioning compressor control contactor	-
10	T21	Remote control switch for signalling compressor on for EDC17	-
11	F27	Positive fuse for headlamp wiper	20 A
12	T16	Headlamp wiper contactor	-

FUSES

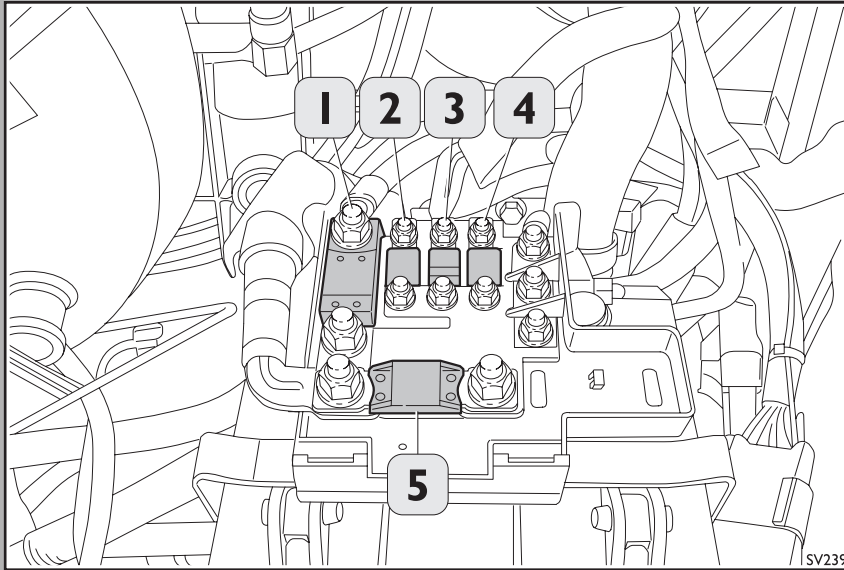

SV239

CBA power fuse control unit

Located next to battery positive pole.

REFERENCE	FUNCTION	AMPERE RATING
1	CVM power supply	150 A
2	Power supply 2 CPL	70 A
3	Fuel supply OPTIONAL BOX	50 A
4		70 A
5	Power supply 1 CPL	500 A

Important

Reference to the body builders manual must be made when introducing any optional electrical components or connections to the CBA unit

Alphabetical index

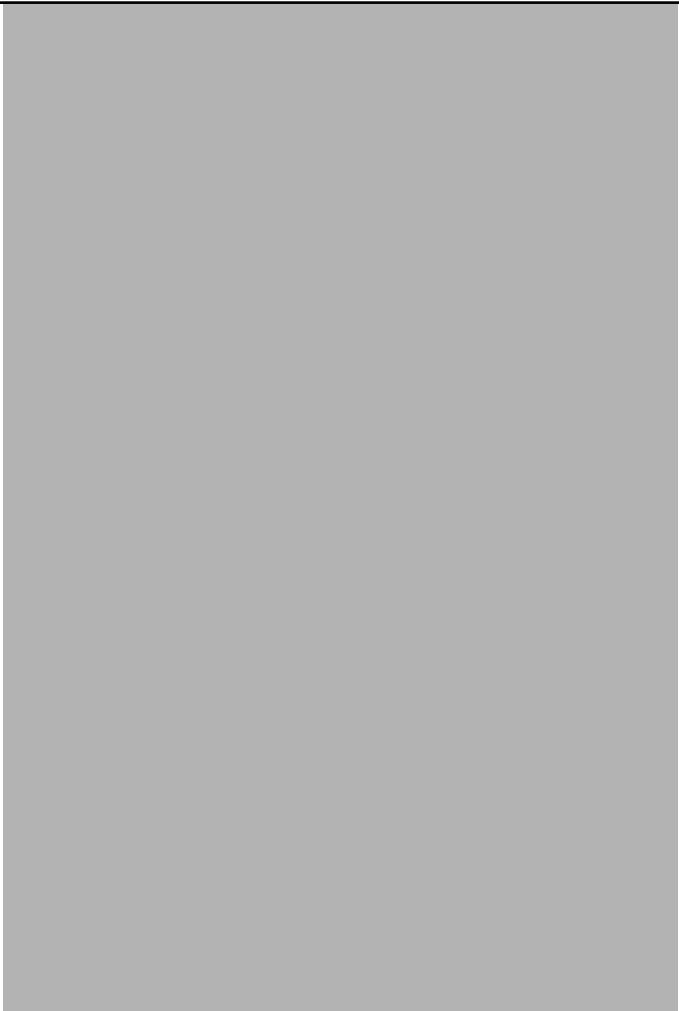

ALPHABETICAL INDEX

A

ABS	176
Accessories fitted by the user	150
Air bag	124
Alphabetical index	283

B

Battery	208
Before each trip	221
Braking system	256

C

Central dashboard	114
Central locking	164
Centralised locking + electronic alarm	165
Changing gear	172
Changing wheels	199
Checks to be carried by the user	217
COMFORT VERSION display	52
COMFORT VERSION instrument panel	41
COMFORT VERSION menu keypad	48
COMFORT VERSION menu layout	56
Controls and devices	117

ALPHABETICAL INDEX

D

Differential lock	174
Display messages - COMFORT VERSION	55
Doors	7
DPF (Diesel Particulate Filter)	112

E

Economical, environmentally-friendly driving	190
ECU's	201
EDC indicator light (fault diagnosis)	163
Electrical system	256
Engine	254
Engine compartment opening	218
Every week	226

F

Front axle	255
Fuses	271

G

Gearbox	255
---------	-----

H

Headlight levelling	140
Heating and ventilation	141

ALPHABETICAL INDEX

I

Identification data	251
Immobilizer	153
Independent supplementary heater	145
Interior equipment	138

K

Key switch positions	156
----------------------	-----

L

Lubricants international designation	263
--------------------------------------	-----

M

Maintenance services schedule	235
Maintenance stops by hours	238
Maintenance stops by kilometres	237
MODELS	253
Multi-function steering wheel levers	132

O

Odometer indication display - STANDARD VERSION	24
Off-road driving conditions	189
On board equipment	193
Overall maintenance and lubrication plan	244

ALPHABETICAL INDEX

P	
Plates	267
Power take-off	182
Power windows	130
Q	
Quick intervention	197
Quick troubleshooting guide	214
R	
Rear axle	255
Rear vision mirrors	128
Reduction unit - Transfer gear	173
Refuelling	260
Replacing lamps	200
S	
Safe driving	183
Scheduled maintenance	233
Scheduled maintenance function display - COMFORT VERSION	53
Scheduled maintenance function display - STANDARD VERSION	21
Scheduled maintenance philosophy	234
Seat belts	121
Seat belts unfastened function display - COMFORT VERSION	54
Seat belts unfastened function display - STANDARD VERSION	23

Seats	118
Service brake - parking brake	170
Spare wheel	198
speed programmer (Cruise Control)	178
STANDARD VERSION display	20
STANDARD VERSION instrument panel	9
STANDARD VERSION menu keypad	16
STANDARD VERSION menu layout	25
Starting and driving	151
Starting the engine	159
Starting the engine at low temperature	162
Steering system	255
Suspension	255

T

Table of maintenance operations	239
Technical characteristics	249
The driver's position	5
Tow hook	140
Towing the vehicle	213
Tyre pressures	259

ALPHABETICAL INDEX

v

Vehicle care	230
Vehicle keys	152

w

Windscreen and headlamp washer fluid reservoir	137
--	-----

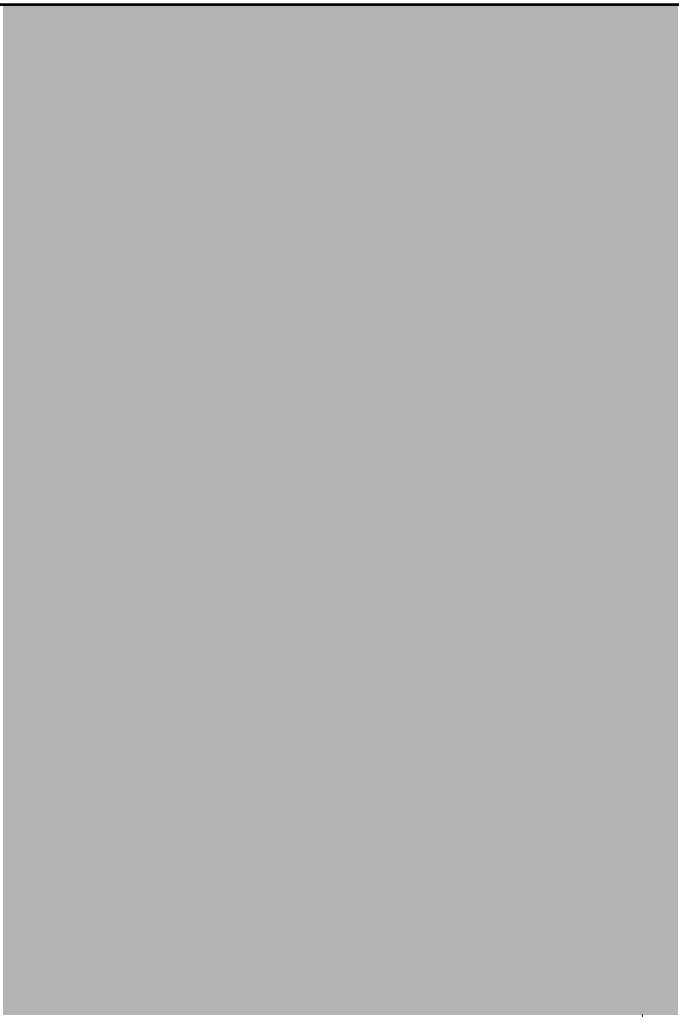



ORIGINAL PRODUCTS FOR IVECO.